

In-depth Technical Guide: Physical and Chemical Stability of Infigratinib-d3

Author: BenchChem Technical Support Team. **Date:** April 2026

Compound of Interest

Compound Name: *Infigratinib-d3*

Cat. No.: *B12377363*

[Get Quote](#)

For Researchers, Scientists, and Drug Development Professionals

Disclaimer: This document outlines a comprehensive technical framework for the evaluation of the physical and chemical stability of **Infigratinib-d3**. Publicly available, specific experimental stability data for this deuterated analog is limited. The methodologies and pathways described are based on the known characteristics of the non-deuterated parent compound, Infigratinib, and established pharmaceutical stability testing principles as mandated by regulatory bodies.

Introduction to Infigratinib and its Deuterated Analog

Infigratinib is a potent, orally bioavailable, ATP-competitive kinase inhibitor that selectively targets the fibroblast growth factor receptor (FGFR) family, with high affinity for FGFR1, FGFR2, and FGFR3.[1][2][3][4] Dysregulation of the FGFR signaling pathway is a known driver in various malignancies; consequently, Infigratinib was developed as a targeted therapy for cancers harboring FGFR genetic alterations, most notably for previously treated, unresectable locally advanced or metastatic cholangiocarcinoma with an FGFR2 fusion or other rearrangement.[1][2][4][5][6] **Infigratinib-d3**, a deuterated version of the molecule, serves as a

critical internal standard for bioanalytical studies, enabling precise quantification in complex biological matrices.

Physicochemical Properties

The fundamental physicochemical properties of Infigratinib provide a baseline for understanding the expected characteristics of its deuterated analog.

Property	Description
Chemical Name	3-(2,6-dichloro-3,5-dimethoxyphenyl)-1-(6-{{4-(4-ethylpiperazin-1-yl)phenyl}}amino}pyrimidin-4-yl)-1-methylurea[2]
Molecular Formula	Infigratinib: C ₂₆ H ₃₁ Cl ₂ N ₇ O ₃ Infigratinib-d3: C ₂₆ H ₂₈ D ₃ Cl ₂ N ₇ O ₃ [7]
Molecular Weight	Infigratinib: 560.47 g/mol [2] Infigratinib-d3: 563.49 g/mol [7]
Appearance	The phosphate salt of Infigratinib is a white to off-white, non-hygroscopic powder.[8]
Melting Point	190-198°C (Infigratinib phosphate)[8]
Solubility	Infigratinib-d3 is soluble in DMSO, requiring ultrasonic and warming for complete dissolution. [7] Infigratinib phosphate is also soluble in DMSO.[9]

Recommended Storage Conditions for Infigratinib-d3

Vendor-supplied data provides the following general storage guidelines for **Infigratinib-d3**.

Form	Storage Temperature	Recommended Duration
Powder	-20°C	3 years
4°C	2 years	
In Solvent	-80°C	6 months
-20°C	1 month	

Table data sourced from a commercial product data sheet.[\[7\]](#)

Mechanism of Action and Signaling Pathway

Infigratinib exerts its therapeutic effect by inhibiting the FGFR signaling cascade. The binding of fibroblast growth factors (FGF) to their receptors (FGFRs) induces receptor dimerization and subsequent autophosphorylation of the intracellular kinase domains.[\[10\]](#) This phosphorylation event creates docking sites for adaptor proteins, such as FRS2, which in turn activate critical downstream pathways, including the Ras-MAPK and PI3K-AKT signaling axes, promoting cell proliferation, survival, and angiogenesis.[\[1\]\[10\]](#) Infigratinib functions by competitively binding to the ATP pocket of the FGFR kinase domain, thereby blocking autophosphorylation and abrogating downstream signaling.[\[1\]\[5\]](#)

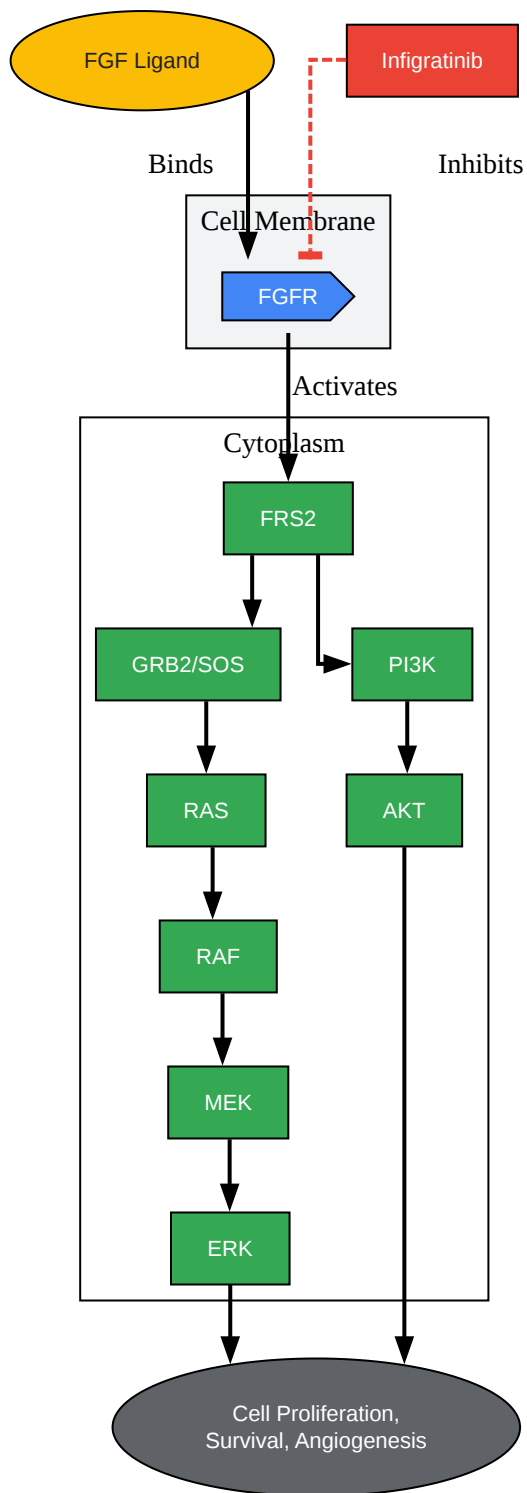

[Click to download full resolution via product page](#)

Caption: Infigratinib blocks the activation of downstream signaling pathways by inhibiting FGFR.

Experimental Protocols for Stability Assessment

A robust stability assessment of **Infigratinib-d3** requires a multi-faceted approach, beginning with forced degradation studies to understand its intrinsic stability and culminating in long-term studies under various environmental conditions.

Forced Degradation (Stress Testing)

Forced degradation studies are performed to deliberately degrade the drug substance under conditions more severe than accelerated stability testing.^{[11][12]} These studies are crucial for developing and validating a stability-indicating analytical method, identifying potential degradation products, and elucidating degradation pathways.^{[13][14]} The typical target for degradation is between 5-20% to ensure that the analytical method is challenged without generating secondary or tertiary degradation products that may not be relevant under normal storage conditions.^[13]

The workflow for stress testing involves exposing the drug substance to various conditions and analyzing the resulting material with a high-resolution analytical technique.

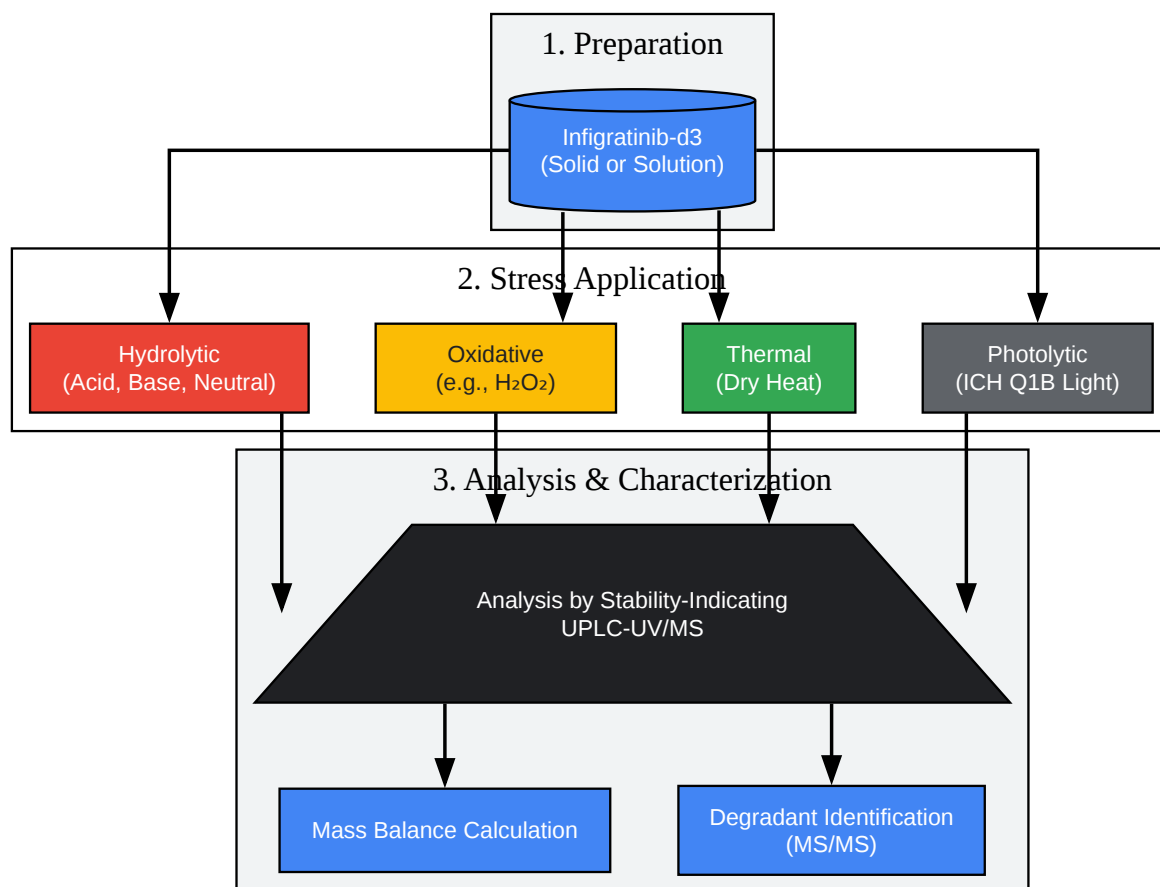

[Click to download full resolution via product page](#)

Caption: A systematic workflow for conducting forced degradation studies on a drug substance.

- Hydrolytic Degradation:

- Protocol: Prepare solutions of **Infigratinib-d3** in acidic (0.1 M - 1.0 M HCl), basic (0.1 M - 1.0 M NaOH), and neutral (water) conditions.[15]
- Conditions: Samples are typically maintained at room temperature or heated (e.g., 60°C) to accelerate degradation over a period of up to seven days.[15]
- Analysis: At predetermined intervals, aliquots are withdrawn, neutralized if necessary, and analyzed by a validated stability-indicating UPLC-UV/MS method.

- Oxidative Degradation:
 - Protocol: Dissolve **Infigratinib-d3** in a suitable solvent and treat with an oxidizing agent, such as 3% hydrogen peroxide.
 - Conditions: The reaction is typically carried out at room temperature, protected from light.
 - Analysis: Samples are analyzed at various time points to monitor the formation of oxidative degradants.
- Thermal Degradation:
 - Protocol: The solid drug substance is exposed to high temperatures (e.g., 80°C) in a controlled oven. The study can also be performed on the drug substance in solution.
 - Analysis: Samples are collected at specified times and analyzed to assess thermal lability.

Photostability Testing

Photostability testing is a mandatory part of stability assessment and is conducted according to the International Council for Harmonisation (ICH) Q1B guideline.^{[16][17][18]} Its purpose is to evaluate whether light exposure leads to unacceptable changes in the drug substance.

- Sample Exposure: A sample of the solid **Infigratinib-d3** and a solution in a photochemically inert solvent are exposed to a light source. A parallel set of samples, protected from light by wrapping in aluminum foil (dark controls), is stored under the same temperature and humidity conditions to isolate light-induced effects from thermal effects.^{[17][19]}
- Light Source: The samples are exposed to a minimum of 1.2 million lux hours of visible light and 200 watt-hours per square meter of near-ultraviolet (UV-A) light.
- Analysis: Following exposure, the samples are assayed and analyzed for impurities. Any significant increase in degradation products compared to the dark control indicates photosensitivity. Physical properties, such as appearance and color, are also evaluated.

Data Presentation: Summary of Expected Stability Profile

While specific experimental data for **Infigratinib-d3** is not available, the following table provides a template for summarizing the results from the described stability studies.

Stress Condition	Parameters	Expected Outcome / Potential Degradation Pathway
Chemical Stability		
Acid Hydrolysis	0.1 M HCl, 60°C	Potential for hydrolysis of the urea linkage.
Base Hydrolysis	0.1 M NaOH, RT	Potential for hydrolysis of the urea linkage.
Oxidation	3% H ₂ O ₂ , RT	Potential for N-oxidation, particularly at the piperazine nitrogen.
Physical Stability		
Thermal (Solid)	80°C, 7 days	Expected to be stable, but potential for formation of related substances.
Photostability	ICH Q1B Conditions	The dichlorinated phenyl ring may be susceptible to photolytic reactions.

Conclusion

This technical guide provides a comprehensive framework for assessing the physical and chemical stability of **Infigratinib-d3**. A thorough stability program, encompassing forced degradation and ICH-compliant photostability and long-term studies, is essential. Executing these experimental protocols will enable the elucidation of degradation pathways, support the development of a validated stability-indicating analytical method, and establish definitive storage, handling, and re-test period recommendations. This ensures the integrity and reliability of **Infigratinib-d3** when used as an analytical standard in critical drug development and clinical research settings.

Need Custom Synthesis?

BenchChem offers custom synthesis for rare earth carbides and specific isotopic labeling.

Email: info@benchchem.com or [Request Quote Online](#).

References

- [1. go.drugbank.com](https://go.drugbank.com) [go.drugbank.com]
- [2. Infigratinib | Advanced Drug Monograph | MedPath](#) [trial.medpath.com]
- [3. clinicaltrials.eu](https://clinicaltrials.eu) [clinicaltrials.eu]
- [4. Infigratinib: First Approval - PMC](#) [pmc.ncbi.nlm.nih.gov]
- [5. What is Infigratinib used for?](#) [synapse.patsnap.com]
- [6. WITHDRAWN: FDA grants accelerated approval to infigratinib for metastatic cholangiocarcinoma | FDA](#) [fda.gov]
- [7. file.medchemexpress.com](https://file.medchemexpress.com) [file.medchemexpress.com]
- [8. accessdata.fda.gov](https://accessdata.fda.gov) [accessdata.fda.gov]
- [9. selleckchem.com](https://selleckchem.com) [selleckchem.com]
- [10. Frontiers | Signaling Pathway and Small-Molecule Drug Discovery of FGFR: A Comprehensive Review](#) [frontiersin.org]
- [11. nelsonlabs.com](https://nelsonlabs.com) [nelsonlabs.com]
- [12. biopharminternational.com](https://biopharminternational.com) [biopharminternational.com]
- [13. sgs.com](https://sgs.com) [sgs.com]
- [14. An Introduction To Forced Degradation Studies For Drug Substance Drug Product](#) [pharmaceuticalonline.com]
- [15. Forced Degradation Study in Pharmaceutical Stability | Pharmaguideline](#) [pharmaguideline.com]
- [16. database.ich.org](https://database.ich.org) [database.ich.org]
- [17. ema.europa.eu](https://ema.europa.eu) [ema.europa.eu]
- [18. aurigaresearch.com](https://aurigaresearch.com) [aurigaresearch.com]
- [19. 3 Important Photostability Testing Factors](#) [sampled.com]

- To cite this document: BenchChem. [In-depth Technical Guide: Physical and Chemical Stability of Infigratinib-d3]. BenchChem, [2026]. [Online PDF]. Available at: [<https://www.benchchem.com/product/b12377363/docs#in-depth-technical-guide-physical-and-chemical-stability-of-infigratinib-d3>]

Disclaimer & Data Validity:

The information provided in this document is for Research Use Only (RUO) and is strictly not intended for diagnostic or therapeutic procedures. While BenchChem strives to provide accurate protocols, we make no warranties, express or implied, regarding the fitness of this product for every specific experimental setup.

Technical Support: The protocols provided are for reference purposes. Unsure if this reagent suits your experiment?

Need Industrial/Bulk Grade? [Request Custom Synthesis Quote](#)

BenchChem

Our mission is to be the trusted global source of essential and advanced chemicals, empowering scientists and researchers to drive progress in science and industry.

Contact

Address: 3281 E Guasti Rd
Ontario, CA 91761, United States
Phone: (601) 213-4426
Email: info@benchchem.com

[Contact our Ph.D. Support Team for a compatibility check](#)