

# Comparative bioavailability studies of different infigratinib formulations

**Author:** BenchChem Technical Support Team. **Date:** April 2026

## Compound of Interest

Compound Name: *Infigratinib-d3*

Cat. No.: *B12377363*

[Get Quote](#)

## A Comparative Guide to the Bioavailability of Infigratinib Formulations

For Researchers, Scientists, and Drug Development Professionals

This guide provides a comprehensive comparison of the bioavailability of different oral formulations of infigratinib, a selective fibroblast growth factor receptor (FGFR) inhibitor. The information is compiled from publicly available data, including clinical trial information and regulatory documents, to assist researchers and drug development professionals in understanding the pharmacokinetic profiles of various infigratinib formulations.

### Executive Summary

Infigratinib has been developed in several capsule formulations throughout its clinical trial history. These include a Clinical Service Formulation (CSF) and multiple Final Market Image (FMI) formulations (FMI-I, FMI-II, FMI-III, and FMI-IV). Bridging studies were conducted to establish the pharmacokinetic equivalence between these formulations. While specific pharmacokinetic parameters from direct comparative bioavailability studies are not fully available in the public domain, regulatory documents indicate that the different FMI

formulations used in pivotal clinical trials have comparable bioavailability. This guide summarizes the available data and provides context for the formulation development of infigratinib.

## Data Presentation: Pharmacokinetic Comparison

While exact values from head-to-head comparative bioavailability studies are not publicly available, information from regulatory review documents allows for a semi-quantitative comparison between the key formulations used in clinical trials. The following table summarizes the relative bioavailability based on these documents.

Formulation Comparison	Geometric Mean Ratio (Test/Reference)	Finding
FMI-IV vs. FMI-III		
C <sub>max</sub>		Difference of less than 20%
AUC		Difference of less than 20%
FMI-III vs. FMI-I		
C <sub>max</sub>		~29% higher for FMI-III
AUC <sub>last</sub>		~35% higher for FMI-III
AUC <sub>inf</sub>		~21% higher for FMI-III

Note: This data is derived from cross-study comparisons and regulatory reviews. The percentage differences are approximations based on available documentation.

The following table presents pharmacokinetic data for infigratinib from a study in Chinese patients with advanced gastric cancer, which provides a general understanding of the drug's behavior in vivo. The specific formulation used in this study was not detailed.

Parameter	Single Dose (125 mg)	Steady State (125 mg once daily)
C <sub>max</sub> (ng/mL)	85.9 (Geometric Mean)	204 (Geometric Mean)
AUC (h*ng/mL)	637 (AUC <sub>0-t</sub> , Geometric Mean)	3060 (AUC <sub>0-24,ss</sub> , Geometric Mean)
T <sub>max</sub> (h)	3.1 (Median)	4.0 (Median)

## Experimental Protocols

Detailed protocols for the direct comparative bioavailability studies of infigratinib formulations are not publicly accessible. However, regulatory guidance for bioequivalence studies of infigratinib provides a standard methodology that would have been followed.

Study Design for a Comparative Bioavailability Study:

A typical bioequivalence study for a new formulation of infigratinib would follow a randomized, single-dose, two-treatment, two-period, crossover design in healthy subjects under fasting conditions.

- Population: Healthy male and non-pregnant, non-lactating female subjects.
- Treatments:
  - Test Product: A single oral dose of the new infigratinib formulation.
  - Reference Product: A single oral dose of the established infigratinib formulation (e.g., FMI-III).
- Procedure:
  - Subjects are randomized to receive either the test or reference product in the first period.
  - Following an overnight fast, the assigned formulation is administered with a standardized volume of water.

- Serial blood samples are collected at predefined time points before and after dosing to characterize the plasma concentration-time profile of infigratinib. A sufficient number of samples should be taken around the expected  $T_{max}$  and in the elimination phase to accurately determine  $C_{max}$  and AUC.
- After a washout period of sufficient duration to ensure complete elimination of the drug from the body, subjects are crossed over to receive the alternate formulation in the second period.
- The same blood sampling schedule is followed in the second period.
- Pharmacokinetic Analysis: Plasma samples are analyzed for infigratinib concentrations using a validated bioanalytical method. The primary pharmacokinetic parameters ( $C_{max}$ , AUC<sub>0-t</sub>, and AUC<sub>0-∞</sub>) are calculated for each subject for both formulations.
- Statistical Analysis: The log-transformed  $C_{max}$  and AUC parameters are analyzed using an Analysis of Variance (ANOVA) model. The 90% confidence intervals for the ratio of the geometric means (test/reference) for  $C_{max}$  and AUC are calculated to determine if they fall within the predefined bioequivalence limits (typically 80-125%).

## Mandatory Visualizations

### Infigratinib's Mechanism of Action: FGFR Signaling Pathway

Infigratinib is a potent and selective inhibitor of fibroblast growth factor receptors (FGFRs), particularly FGFR1, FGFR2, and FGFR3.<sup>[1]</sup> In certain cancers, alterations in FGFR genes can lead to the production of abnormal FGFR proteins that are constantly active, driving tumor cell growth, proliferation, and survival. Infigratinib works by blocking the signaling from these aberrant FGFRs.

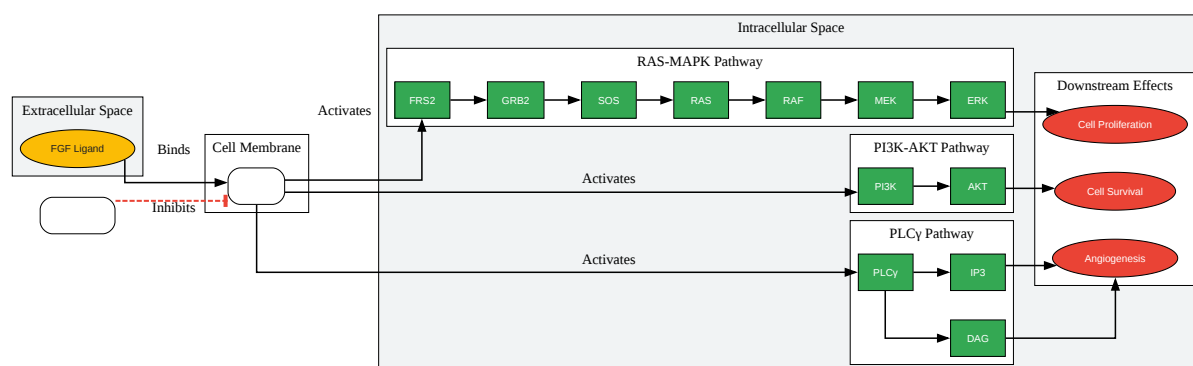

[Click to download full resolution via product page](#)

Caption: Infigratinib inhibits the FGFR signaling pathway.

## Experimental Workflow for a Comparative Bioavailability Study

The following diagram illustrates a typical workflow for a clinical trial designed to compare the bioavailability of two oral drug formulations.

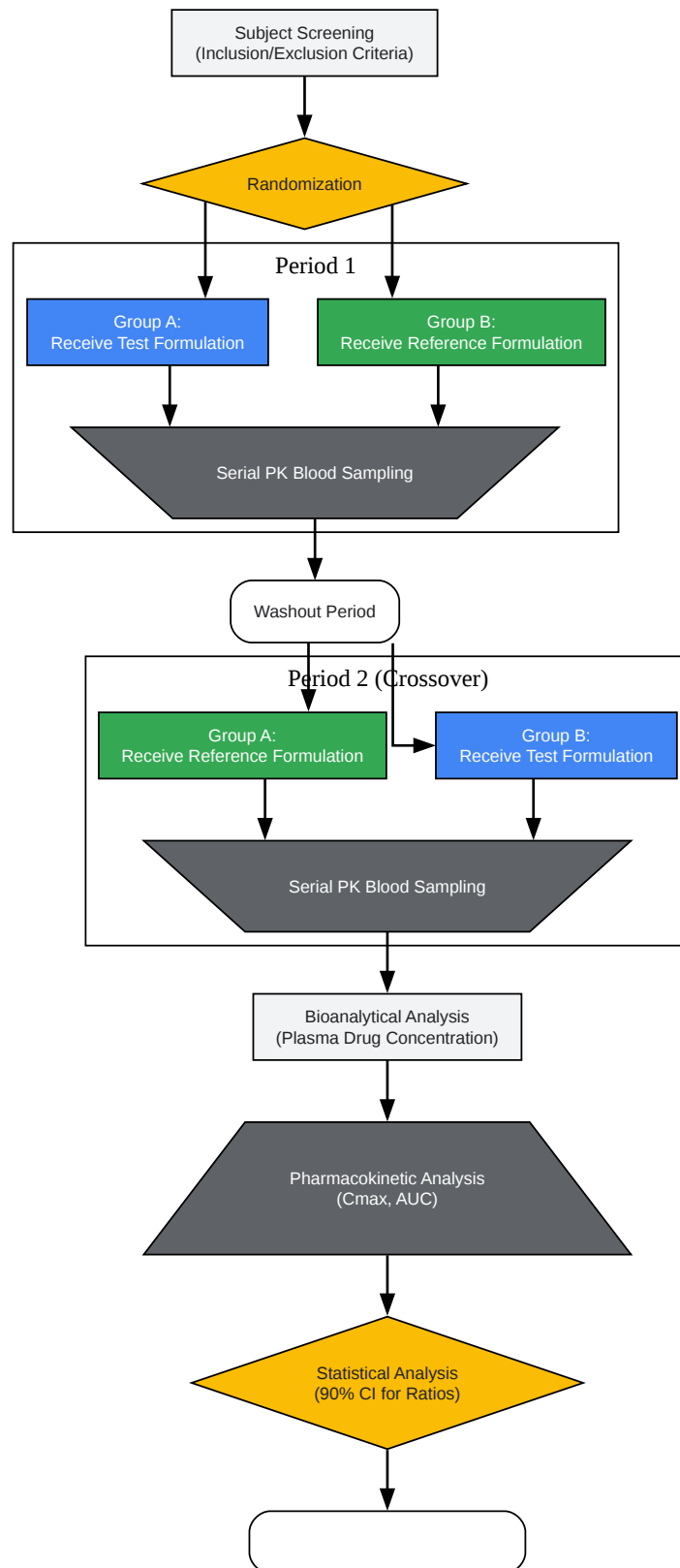

[Click to download full resolution via product page](#)

### Need Custom Synthesis?

BenchChem offers custom synthesis for rare earth carbides and specific isotopic labeling.

Email: [info@benchchem.com](mailto:info@benchchem.com) or [Request Quote Online](#).

## References

- [1. Infigratinib: First Approval - PMC \[pmc.ncbi.nlm.nih.gov\]](#)
- To cite this document: BenchChem. [Comparative bioavailability studies of different infigratinib formulations]. BenchChem, [2026]. [Online PDF]. Available at: [\[https://www.benchchem.com/product/b12377363/docs#comparative-bioavailability-studies-of-different-infigratinib-formulations\]](https://www.benchchem.com/product/b12377363/docs#comparative-bioavailability-studies-of-different-infigratinib-formulations)

### Disclaimer & Data Validity:

The information provided in this document is for Research Use Only (RUO) and is strictly not intended for diagnostic or therapeutic procedures. While BenchChem strives to provide accurate protocols, we make no warranties, express or implied, regarding the fitness of this product for every specific experimental setup.

**Technical Support:** The protocols provided are for reference purposes. Unsure if this reagent suits your experiment?

**Need Industrial/Bulk Grade?** [Request Custom Synthesis Quote](#)

## BenchChem

Our mission is to be the trusted global source of essential and advanced chemicals, empowering scientists and researchers to drive progress in science and industry.

### Contact

Address: 3281 E Guasti Rd

Ontario, CA 91761, United States

Phone: (601) 213-4426

Email: [info@benchchem.com](mailto:info@benchchem.com)

Contact our Ph.D. Support Team for a compatibility check