

Addressing variability in animal studies using BRL-37344

Author: BenchChem Technical Support Team. **Date:** April 2026

Compound of Interest

Compound Name: BRL-37344

CAS No.: 90730-96-4

Cat. No.: B12377262

[Get Quote](#)

Technical Support Center: BRL-37344 Animal Studies

This technical support center provides troubleshooting guidance and frequently asked questions (FAQs) for researchers utilizing **BRL-37344** in animal studies. Variability in experimental outcomes is a common challenge, and this resource aims to provide insights into potential sources of this variability and offer standardized protocols to mitigate them.

Frequently Asked Questions (FAQs)

Q1: What is **BRL-37344** and what is its primary mechanism of action?

A1: **BRL-37344** is a chemical compound that acts as a selective agonist for the β_3 -adrenergic receptor (β_3 -AR).[1] Its primary mechanism of action involves binding to and activating β_3 -ARs, which are predominantly expressed in adipose tissue, the urinary bladder, the myocardium, and the arterial endothelium.[2] This activation stimulates downstream signaling pathways, leading to various physiological responses, including thermogenesis and lipolysis.[2][3]

Q2: What are the common research applications of **BRL-37344** in animal models?

A2: **BRL-37344** has been investigated in a variety of preclinical research areas. Animal studies have utilized this compound to explore its therapeutic potential in:

- Obesity and Diabetes: By activating brown adipose tissue, it can increase energy expenditure and lower blood glucose levels.[4]
- Cardiovascular Diseases: It has been studied for its effects on myocardial ischemia/reperfusion injury and pulmonary hypertension.[5]
- Ocular Diseases: Research has explored its role in inhibiting pathological retinal angiogenesis.[6]
- Urological Conditions: It has been used to investigate the relaxation of detrusor smooth muscle.[1]

Q3: Why am I observing high variability in my animal study results with **BRL-37344**?

A3: Variability in studies using **BRL-37344** can arise from several factors:

- Off-target effects: While being a preferential β 3-AR agonist, **BRL-37344** can also stimulate β 1- and β 2-adrenergic receptors, especially at higher concentrations.[3][7][8] This can lead to cardiovascular effects, such as increased heart rate, that are not mediated by β 3-ARs.[9][10]
- Species-specific differences: The pharmacology of **BRL-37344**, including its affinity for β 3-ARs, can differ between species.[11] For instance, it displays a higher affinity for rodent β 3-ARs compared to human β 3-ARs.[11]
- Animal model characteristics: The age, strain, and health status of the animals can significantly influence the outcomes. For example, the expression of β 3-ARs can be altered in disease states like heart failure.[2]
- Experimental conditions: Factors such as the route of administration, dosage, duration of treatment, and even housing conditions can contribute to variability.[2]

Troubleshooting Guide

Issue 1: Inconsistent or unexpected cardiovascular effects (e.g., tachycardia).

- Question: My study animals are showing an increased heart rate after **BRL-37344** administration, which I did not anticipate. What could be the cause?
- Answer: The positive chronotropic (heart rate increasing) effect of **BRL-37344** is often not a direct effect on cardiac β_3 -adrenoceptors but rather a result of two potential mechanisms:
 - β_1/β_2 -Adrenoceptor Stimulation: At certain concentrations, **BRL-37344** can act on β_1 - and β_2 -adrenoceptors in the heart, leading to increased heart rate and contractility.[\[3\]](#)[\[7\]](#)[\[8\]](#)
 - Baroreflex Mechanism: **BRL-37344** can induce vasodilation through β_3 -AR activation in blood vessels, leading to a drop in blood pressure.[\[9\]](#) This can trigger a compensatory baroreflex, resulting in an increased heart rate.[\[9\]](#)[\[10\]](#)
- Troubleshooting Steps:
 - Co-administration with antagonists: To isolate the β_3 -AR mediated effects, consider co-administering **BRL-37344** with a β_1/β_2 -adrenoceptor antagonist like propranolol.[\[3\]](#)[\[8\]](#) This will block the off-target cardiac effects.
 - Dose-response study: Perform a dose-response study to identify the minimal effective dose of **BRL-37344** for your desired β_3 -AR mediated effect, which may minimize the activation of β_1/β_2 -adrenoceptors.
 - Use sinoaortic denervated animals: In more advanced studies, using animals with denervated baroreceptors can help to distinguish between direct cardiac effects and reflex tachycardia.[\[9\]](#)[\[10\]](#)

Issue 2: Lack of a significant metabolic effect (e.g., no change in body weight or glucose levels).

- Question: I am not observing the expected metabolic benefits, such as weight loss or improved glucose tolerance, in my rodent model. What could be wrong?

- Answer: The metabolic effects of **BRL-37344** are highly dependent on the experimental protocol and the animal model.
- Troubleshooting Steps:
 - Verify Dosage and Administration Route: Ensure that the dosage and route of administration are appropriate for your specific animal model and research question. Refer to the table below for dosages used in various studies.
 - Duration of Treatment: Some metabolic effects may require chronic administration. A single dose might not be sufficient to induce significant changes in body weight.
 - Animal Strain and Age: Different rodent strains can have varying sensitivities to β 3-AR agonists. The age of the animals can also play a role, as the expression and function of β 3-ARs may change over time.
 - Consider Biphasic Effects: In some tissues, like skeletal muscle, **BRL-37344** can have biphasic effects on glucose utilization, with stimulation at low concentrations and inhibition at high concentrations.[12] A careful dose-response analysis is crucial.

Experimental Protocols

General Guidelines for **BRL-37344** Preparation and Administration

- Storage: **BRL-37344** should be stored at room temperature in the continental US, though this may vary elsewhere. For stock solutions, it is recommended to store at -80°C for up to 6 months or -20°C for up to 1 month.[4]
- Vehicle: Saline is a commonly used vehicle for intraperitoneal (i.p.) injections.[13]

Example Protocols from Literature

Animal Model	Application	Dosage	Administration Route	Duration	Key Findings
Obese and diabetic mice	Weight loss and glucose lowering	Not specified	Not specified	Not specified	Significantly lowered body weight.[4]
X-linked nephrogenic diabetes insipidus (X-NDI) mice	Antidiuretic effect	1 mg/kg	Intraperitoneal (i.p.) injection	Single injection and repeated injections every 4 hours for 24 hours	Promoted short-lasting reabsorption of water and solutes.[13]
Sprague-Dawley rat pups	Prevention of hyperoxia-induced colonic alterations	1, 3, and 6 mg/kg	Subcutaneous injection	Daily from birth to day 14	3 mg/kg prevented alterations; 6 mg/kg was toxic.[14]
Porcine model of chronic pulmonary hypertension	Reduction of pulmonary vascular resistance	10 µg/kg/day	Intravenous infusion	14 days	Significant reduction in pulmonary vascular resistance index and increase in cardiac index. [5]
Canine models of atrial fibrillation	Investigation of atrial structural remodeling	1.5 µg/kg/h	Intraperitoneal injection via osmotic pump	4 weeks	Exacerbated atrial structural remodeling. [15]

Signaling Pathways and Experimental Workflows

BRL-37344 Signaling Pathways

The activation of β 3-adrenergic receptors by **BRL-37344** initiates several downstream signaling cascades. The diagram below illustrates the key pathways involved.

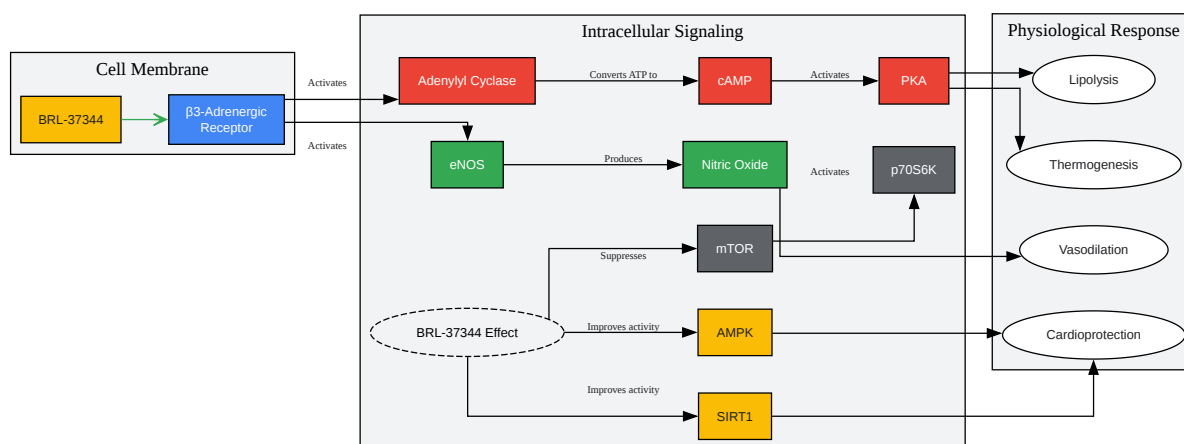

[Click to download full resolution via product page](#)

Caption: **BRL-37344** signaling pathways.

Experimental Workflow for Investigating Off-Target Effects

To determine if the observed effects of **BRL-37344** are mediated by β 3-ARs or have off-target effects on β 1/ β 2-ARs, the following experimental workflow can be employed.

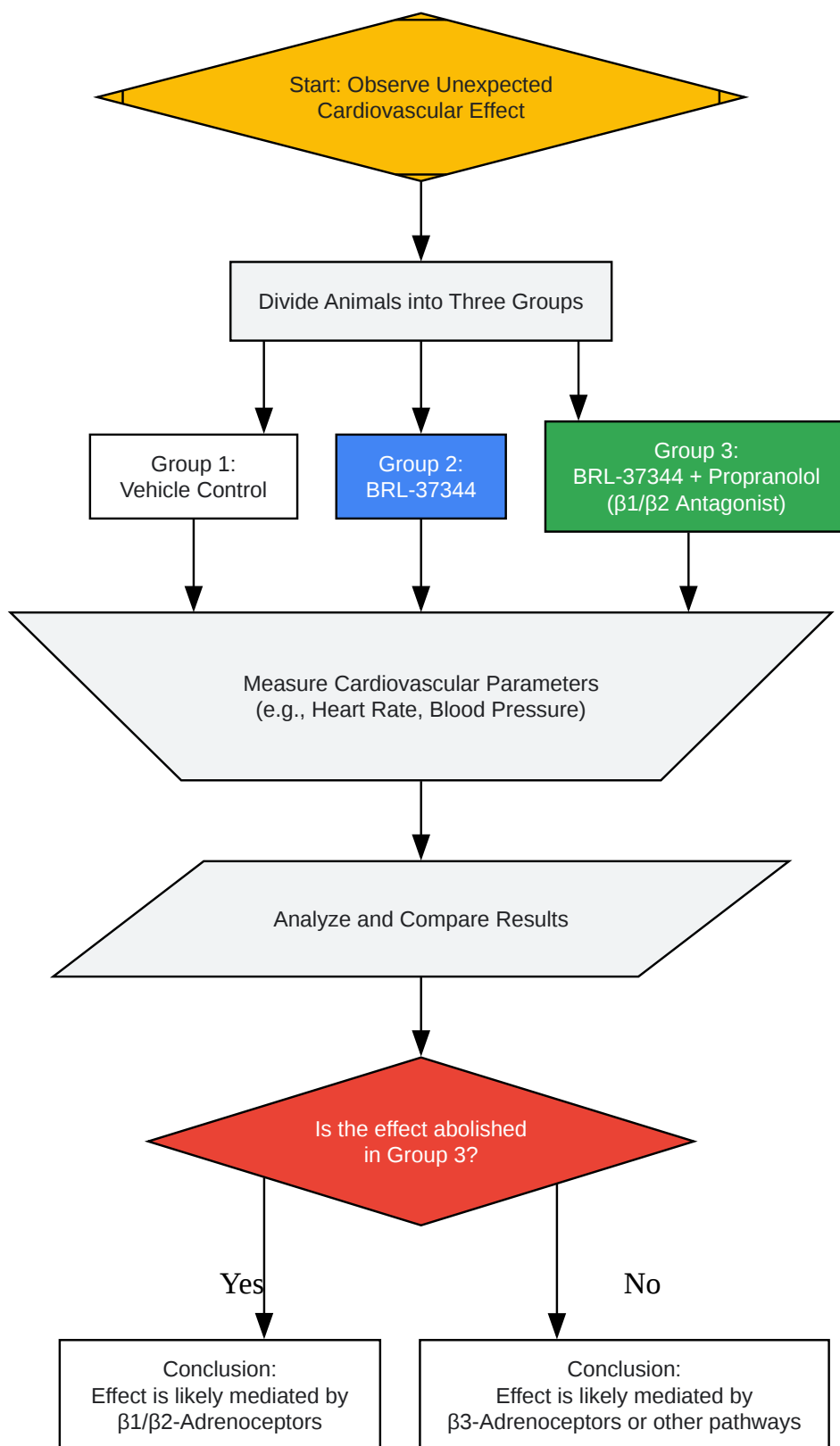

[Click to download full resolution via product page](#)

Caption: Workflow to dissect **BRL-37344**'s receptor-specific effects.

Need Custom Synthesis?

BenchChem offers custom synthesis for rare earth carbides and specific isotopic labeling.

Email: info@benchchem.com or [Request Quote Online](#).

References

- [1. BRL-37344 - Wikipedia \[en.wikipedia.org\]](#)
- [2. Therapeutic Potential of the \$\beta\$ 3-Adrenergic Receptor and Its Ligands in Cardiovascular Diseases \[mdpi.com\]](#)
- [3. The preferential \$\beta\$ 3-adrenoceptor agonist BRL 37344 increases force via \$\beta\$ 1-/ \$\beta\$ 2-adrenoceptors and induces endothelial nitric oxide synthase via \$\beta\$ 3-adrenoceptors in human atrial myocardium - PMC \[pmc.ncbi.nlm.nih.gov\]](#)
- [4. medchemexpress.com \[medchemexpress.com\]](#)
- [5. Beta-3 adrenergic agonists reduce pulmonary vascular resistance and improve right ventricular performance in a porcine model of chronic pulmonary hypertension - PMC \[pmc.ncbi.nlm.nih.gov\]](#)
- [6. Agonism of \$\beta\$ 3-Adrenoceptors Inhibits Pathological Retinal Angiogenesis in the Model of Oxygen-Induced Retinopathy - PMC \[pmc.ncbi.nlm.nih.gov\]](#)
- [7. The preferential \$\beta\$ 3-adrenoceptor agonist BRL 37344 increases force via \$\beta\$ 1-/ \$\beta\$ 2-adrenoceptors and induces endothelial nitric oxide synthase via \$\beta\$ 3-adrenoceptors in human atrial myocardium | Semantic Scholar \[semanticscholar.org\]](#)
- [8. The preferential beta3-adrenoceptor agonist BRL 37344 increases force via beta1-/beta2-adrenoceptors and induces endothelial nitric oxide synthase via beta3-adrenoceptors in human atrial myocardium - PubMed \[pubmed.ncbi.nlm.nih.gov\]](#)
- [9. The positive chronotropic effect induced by BRL 37344 and CGP 12177, two beta-3 adrenergic agonists, does not involve cardiac beta adrenoceptors but baroreflex mechanisms - PubMed \[pubmed.ncbi.nlm.nih.gov\]](#)
- [10. Redirecting \[linkinghub.elsevier.com\]](#)
- [11. Everything You Always Wanted to Know about \$\beta\$ 3-AR * \(* But Were Afraid to Ask\) - PMC \[pmc.ncbi.nlm.nih.gov\]](#)
- [12. Biphasic effects of the beta-adrenoceptor agonist, BRL 37344, on glucose utilization in rat isolated skeletal muscle - PMC \[pmc.ncbi.nlm.nih.gov\]](#)

- [13. The \$\beta\$ 3-AR agonist BRL37344 ameliorates the main symptoms of X-linked nephrogenic diabetes insipidus in the mouse model of the disease - PMC \[pmc.ncbi.nlm.nih.gov\]](#)
- [14. mdpi.com \[mdpi.com\]](#)
- [15. karger.com \[karger.com\]](#)
- To cite this document: BenchChem. [Addressing variability in animal studies using BRL-37344]. BenchChem, [2026]. [Online PDF]. Available at: [\[https://www.benchchem.com/product/b12377262/docs#addressing-variability-in-animal-studies-using-brl-37344\]](https://www.benchchem.com/product/b12377262/docs#addressing-variability-in-animal-studies-using-brl-37344)

Disclaimer & Data Validity:

The information provided in this document is for Research Use Only (RUO) and is strictly not intended for diagnostic or therapeutic procedures. While BenchChem strives to provide accurate protocols, we make no warranties, express or implied, regarding the fitness of this product for every specific experimental setup.

Technical Support: The protocols provided are for reference purposes. Unsure if this reagent suits your experiment?

Need Industrial/Bulk Grade? [Request Custom Synthesis Quote](#)

BenchChem

Our mission is to be the trusted global source of essential and advanced chemicals, empowering scientists and researchers to drive progress in science and industry.

Contact

Address: 3281 E Guasti Rd
Ontario, CA 91761, United States
Phone: (601) 213-4426
Email: info@benchchem.com

[Contact our Ph.D. Support Team for a compatibility check](#)

