

SJ1008030 Formic: A Comparative Analysis of Kinase Cross-Reactivity

Author: BenchChem Technical Support Team. **Date:** April 2026

Compound of Interest

Compound Name: SJ1008030 formic

Cat. No.: B12376149

[Get Quote](#)

For Immediate Release

SJ1008030 formic demonstrates high selectivity as a potent Janus kinase 2 (JAK2) degrader with minimal off-target effects on other kinases, positioning it as a precise tool for research in JAK2-driven signaling pathways and related pathologies.

Developed as a proteolysis-targeting chimera (PROTAC), **SJ1008030 formic** is designed to specifically induce the degradation of JAK2, a key protein in the JAK-STAT signaling pathway implicated in various cancers and inflammatory diseases. This guide provides a comparative analysis of its cross-reactivity with other kinases, supported by experimental data, to offer researchers and drug development professionals a clear understanding of its selectivity profile.

Kinase Selectivity Profile of SJ1008030 formic

Experimental data indicates that **SJ1008030 formic** is a highly selective degrader of JAK2. While it potently induces the degradation of JAK2, it exhibits significantly weaker effects on the closely related kinases, JAK1 and JAK3. Furthermore, it does not induce the degradation of GSPT1, a known off-target of some PROTACs that utilize the cereblon (CRBN) E3 ligase.

Target Kinase	Effect of SJ1008030 formic
JAK2	Potent Degradation
JAK1	Weak Degradation
JAK3	Weak Degradation
GSPT1	No Degradation

This high degree of selectivity is crucial for minimizing potential side effects and ensuring that observed biological outcomes can be confidently attributed to the degradation of JAK2.

Signaling Pathway and Mechanism of Action

SJ1008030 formic functions as a heterobifunctional molecule. One end binds to the target protein, JAK2, while the other end recruits an E3 ubiquitin ligase. This proximity induces the ubiquitination of JAK2, marking it for degradation by the proteasome. This targeted degradation approach offers a distinct advantage over traditional kinase inhibitors, which only block the kinase activity and may not address the non-catalytic functions of the protein.

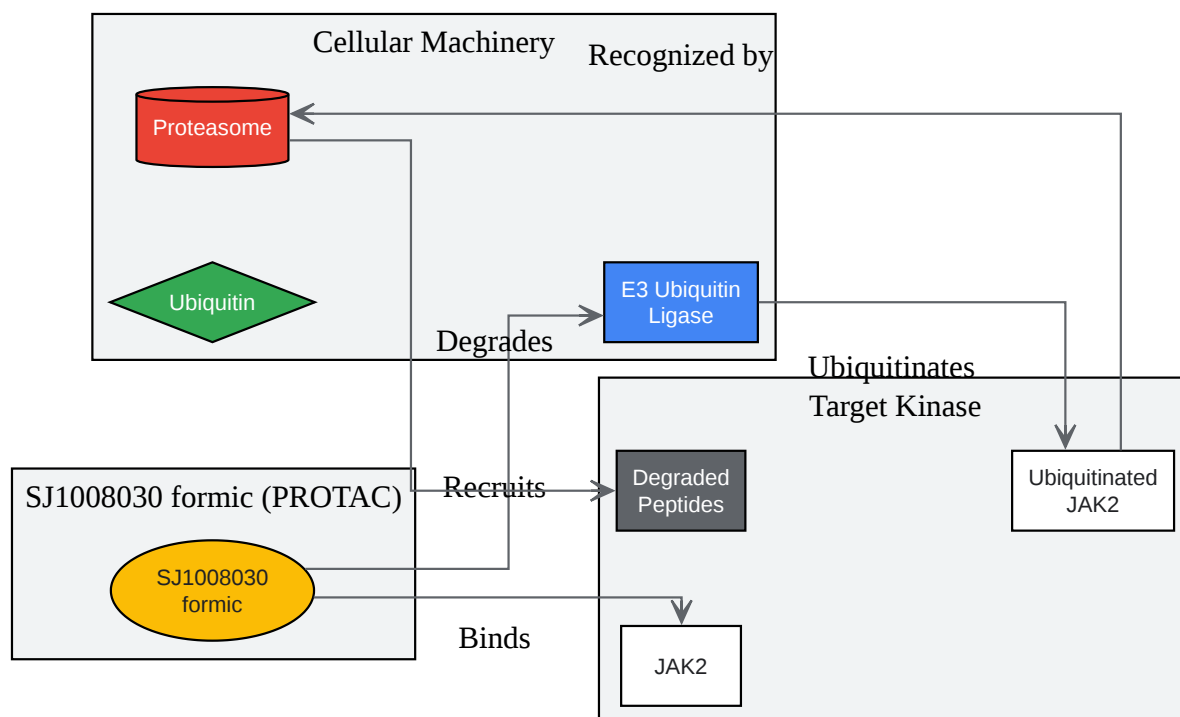

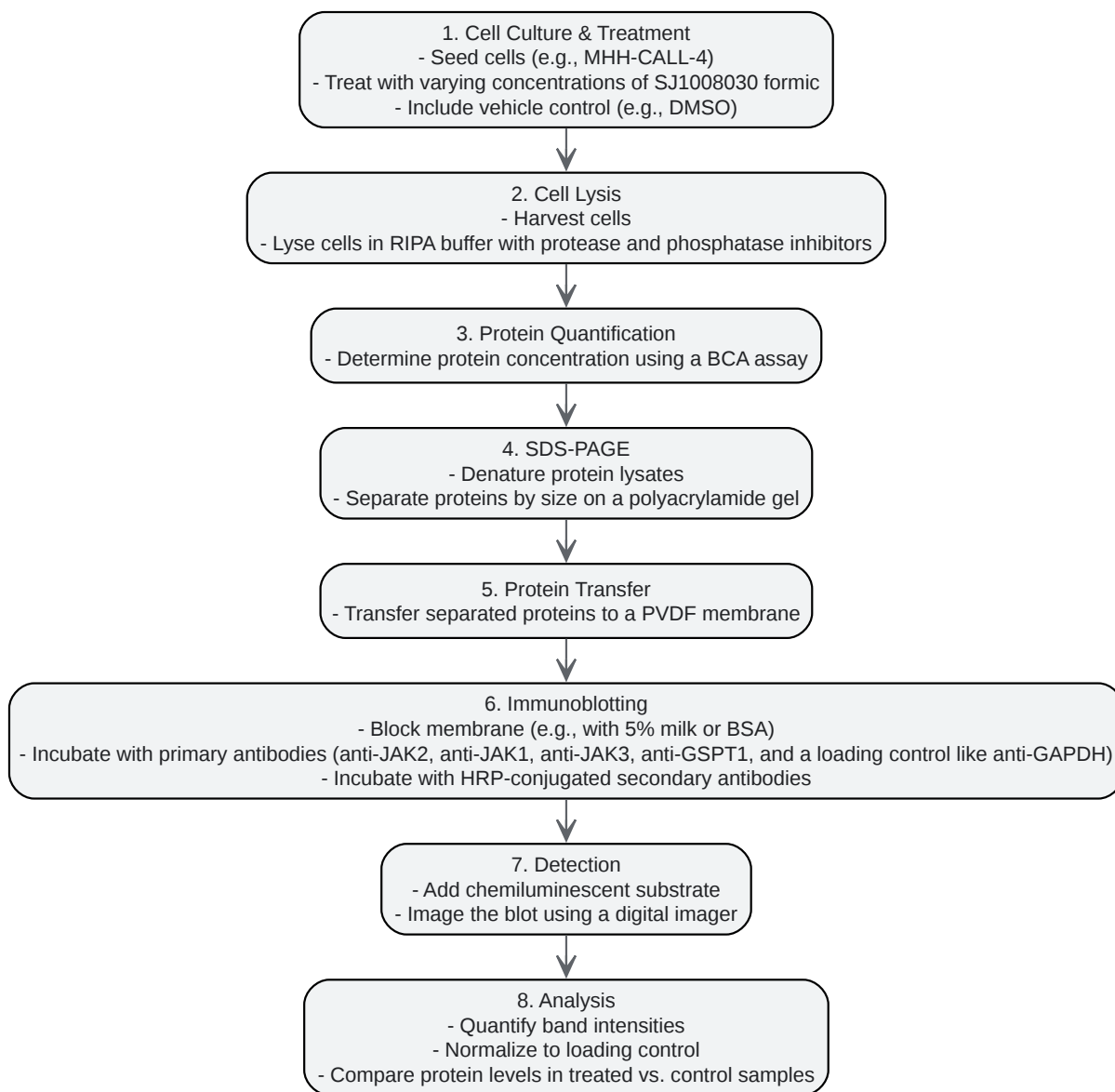

[Click to download full resolution via product page](#)

- To cite this document: BenchChem. [SJ1008030 Formic: A Comparative Analysis of Kinase Cross-Reactivity]. BenchChem, [2026]. [Online PDF]. Available at: [\[https://www.benchchem.com/product/b12376149/docs#sj1008030-formic-a-comparative-analysis-of-kinase-cross-reactivity\]](https://www.benchchem.com/product/b12376149/docs#sj1008030-formic-a-comparative-analysis-of-kinase-cross-reactivity)

Disclaimer & Data Validity:

The information provided in this document is for Research Use Only (RUO) and is strictly not intended for diagnostic or therapeutic procedures. While BenchChem strives to provide accurate protocols, we make no warranties, express or implied, regarding the fitness of this product for every specific experimental setup.

Technical Support: The protocols provided are for reference purposes. Unsure if this reagent suits your experiment?

Need Industrial/Bulk Grade? [Request Custom Synthesis Quote](#)

BenchChem

Our mission is to be the trusted global source of essential and advanced chemicals, empowering scientists and researchers to drive progress in science and industry.

Contact

Address: 3281 E Guasti Rd
Ontario, CA 91761, United States
Phone: (601) 213-4426
Email: info@benchchem.com

[Contact our Ph.D. Support Team for a compatibility check](#)