

Combination Therapy of FGFR1 Inhibitors with Chemotherapy: A Comparative Guide

Author: BenchChem Technical Support Team. **Date:** April 2026

Compound of Interest

Compound Name: *FGFR1 inhibitor-10*

Cat. No.: *B12376286*

[Get Quote](#)

For Researchers, Scientists, and Drug Development Professionals

The strategic combination of targeted therapies with conventional chemotherapy is a promising approach to enhance anti-tumor efficacy and overcome resistance. This guide provides a comparative overview of the preclinical evidence supporting the combination of Fibroblast Growth Factor Receptor 1 (FGFR1) inhibitors with standard chemotherapeutic agents. The data presented herein is intended to inform researchers and drug development professionals on the synergistic potential and underlying mechanisms of these combination therapies. For the purpose of this guide, we will focus on two well-characterized selective FGFR inhibitors, AZD4547 and Infigratinib (BGJ398), as representative examples of "**FGFR1 inhibitor-10**".

Executive Summary

Preclinical studies have demonstrated that combining FGFR1 inhibitors with chemotherapeutic agents like paclitaxel and cisplatin results in synergistic anti-tumor effects across various cancer models. This synergy is attributed to the dual targeting of critical cancer pathways: the FGFR1 inhibitor blocks the pro-survival and proliferative signaling mediated by the aberrant FGFR1 pathway, while chemotherapy induces DNA damage and mitotic catastrophe. The

combination often leads to enhanced apoptosis, increased cell cycle arrest, and more profound tumor growth inhibition than either agent alone.

Comparative Efficacy Data

The following tables summarize the quantitative data from preclinical studies, comparing the efficacy of FGFR1 inhibitor monotherapy, chemotherapy monotherapy, and the combination therapy.

In Vitro Cell Viability

Cancer Type	Cell Line	FGFR1 Inhibitor	Chemotherapy	IC50 (Chemotherapy Alone)	IC50 (Chemotherapy + FGFR1 Inhibitor)	Fold Sensitization
Non-Small Cell Lung Cancer	A549	AZD4547 (5 µM)	nab-Paclitaxel	144.4 nM[1]	35.78 nM[1]	~4.0x
Non-Small Cell Lung Cancer	PC9	AZD4547 (5 µM)	nab-Paclitaxel	202.9 nM[1]	122.5 nM[1]	~1.7x

In Vivo Tumor Growth Inhibition

Cancer Model	FGFR1 Inhibitor	Chemotherapy	Monotherapy TGI (%)	Combination TGI (%)	Synergistic Effect
SCLC Xenograft	Infigratinib (BGJ398)	Cisplatin	Not specified	Significantly greater than monotherapy	Pronounced tumor suppression and survival benefits[2]
NSCLC Xenograft (PC9)	AZD4547	nab-Paclitaxel	AZD4547: Minimal; nab-Paclitaxel: Moderate	Significantly greater than monotherapy	Synergistic antitumor effect[1][3]

Signaling Pathways and Mechanisms of Synergy

The synergistic effect of combining FGFR1 inhibitors with chemotherapy stems from the complementary mechanisms of action of these two classes of drugs.

FGFR1 Signaling Pathway

FGFR1 is a receptor tyrosine kinase that, upon activation by fibroblast growth factors (FGFs), dimerizes and autophosphorylates, initiating a cascade of downstream signaling pathways crucial for cell proliferation, survival, and angiogenesis. The two major pathways activated by FGFR1 are the RAS-MAPK pathway and the PI3K-AKT pathway.

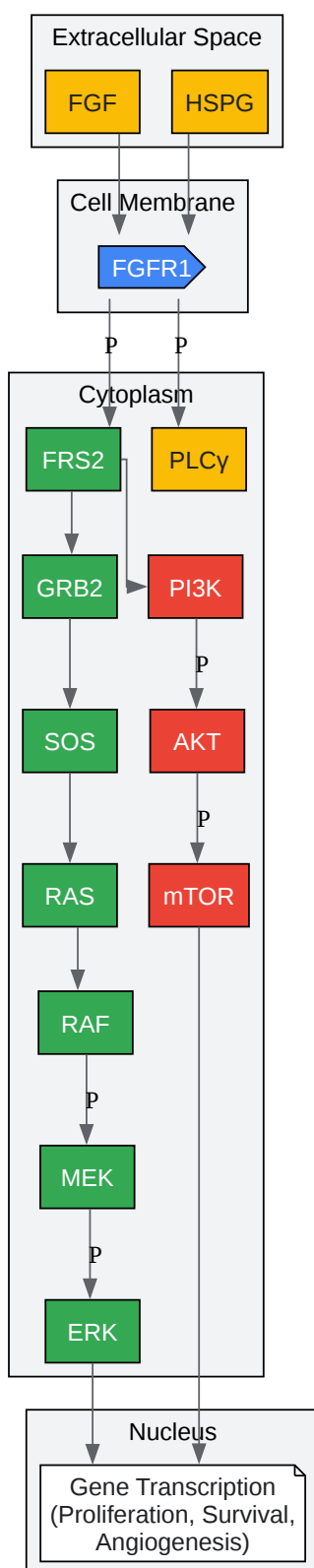

[Click to download full resolution via product page](#)

FGFR1 Signaling Pathway

Mechanism of Synergy

The combination of an FGFR1 inhibitor with a chemotherapeutic agent creates a multi-pronged attack on cancer cells. The FGFR1 inhibitor blocks the key survival signals, making the cancer cells more susceptible to the cytotoxic effects of chemotherapy.

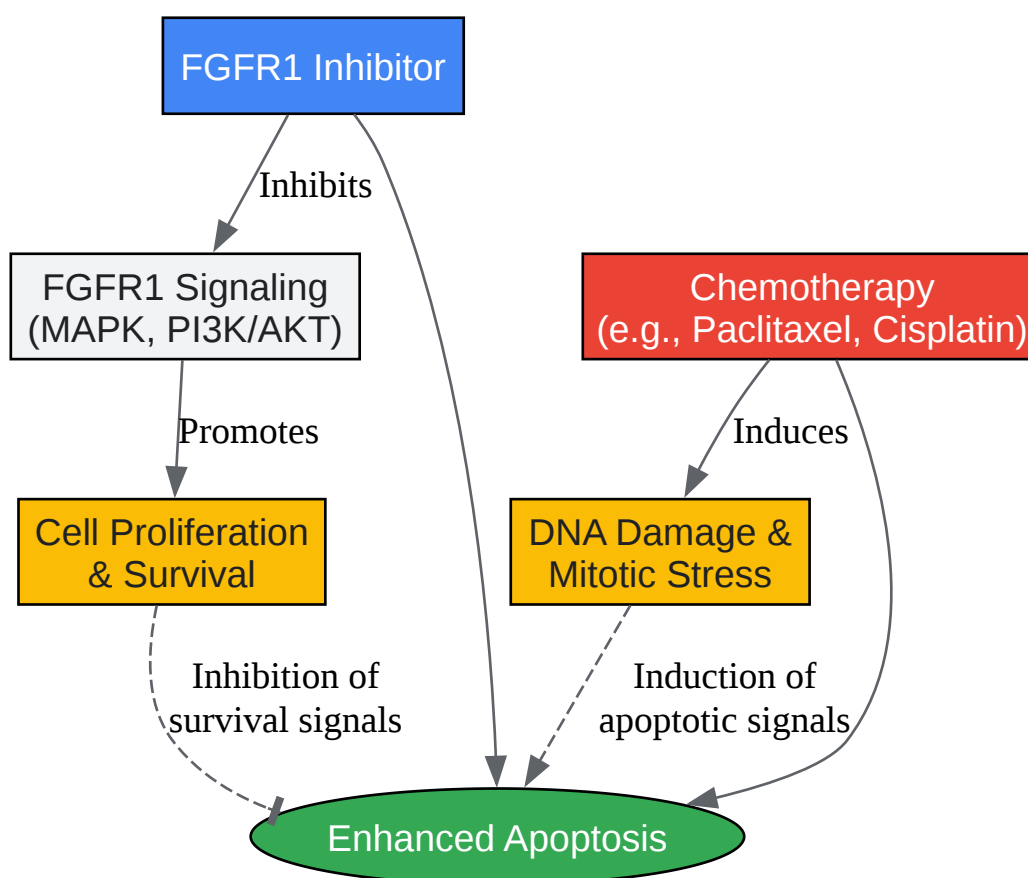

[Click to download full resolution via product page](#)

Synergistic Interaction

Experimental Protocols

Detailed methodologies for the key experiments are provided below. These protocols are representative of those used in the cited preclinical studies.

Cell Viability Assay (MTT Assay)

Objective: To determine the cytotoxic effects of the FGFR1 inhibitor, chemotherapy, and their combination on cancer cell lines.

Protocol:

- **Cell Seeding:** Seed cancer cells (e.g., A549, PC9) in 96-well plates at a density of 5×10^3 cells/well and allow them to adhere overnight.
- **Drug Treatment:** Treat the cells with increasing concentrations of the FGFR1 inhibitor (e.g., AZD4547) or chemotherapy (e.g., nab-paclitaxel) alone, or in combination, for a specified duration (e.g., 24, 48, or 72 hours). A vehicle control (e.g., DMSO) should be included.
- **MTT Addition:** After the incubation period, add 20 μ L of MTT solution (5 mg/mL in PBS) to each well and incubate for 4 hours at 37°C.
- **Formazan Solubilization:** Remove the medium and add 150 μ L of DMSO to each well to dissolve the formazan crystals.
- **Absorbance Measurement:** Measure the absorbance at 490 nm using a microplate reader.
- **Data Analysis:** Calculate the cell viability as a percentage of the control and determine the IC50 values using non-linear regression analysis.

Western Blot Analysis

Objective: To assess the effect of the combination therapy on the phosphorylation status of key proteins in the FGFR1 signaling pathway.

Protocol:

- **Cell Lysis:** Treat cells with the FGFR1 inhibitor, chemotherapy, or their combination for the desired time. Lyse the cells in RIPA buffer containing protease and phosphatase inhibitors.
- **Protein Quantification:** Determine the protein concentration of the lysates using a BCA protein assay.
- **SDS-PAGE:** Separate equal amounts of protein (e.g., 20-40 μ g) on a 10% SDS-polyacrylamide gel.
- **Protein Transfer:** Transfer the separated proteins to a PVDF membrane.

- **Blocking:** Block the membrane with 5% non-fat milk or BSA in TBST for 1 hour at room temperature.
- **Primary Antibody Incubation:** Incubate the membrane with primary antibodies against target proteins (e.g., p-FGFR, FGFR, p-ERK, ERK, p-AKT, AKT, and a loading control like GAPDH or β -actin) overnight at 4°C. Antibody dilutions should be optimized according to the manufacturer's instructions (typically ranging from 1:1000 to 1:2000).
- **Secondary Antibody Incubation:** Wash the membrane with TBST and incubate with HRP-conjugated secondary antibodies (1:5000) for 1 hour at room temperature.
- **Detection:** Visualize the protein bands using an enhanced chemiluminescence (ECL) detection system.

In Vivo Xenograft Study

Objective: To evaluate the anti-tumor efficacy of the combination therapy in a preclinical animal model.

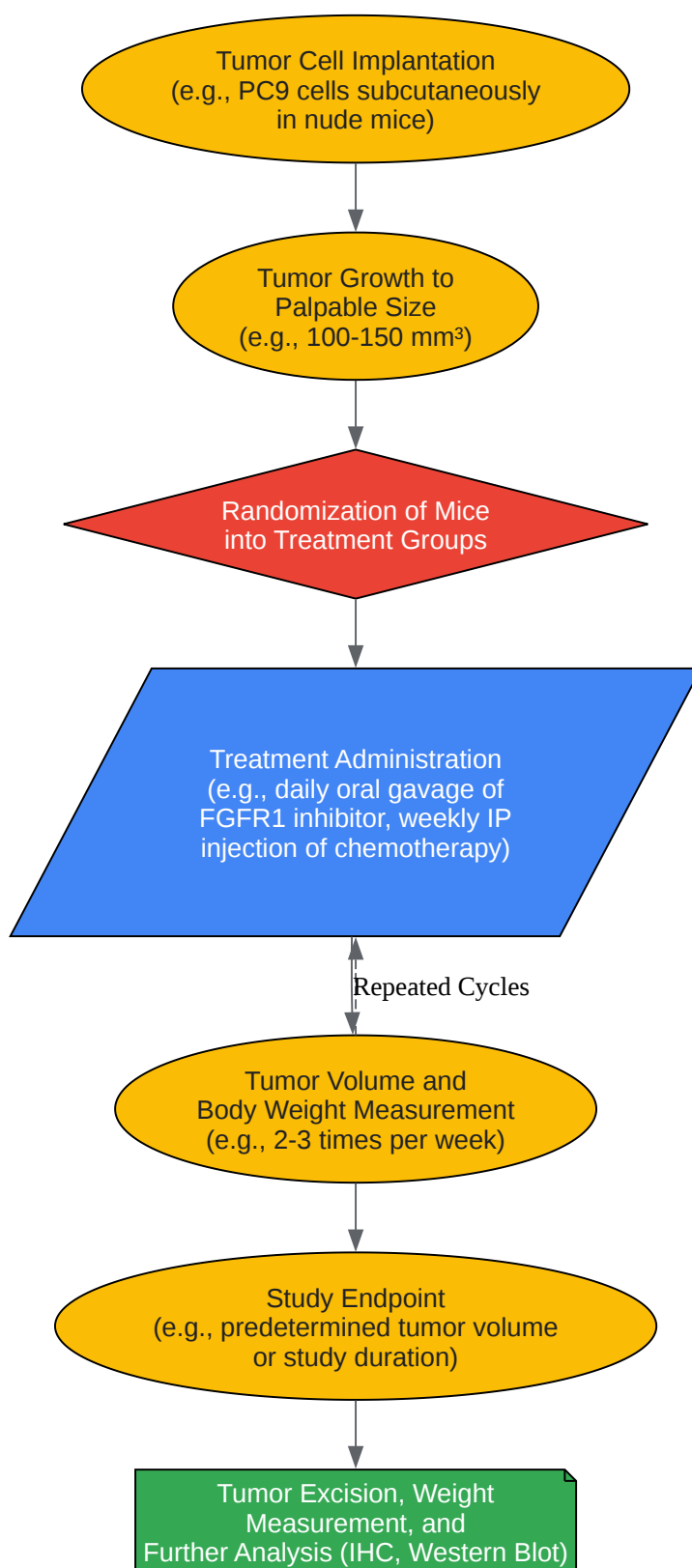

[Click to download full resolution via product page](#)

In Vivo Xenograft Experimental Workflow

Protocol:

- **Animal Model:** Use immunodeficient mice (e.g., BALB/c nude mice, 4-6 weeks old).
- **Tumor Cell Implantation:** Subcutaneously inject a suspension of cancer cells (e.g., 5×10^6 PC9 cells in 100 μ L of PBS) into the right flank of each mouse.
- **Tumor Growth and Randomization:** Monitor tumor growth with calipers. When tumors reach a volume of approximately 100-150 mm^3 , randomize the mice into treatment groups (e.g., Vehicle control, FGFR1 inhibitor alone, Chemotherapy alone, Combination therapy).
- **Drug Administration:** Administer the drugs according to a predetermined schedule. For example, AZD4547 might be given orally at 12.5 mg/kg daily, and paclitaxel administered intraperitoneally at 10 mg/kg once a week.
- **Monitoring:** Measure tumor volume and body weight 2-3 times per week. Tumor volume can be calculated using the formula: $(\text{length} \times \text{width}^2)/2$.
- **Endpoint and Analysis:** Euthanize the mice when tumors reach a predetermined maximum size or at the end of the study period. Excise the tumors, weigh them, and process them for further analysis such as immunohistochemistry or western blotting.

Conclusion

The preclinical data strongly suggest that the combination of FGFR1 inhibitors with standard chemotherapy is a viable and promising strategy for the treatment of cancers with aberrant FGFR1 signaling. The synergistic effects observed in vitro and in vivo provide a solid rationale for the clinical investigation of these combination therapies. Further studies are warranted to optimize dosing and schedules and to identify predictive biomarkers to select patients who are most likely to benefit from this therapeutic approach.

Need Custom Synthesis?

BenchChem offers custom synthesis for rare earth carbides and specific isotopic labeling.

Email: info@benchchem.com or [Request Quote Online](#).

References

- [1. FGFR inhibitors combined with nab-paclitaxel - A promising strategy to treat non-small cell lung cancer and overcome resistance - PMC \[pmc.ncbi.nlm.nih.gov\]](#)
- [2. Apoptosis Induction with Combined Use of Cisplatin and Fisetin in Cisplatin-Resistant Ovarian Cancer Cells \(A2780\) - PMC \[pmc.ncbi.nlm.nih.gov\]](#)
- [3. researchgate.net \[researchgate.net\]](#)
- To cite this document: BenchChem. [Combination Therapy of FGFR1 Inhibitors with Chemotherapy: A Comparative Guide]. BenchChem, [2026]. [Online PDF]. Available at: [<https://www.benchchem.com/product/b12376286/docs#combination-therapy-of-fgfr1-inhibitors-with-chemotherapy-a-comparative-guide>]

Disclaimer & Data Validity:

The information provided in this document is for Research Use Only (RUO) and is strictly not intended for diagnostic or therapeutic procedures. While BenchChem strives to provide accurate protocols, we make no warranties, express or implied, regarding the fitness of this product for every specific experimental setup.

Technical Support: The protocols provided are for reference purposes. Unsure if this reagent suits your experiment?

Need Industrial/Bulk Grade? [Request Custom Synthesis Quote](#)

BenchChem

Our mission is to be the trusted global source of essential and advanced chemicals, empowering scientists and researchers to drive progress in science and industry.

Contact

Address: 3281 E Guasti Rd

Ontario, CA 91761, United States

Phone: (601) 213-4426

Email: info@benchchem.com

Contact our Ph.D. Support Team for a compatibility check