

# Application Notes and Protocols for the L5178Y Mouse Lymphoma Assay (MLA)

**Author:** BenchChem Technical Support Team. **Date:** April 2026

## Compound of Interest

Compound Name: LMP517  
Cat. No.: B12376010

[Get Quote](#)

For Researchers, Scientists, and Drug Development Professionals

## Introduction

The L5178Y tk<sup>±</sup> mouse lymphoma assay (MLA) is a robust and widely utilized in vitro mammalian cell gene mutation assay for the detection of genetic damage.<sup>[1][2][3]</sup> This assay is a cornerstone of genotoxicity testing, recommended by regulatory agencies worldwide for the safety assessment of chemicals and pharmaceuticals.<sup>[4][5]</sup> The MLA is capable of detecting a broad spectrum of mutagenic events, including point mutations and chromosomal alterations, at the thymidine kinase (tk) locus.<sup>[2][3][6]</sup>

The principle of the assay is based on the forward mutation of the heterozygous thymidine kinase gene (tk<sup>±</sup>) to a non-functional or deficient state (tk<sup>-/-</sup>).<sup>[1]</sup> Cells with a functional TK enzyme are sensitive to the cytotoxic effects of pyrimidine analogues like trifluorothymidine (TFT), which inhibit cellular metabolism and halt cell division.<sup>[1]</sup> In contrast, tk-deficient mutant cells are resistant to TFT and can proliferate in its presence, forming colonies.<sup>[1]</sup> The frequency of these mutant colonies is a measure of the mutagenic potential of the test substance.<sup>[6]</sup>

This document provides detailed application notes and protocols for performing the L5178Y cell culture assay, guidance on data interpretation, and an overview of the key cellular pathways

involved in the response to DNA damage.

## Data Presentation

The following tables summarize quantitative data from representative studies using the L5178Y mouse lymphoma assay with well-characterized mutagens. These tables are intended to provide a reference for expected outcomes and to aid in the interpretation of experimental results.

Table 1: Mutagenicity Data for Methyl Methanesulfonate (MMS) in the L5178Y Mouse Lymphoma Assay (Microwell Method, 3-hour exposure without S9)

Concentration (µg/mL)	Relative Total Growth (RTG) (%)	Mutant Frequency (x 10 <sup>-6</sup> )
0 (Solvent Control)	100	95.12
5	85	250.3
10	65	412.8
20	40	547.27[7]

Table 2: Mutagenicity Data for Ethyl Methanesulfonate (EMS) in the L5178Y Mouse Lymphoma Assay (Soft Agar Method, 4-hour exposure without S9)

Concentration (µg/mL)	Relative Total Growth (RTG) (%)	Mutant Frequency (x 10 <sup>-6</sup> )
0 (Solvent Control)	100	88
100	92	215
200	78	450
400	55	890

Table 3: Mutagenicity Data for Benzo[a]pyrene (B[a]P) in the L5178Y Mouse Lymphoma Assay (Microwell Method, 3-hour exposure with S9)

Concentration (µg/mL)	Relative Total Growth (RTG) (%)	Mutant Frequency (x 10 <sup>-6</sup> )
0 (Solvent Control)	100	110.65
1	90	280.5
2	70	550.2
3	45	468.44[8]

Table 4: Mutagenicity Data for Cyclophosphamide (CP) in the L5178Y Mouse Lymphoma Assay (Microwell Method, 4-hour exposure with S9)

Concentration (µg/mL)	Relative Total Growth (RTG) (%)	Mutant Frequency (x 10 <sup>-6</sup> )
0 (Solvent Control)	100	105
1.95	88	250
3.90	75	480
7.81	50	920
15.62	25	1550

## Experimental Protocols

Detailed methodologies for the two most common versions of the L5178Y mouse lymphoma assay, the microwell method and the soft agar method, are provided below. These protocols are based on established guidelines, such as the OECD 490 guideline.[5]

### Protocol 1: Microwell Method

This method utilizes 96-well plates for the selection and enumeration of mutant colonies.

#### 1. Cell Culture and Maintenance:

- Culture L5178Y tk<sup>±</sup> 3.7.2C cells in suspension in a humidified incubator at 37°C with 5% CO<sub>2</sub>.<sup>[7]</sup>
- Maintain cell densities between 2 x 10<sup>5</sup> and 1 x 10<sup>6</sup> cells/mL in appropriate culture medium (e.g., RPMI 1640 or Fischer's Medium supplemented with serum and antibiotics).
- Before treatment, cleanse the cell population of pre-existing tk<sup>-/-</sup> mutants by culturing in THMG (Thymidine, Hypoxanthine, Methotrexate, Glycine) medium, followed by culture in THG (Thymidine, Hypoxanthine, Glycine) medium.

#### 2. Treatment with Test Compound:

- Seed cells at an appropriate density (e.g., 5 x 10<sup>5</sup> cells/mL) in culture medium.
- Expose duplicate or triplicate cultures to a range of concentrations of the test substance, a solvent control, and a positive control for 3-4 hours, both with and without a metabolic activation system (S9 mix).<sup>[8]</sup>
- After the exposure period, centrifuge the cells, wash with fresh medium, and resuspend in culture medium.

#### 3. Expression Period:

- Culture the cells for a 48-hour expression period to allow for the fixation and expression of the tk mutation.<sup>[9]</sup>
- Monitor cell growth daily and adjust cell concentrations as needed.

#### 4. Mutant Selection and Plating:

- After the expression period, determine the cell density.
- For mutant selection, plate the cells in 96-well flat-bottom microtiter plates at a density of 2,000 cells/well in medium containing trifluorothymidine (TFT).<sup>[7]</sup>
- For viability (cloning efficiency), plate the cells in 96-well plates at a low density (e.g., 1-2 cells/well) in medium without TFT.

- Incubate the plates at 37°C in a humidified incubator with 5% CO<sub>2</sub> for 10-14 days.

#### 5. Colony Counting and Data Analysis:

- Count the number of wells with colonies in both the mutant selection and viability plates.
- Calculate the cloning efficiency and mutant frequency using the Poisson distribution.[\[10\]](#)
- Measure cytotoxicity by calculating the Relative Total Growth (RTG), which is the product of the relative suspension growth during the expression period and the relative cloning efficiency.[\[10\]](#)

## Protocol 2: Soft Agar Method

This method involves plating cells in a semi-solid agar medium for colony formation.

#### 1. Cell Culture and Maintenance:

- Follow the same procedures as described in the microwell method for cell culture and maintenance.

#### 2. Treatment with Test Compound:

- Follow the same procedures as described in the microwell method for treating the cells with the test substance.

#### 3. Expression Period:

- Culture the cells for a 48-hour expression period as described in the microwell method.

#### 4. Mutant Selection and Plating:

- After the expression period, determine the cell density.
- For mutant selection, prepare a plating mixture containing the cells, culture medium, and molten agar. Add TFT to this mixture.
- Plate the mixture into petri dishes.

- For viability, prepare a similar plating mixture without TFT and plate at a lower cell density.
- Allow the agar to solidify and incubate the plates at 37°C in a humidified incubator with 5% CO<sub>2</sub> for 10-14 days.

#### 5. Colony Counting and Data Analysis:

- Count the number of colonies on both the mutant selection and viability plates.
- Calculate the cloning efficiency and mutant frequency.
- Calculate the Relative Total Growth (RTG) to assess cytotoxicity.[10]
- Colony sizing (distinguishing between large and small colonies) can be performed to provide additional information on the nature of the mutagenic event.[3][6]

## Signaling Pathways and Experimental Workflows

The following diagrams illustrate key cellular signaling pathways involved in the response to DNA damage and provide a visual representation of the experimental workflow for the L5178Y mouse lymphoma assay.

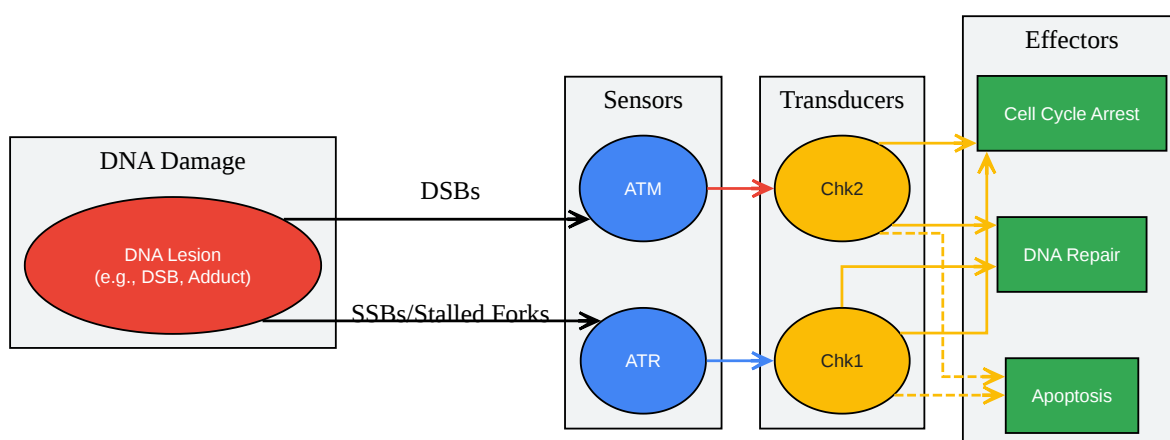

[Click to download full resolution via product page](#)

Figure 1: Simplified DNA Damage Response Pathway.

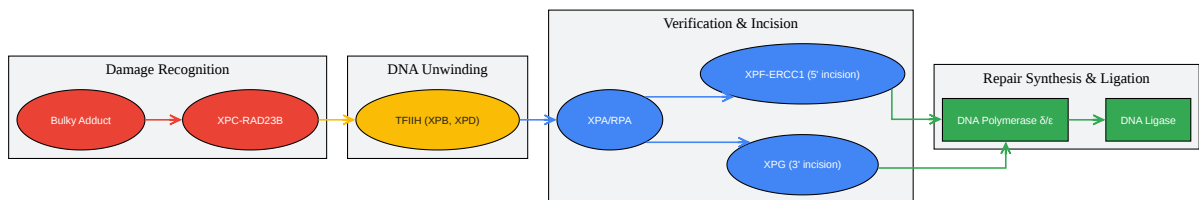

[Click to download full resolution via product page](#)

Figure 2: Nucleotide Excision Repair (NER) Pathway.

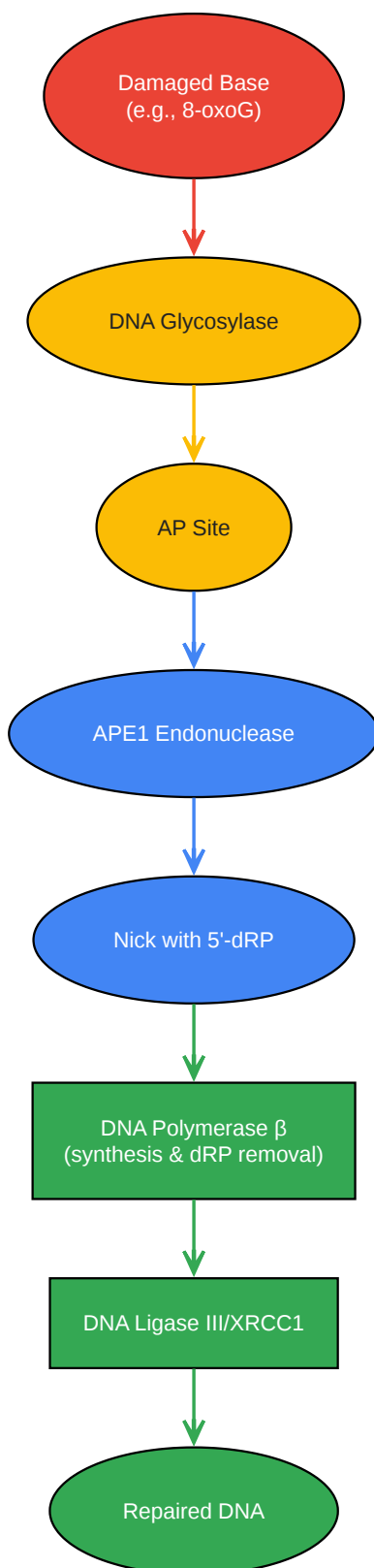

[Click to download full resolution via product page](#)

Figure 3: Base Excision Repair (BER) Pathway.

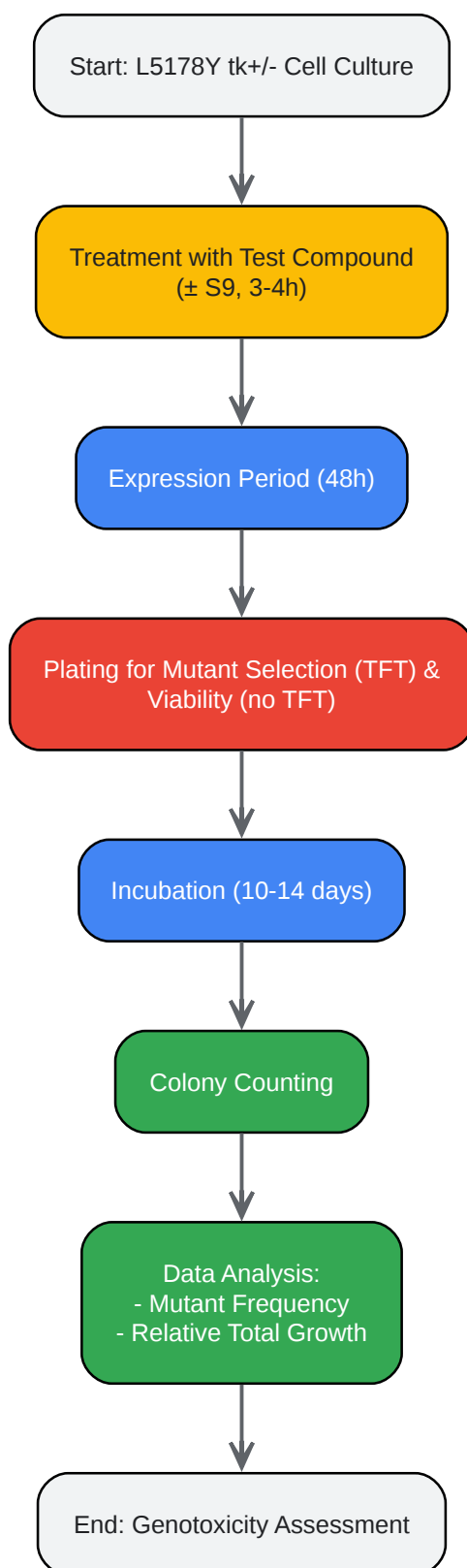

[Click to download full resolution via product page](#)

Figure 4: Experimental Workflow of the L5178Y Assay.

**Need Custom Synthesis?**

BenchChem offers custom synthesis for rare earth carbides and specific isotopic labeling.

Email: [info@benchchem.com](mailto:info@benchchem.com) or [Request Quote Online](#).

## References

- [1. academic.oup.com](https://academic.oup.com) [[academic.oup.com](https://academic.oup.com)]
- [2. geneglobe.qiagen.com](https://geneglobe.qiagen.com) [[geneglobe.qiagen.com](https://geneglobe.qiagen.com)]
- [3. researchgate.net](https://researchgate.net) [[researchgate.net](https://researchgate.net)]
- [4. researchgate.net](https://researchgate.net) [[researchgate.net](https://researchgate.net)]
- [5. experts.illu.edu](https://experts.illu.edu) [[experts.illu.edu](https://experts.illu.edu)]
- [6. researchgate.net](https://researchgate.net) [[researchgate.net](https://researchgate.net)]
- [7. DNA Damage Sensing by the ATM and ATR Kinases - PMC](https://pubmed.ncbi.nlm.nih.gov/311111111/) [[pmc.ncbi.nlm.nih.gov](https://pubmed.ncbi.nlm.nih.gov/311111111/)]
- [8. taglus.com](https://taglus.com) [[taglus.com](https://taglus.com)]
- [9. Base Excision Repair - PMC](https://pubmed.ncbi.nlm.nih.gov/311111111/) [[pmc.ncbi.nlm.nih.gov](https://pubmed.ncbi.nlm.nih.gov/311111111/)]
- [10. journals.biologists.com](https://journals.biologists.com) [[journals.biologists.com](https://journals.biologists.com)]
- To cite this document: BenchChem. [Application Notes and Protocols for the L5178Y Mouse Lymphoma Assay (MLA)]. BenchChem, [2026]. [Online PDF]. Available at: [<https://www.benchchem.com/product/b12376010/docs#application-notes-and-protocols-for-the-l5178y-mouse-lymphoma-assay-mla>]

---

**Disclaimer & Data Validity:**

The information provided in this document is for Research Use Only (RUO) and is strictly not intended for diagnostic or therapeutic procedures. While BenchChem strives to provide accurate protocols, we make no warranties, express or implied, regarding the fitness of this product for every specific experimental setup.

**Technical Support:** The protocols provided are for reference purposes. Unsure if this reagent suits your experiment?

**Need Industrial/Bulk Grade?** [Request Custom Synthesis Quote](#)

# BenchChem

Our mission is to be the trusted global source of essential and advanced chemicals, empowering scientists and researchers to drive progress in science and industry.

## Contact

Address: 3281 E Guasti Rd

Ontario, CA 91761, United States

Phone: (601) 213-4426

Email: [info@benchchem.com](mailto:info@benchchem.com)

[Contact our Ph.D. Support Team for a compatibility check](#)