

Technical Support Center: TDP-43-IN-2 Cytotoxicity Assessment in Neuronal Cells

Author: BenchChem Technical Support Team. **Date:** April 2026

Compound of Interest

Compound Name: TDP-43-IN-2

Cat. No.: B12375579

[Get Quote](#)

This technical support center provides troubleshooting guidance and frequently asked questions for researchers assessing the cytotoxicity of **TDP-43-IN-2**, a novel investigational compound, in neuronal cell cultures.

Troubleshooting Guide

This guide addresses common issues that may arise during the experimental assessment of **TDP-43-IN-2** in neuronal cells.

Problem	Potential Cause	Suggested Solution
High background cell death in control (vehicle-treated) cultures.	<ol style="list-style-type: none">1. Suboptimal neuronal culture conditions: Poor initial health of primary neurons or cell lines.[1]2. Solvent toxicity: The vehicle (e.g., DMSO) concentration may be too high.3. Contamination: Bacterial or fungal contamination of cultures.[1]	<ol style="list-style-type: none">1. Optimize culture protocols: Review and refine neuron isolation, plating density, and maintenance procedures.[1]2. Perform a vehicle toxicity curve: Determine the maximum non-toxic concentration of the solvent.3. Implement aseptic techniques: Regularly check for and discard contaminated cultures.
Inconsistent results between replicate experiments.	<ol style="list-style-type: none">1. Variability in neuronal preparations: Differences in health and density of primary neuron preps.[1]2. Inconsistent compound treatment: Variations in incubation times or pipetting.[2]3. Plate edge effects: Evaporation in outer wells of multi-well plates.[1]	<ol style="list-style-type: none">1. Standardize protocols: Use a consistent protocol for neuronal isolation and culture.[1]2. Ensure consistent treatment: Use timers for incubations and careful, consistent pipetting techniques.[2]3. Minimize edge effects: Do not use the outer wells for experimental conditions; fill them with sterile PBS or media.
No observable cytotoxicity at expected concentrations.	<ol style="list-style-type: none">1. Compound instability: TDP-43-IN-2 may be unstable in culture medium.2. Incorrect concentration: Errors in calculation or dilution.3. Low cell sensitivity: The neuronal cell type used may be resistant to the compound's effects.	<ol style="list-style-type: none">1. Check compound stability: Consult the manufacturer's data sheet for stability information. Prepare fresh solutions for each experiment.2. Verify calculations and dilutions: Double-check all calculations and prepare fresh dilutions from a new stock.3. Use a positive control: Include

a known cytotoxic compound to confirm cell sensitivity. Consider using a more sensitive neuronal cell line or primary culture.

<p>Unexpected increase in TDP-43 aggregation.</p>	<p>1. Compound-induced stress: TDP-43-IN-2 may be inadvertently inducing cellular stress, promoting TDP-43 mislocalization and aggregation.[3][4] 2. Off-target effects: The compound may be interacting with other cellular pathways that regulate protein homeostasis.</p>	<p>1. Assess cellular stress markers: Measure markers of oxidative stress, ER stress, and the integrated stress response. 2. Perform target engagement studies: Confirm that TDP-43-IN-2 is interacting with its intended target.</p>
---	--	---

Frequently Asked Questions (FAQs)

Q1: What is the proposed mechanism of TDP-43 neurotoxicity?

A1: TDP-43 neurotoxicity is thought to occur through two main, non-mutually exclusive mechanisms: a "loss-of-function" of its normal nuclear roles and a "gain-of-function" from its toxic aggregation in the cytoplasm.[5][6] Under normal conditions, TDP-43 is predominantly located in the nucleus where it is involved in RNA metabolism.[7] In disease states, TDP-43 can be depleted from the nucleus and accumulate and aggregate in the cytoplasm.[8][9] These cytoplasmic aggregates are associated with cellular stress, mitochondrial dysfunction, and impaired protein degradation pathways.[5][10]

Q2: What are the key cellular pathways to monitor when assessing **TDP-43-IN-2** cytotoxicity?

A2: Key pathways to monitor include:

- Cellular Stress Pathways: The Endoplasmic Reticulum (ER) stress response, the Integrated Stress Response (ISR), and oxidative stress pathways are often activated by TDP-43 pathology.[3][10][11]

- Mitochondrial Function: TDP-43 aggregation can lead to mitochondrial dysfunction and increased oxidative stress.[5][10]
- Protein Degradation Pathways: Both the ubiquitin-proteasome system and autophagy are involved in the clearance of TDP-43 and can be impaired in TDP-43 proteinopathies.[9]
- Apoptosis Pathways: Ultimately, cytotoxic insults can lead to the activation of programmed cell death.

Q3: What neuronal cell models are appropriate for testing **TDP-43-IN-2**?

A3: The choice of cell model depends on the experimental goals.

- Primary Neuronal Cultures: These more closely resemble the in vivo environment but can have higher variability.[12]
- iPSC-derived Neurons: Human iPSC-derived neurons offer a relevant genetic background and can be used for patient-specific studies.[13]
- Neuronal Cell Lines (e.g., SH-SY5Y, Neuro-2a): These are easier to culture and provide more consistent results, making them suitable for initial high-throughput screening.[2][14]

Q4: What are the recommended methods for quantifying neuronal cytotoxicity?

A4: A combination of assays is recommended for a comprehensive assessment:

- Metabolic Assays (e.g., MTT, MTS): These measure metabolic activity as an indicator of cell viability.[13][14]
- Membrane Integrity Assays (e.g., LDH release, Trypan Blue): These assays quantify cell death by measuring the release of intracellular components or the uptake of a dye by non-viable cells.[1][15]
- Apoptosis Assays (e.g., Caspase-3/7 activity, Annexin V staining): These specifically measure markers of programmed cell death.[14]

Experimental Protocols

Protocol 1: General Neuronal Cytotoxicity Assay

- **Cell Plating:** Plate neuronal cells in a 96-well plate at a predetermined optimal density.^[2] Allow cells to adhere and differentiate for the appropriate time.
- **Compound Preparation:** Prepare a dilution series of **TDP-43-IN-2** and a vehicle control in culture medium.
- **Cell Treatment:** Remove the existing medium from the cells and add the medium containing the different concentrations of **TDP-43-IN-2** or vehicle.
- **Incubation:** Incubate the plate for the desired time period (e.g., 24, 48, or 72 hours) in a humidified incubator.
- **Viability Assessment:** Perform a cytotoxicity assay, such as the MTT or LDH release assay, according to the manufacturer's instructions.^[2]^[15]
- **Data Analysis:** Calculate the percentage of cell viability relative to the vehicle-treated control cells.

Protocol 2: Immunofluorescence Staining for TDP-43 Localization

- **Cell Culture:** Grow neuronal cells on coverslips in a multi-well plate and treat with **TDP-43-IN-2** or vehicle as described above.
- **Fixation and Permeabilization:** After treatment, fix the cells with 4% paraformaldehyde, followed by permeabilization with a detergent solution (e.g., 0.1% Triton X-100).
- **Blocking and Antibody Incubation:** Block non-specific binding with a blocking buffer (e.g., PBS with 1% FBS). Incubate with a primary antibody against TDP-43.^[16]
- **Secondary Antibody and Counterstaining:** Wash and incubate with a fluorescently labeled secondary antibody. Counterstain the nuclei with DAPI.
- **Imaging:** Mount the coverslips on microscope slides and acquire images using a fluorescence microscope.

- Analysis: Quantify the nuclear and cytoplasmic fluorescence intensity of TDP-43 to assess its subcellular localization.

Visualizations

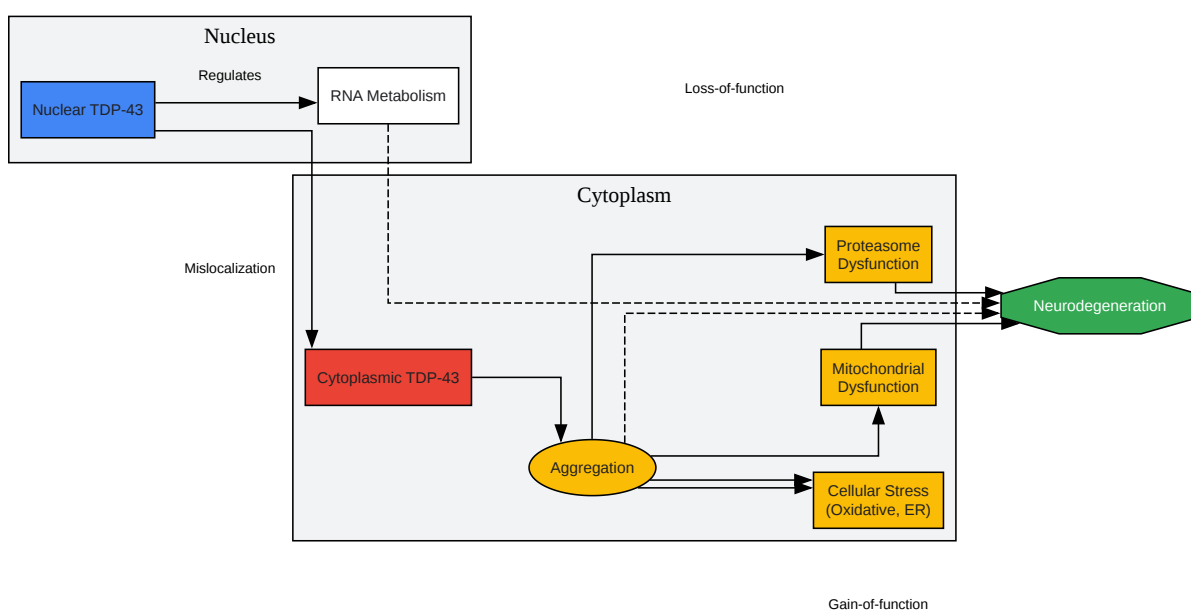

[Click to download full resolution via product page](#)

Caption: Key signaling pathways in TDP-43 mediated neurodegeneration.

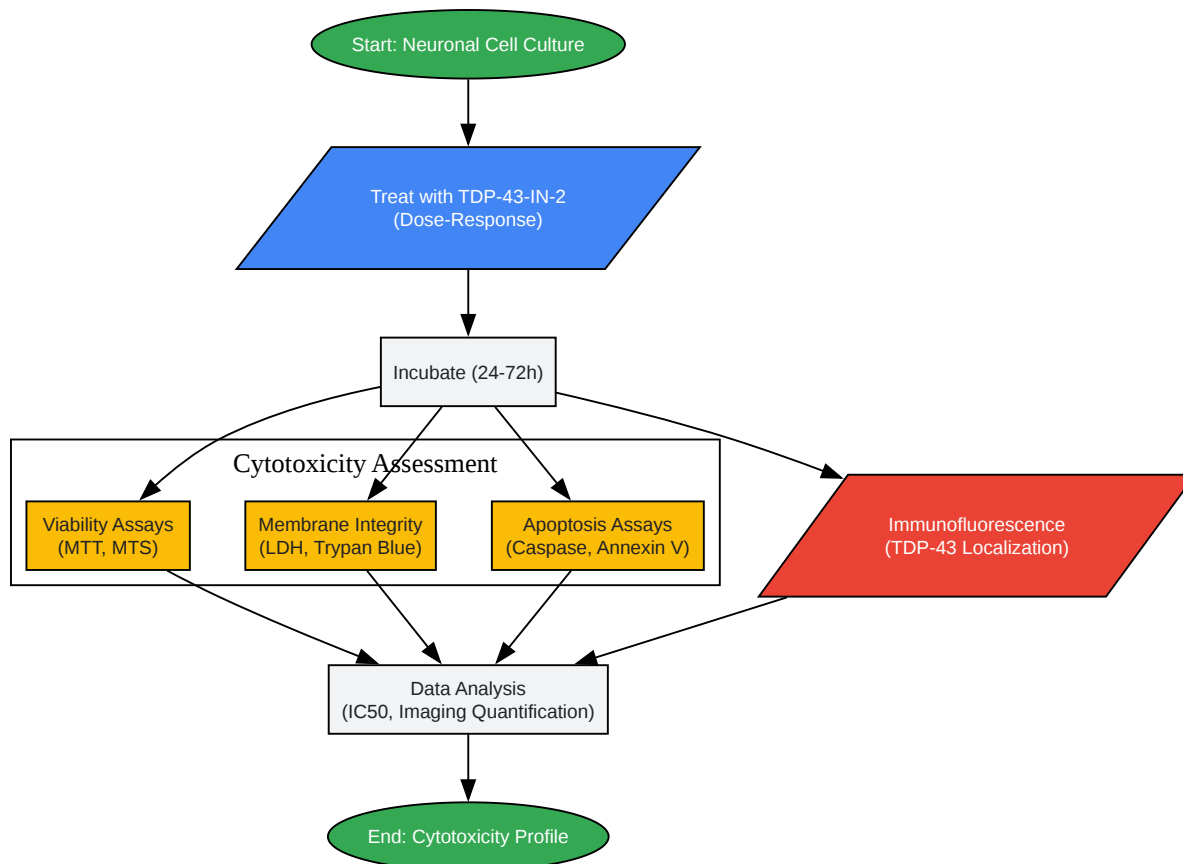

[Click to download full resolution via product page](#)

Caption: Experimental workflow for assessing **TDP-43-IN-2** cytotoxicity.

Need Custom Synthesis?

BenchChem offers custom synthesis for rare earth carbides and specific isotopic labeling.

Email: info@benchchem.com or [Request Quote Online](#).

References

- [1. benchchem.com \[benchchem.com\]](https://www.benchchem.com)
- [2. Cytotoxicity Assay Protocol & Troubleshooting - Creative Biolabs \[creativebiolabs.net\]](https://www.creativebiolabs.net)
- [3. Early activation of cellular stress and death pathways caused by cytoplasmic TDP-43 in the rNLS8 mouse model of ALS and FTD - PMC \[pmc.ncbi.nlm.nih.gov\]](https://pubmed.ncbi.nlm.nih.gov/16111111/)
- [4. TDP-43 Aggregation In Neurodegeneration: Are Stress Granules The Key? - PMC \[pmc.ncbi.nlm.nih.gov\]](https://pubmed.ncbi.nlm.nih.gov/16111111/)
- [5. jnnp.bmj.com \[jnnp.bmj.com\]](https://www.jnnp.bmj.com)
- [6. Review: transactive response DNA-binding protein 43 \(TDP-43\): mechanisms of neurodegeneration - PubMed \[pubmed.ncbi.nlm.nih.gov\]](https://pubmed.ncbi.nlm.nih.gov/16111111/)
- [7. Mechanisms Associated with TDP-43 Neurotoxicity in ALS/FTLD - PubMed \[pubmed.ncbi.nlm.nih.gov\]](https://pubmed.ncbi.nlm.nih.gov/16111111/)
- [8. Pathological mechanisms underlying TDP-43 driven neurodegeneration in FTLD–ALS spectrum disorders - PMC \[pmc.ncbi.nlm.nih.gov\]](https://pubmed.ncbi.nlm.nih.gov/16111111/)
- [9. Mechanisms underlying TDP-43 pathology and neurodegeneration: An updated Mini-Review - PMC \[pmc.ncbi.nlm.nih.gov\]](https://pubmed.ncbi.nlm.nih.gov/16111111/)
- [10. TDP-43 aggregation induced by oxidative stress causes global mitochondrial imbalance in ALS - PubMed \[pubmed.ncbi.nlm.nih.gov\]](https://pubmed.ncbi.nlm.nih.gov/16111111/)
- [11. \[PDF\] ALS-Associated TDP-43 Induces Endoplasmic Reticulum Stress, Which Drives Cytoplasmic TDP-43 Accumulation and Stress Granule Formation | Semantic Scholar \[semanticscholar.org\]](https://www.semanticscholar.org/paper/ALS-Associated-TDP-43-Induces-Endoplasmic-Reticulum-Stress-Which-Drives-Cytoplasmic-TDP-43-Accumulation-and-Stress-Granule-Formation/16111111)
- [12. Plate reader-based assays for measuring cell viability, neuroprotection and calcium in primary neuronal cultures - PMC \[pmc.ncbi.nlm.nih.gov\]](https://pubmed.ncbi.nlm.nih.gov/16111111/)
- [13. Comparative Neurotoxicity Screening in Human iPSC-derived Neural Stem Cells, Neurons and Astrocytes - PMC \[pmc.ncbi.nlm.nih.gov\]](https://pubmed.ncbi.nlm.nih.gov/16111111/)
- [14. TDP-43 Depletion Induces Neuronal Cell Damage through Dysregulation of Rho Family GTPases - PMC \[pmc.ncbi.nlm.nih.gov\]](https://pubmed.ncbi.nlm.nih.gov/16111111/)
- [15. Validation of a structure-function assay for neurotoxicity in primary and hiPSC-derived neurons | Axion Biosystems \[axionbiosystems.com\]](https://www.axionbiosystems.com)
- [16. A quantitative biology approach correlates neuronal toxicity with the largest inclusions of TDP-43 - PMC \[pmc.ncbi.nlm.nih.gov\]](https://pubmed.ncbi.nlm.nih.gov/16111111/)
- To cite this document: BenchChem. [Technical Support Center: TDP-43-IN-2 Cytotoxicity Assessment in Neuronal Cells]. BenchChem, [2026]. [Online PDF]. Available at: [\[https://www.benchchem.com/product/b12375579/docs#technical-support-center-tdp-43-in-2-cytotoxicity-assessment-in-neuronal-cells\]](https://www.benchchem.com/product/b12375579/docs#technical-support-center-tdp-43-in-2-cytotoxicity-assessment-in-neuronal-cells)

Disclaimer & Data Validity:

The information provided in this document is for Research Use Only (RUO) and is strictly not intended for diagnostic or therapeutic procedures. While BenchChem strives to provide accurate protocols, we make no warranties, express or implied, regarding the fitness of this product for every specific experimental setup.

Technical Support: The protocols provided are for reference purposes. Unsure if this reagent suits your experiment?

Need Industrial/Bulk Grade? [Request Custom Synthesis Quote](#)

BenchChem

Our mission is to be the trusted global source of essential and advanced chemicals, empowering scientists and researchers to drive progress in science and industry.

Contact

Address: 3281 E Guasti Rd
Ontario, CA 91761, United States
Phone: (601) 213-4426
Email: info@benchchem.com

[Contact our Ph.D. Support Team for a compatibility check](#)