

Primary vs. secondary T-cell response to NP (366-374)

Author: BenchChem Technical Support Team. **Date:** April 2026

Compound of Interest

Compound Name: *Influenza A NP (366-374)*

Cat. No.: *B12375292*

[Get Quote](#)

Core Concepts: Primary vs. Secondary T-Cell Response

The immune system's response to a pathogen it has not previously encountered is termed a primary response. This initial engagement is characterized by the activation of naive T-cells, which then undergo clonal expansion and differentiation into effector and memory cells. Upon subsequent encounters with the same pathogen, the memory T-cells orchestrate a secondary response, which is typically more rapid, of greater magnitude, and more effective at clearing the infection. The NP(366-374) epitope is a key target for CD8+ T-cells in the context of influenza infection in C57BL/6 mice and serves as an excellent model for studying these immunological dynamics.

Quantitative Analysis of T-Cell Responses

The magnitude and kinetics of NP(366-374)-specific CD8+ T-cell responses differ significantly between primary and secondary infections. The following tables summarize key quantitative data extracted from murine studies.

Table 1: Kinetics of NP(366-374)-Specific CD8+ T-Cell Response in the Lungs (Bronchoalveolar Lavage - BAL)

Response Type	Peak Response (Day Post-Infection)
Primary	Day 10
Secondary	Day 7-8

Data synthesized from studies showing earlier and significantly higher peak responses in the lungs during a secondary challenge.[\[1\]](#)

Table 2: Magnitude of NP(366-374)-Specific CD8+ T-Cell Response in the Spleen

Response Type	Peak Response (Day Post-Infection)
Primary	Day 10
Secondary	Day 7-8

This table reflects the substantial, though comparatively less dramatic than in the BAL, increase in the splenic T-cell response during a secondary infection.[\[1\]](#)

Table 3: Immunodominance Hierarchy of CD8+ T-Cell Responses

Response Type	NP(366-374) Response
Primary	Co-dominant with PA(224-233)
Secondary	Dominant (80-90% of influenza-specific CD8+ T-cells)

During a primary influenza virus infection, the CD8+ T-cell response is directed against both the NP(366–374) and the acid polymerase (PA(224–233)) epitopes in roughly equal numbers.[\[2\]\[3\]](#) However, in a secondary response, the NP(366–374)-specific T-cells dominate.[\[2\]\[3\]\[4\]](#) This shift is attributed to differential antigen presentation, where a broader range of cells, including

non-dendritic cells, can present the NP epitope to activate memory T-cells during a secondary infection.[2]

Phenotypic Characteristics

Primary and secondary NP(366-374)-specific T-cells also exhibit distinct phenotypic profiles.

Table 4: Phenotypic Markers of NP(366-374)-Specific CD8+ T-Cells

Cell Type	Key Markers
Naive (Pre-Primary)	CD44 ^{lo} , CD62L ^{hi}
Primary Effector	CD44 ^{hi} , CD62L ^{lo} , KLRG1 ^{hi}
Memory (Post-Primary)	CD44 ^{hi} , IL-7R α (^{hi})
Secondary Effector	CD44 ^{hi} , CD62L ^{lo} , High IFN- γ production

Experimental Protocols

Detailed methodologies for key experiments are provided below.

MHC Class I Tetramer Staining for Flow Cytometry

This protocol is for the identification and quantification of NP(366-374)-specific CD8+ T-cells.

Materials:

- Single-cell suspension from spleen, lymph nodes, or BAL.
- Phycoerythrin (PE)-labeled H-2Db NP(366-374) tetramer.
- Fluorochrome-conjugated antibodies (e.g., anti-CD8 α , anti-CD44).
- FACS buffer (PBS with 1% BSA and 0.1% sodium azide).
- Flow cytometer.

Procedure:

- Prepare a single-cell suspension of lymphocytes.
- Wash cells with FACS buffer.
- Stain with the PE-labeled DbNP366 tetramer for 60 minutes at room temperature in the dark.
[\[1\]](#)
- Wash the cells twice with FACS buffer.
- Incubate with fluorochrome-conjugated antibodies, such as anti-CD8 α , for 30 minutes on ice.
[\[1\]](#)[\[5\]](#)
- Wash the cells twice with FACS buffer.
- Resuspend the cells in FACS buffer for analysis.
- Acquire a minimum of 200,000 events on a flow cytometer.[\[2\]](#)
- Gate on CD8+ lymphocytes to determine the percentage of tetramer-positive cells.

Intracellular Cytokine Staining (ICS)

This assay measures the production of cytokines, such as IFN- γ , by NP(366-374)-specific T-cells upon stimulation.

Materials:

- Single-cell suspension.
- NP(366-374) peptide (ASNENMETM).
- Protein transport inhibitors (e.g., Brefeldin A or Monensin).
- Surface staining antibodies (e.g., anti-CD8 α).
- Fixation/Permeabilization buffer.

- Intracellular staining antibodies (e.g., anti-IFN- γ).
- Flow cytometer.

Procedure:

- Stimulate $1-2 \times 10^6$ cells with the NP(366-374) peptide for 4-6 hours at 37°C.[6][7]
- Add a protein transport inhibitor (e.g., Brefeldin A) for the duration of the stimulation to block cytokine secretion.[6][8]
- Wash the cells and perform surface staining with antibodies like anti-CD8 α .
- Fix and permeabilize the cells using a commercial fixation/permeabilization kit.[6][9]
- Perform intracellular staining with a fluorochrome-conjugated anti-IFN- γ antibody for 30-60 minutes at room temperature in the dark.[7][8]
- Wash the cells and resuspend them in FACS buffer.
- Analyze the samples on a flow cytometer, gating on CD8+ T-cells to identify the frequency of IFN- γ producing cells.

Enzyme-Linked Immunospot (ELISpot) Assay

The ELISpot assay is a highly sensitive method to quantify the number of cytokine-secreting cells.

Materials:

- PVDF-membrane 96-well plates pre-coated with anti-IFN- γ capture antibody.
- Single-cell suspension (PBMCs or splenocytes).
- NP(366-374) peptide.
- Biotinylated anti-IFN- γ detection antibody.
- Streptavidin-alkaline phosphatase (ALP).

- Substrate (e.g., BCIP/NBT).
- ELISpot reader.

Procedure:

- Pre-wet the antibody-coated 96-well plate.
- Add 200,000-300,000 cells per well.[\[10\]](#)
- Stimulate the cells with the NP(366-374) peptide for 18-20 hours at 37°C.[\[10\]](#)
- Wash the plates to remove cells, leaving behind the secreted cytokines bound to the capture antibody.
- Add the biotinylated detection antibody and incubate.
- Wash the plates and add streptavidin-ALP.
- Wash again and add the substrate to develop colored spots.
- Count the spots using an automated ELISpot reader. Each spot represents a single cytokine-producing cell.

Visualizing Key Pathways and Workflows

The following diagrams, generated using the DOT language, illustrate critical signaling pathways and experimental workflows.

T-Cell Activation Signaling Pathway

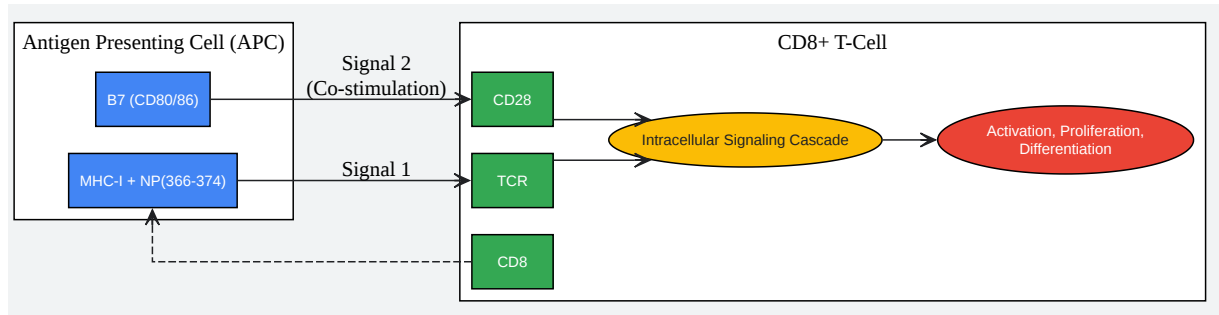

[Click to download full resolution via product page](#)

Caption: Simplified signaling pathway for CD8+ T-cell activation.

Experimental Workflow for Tetramer Staining

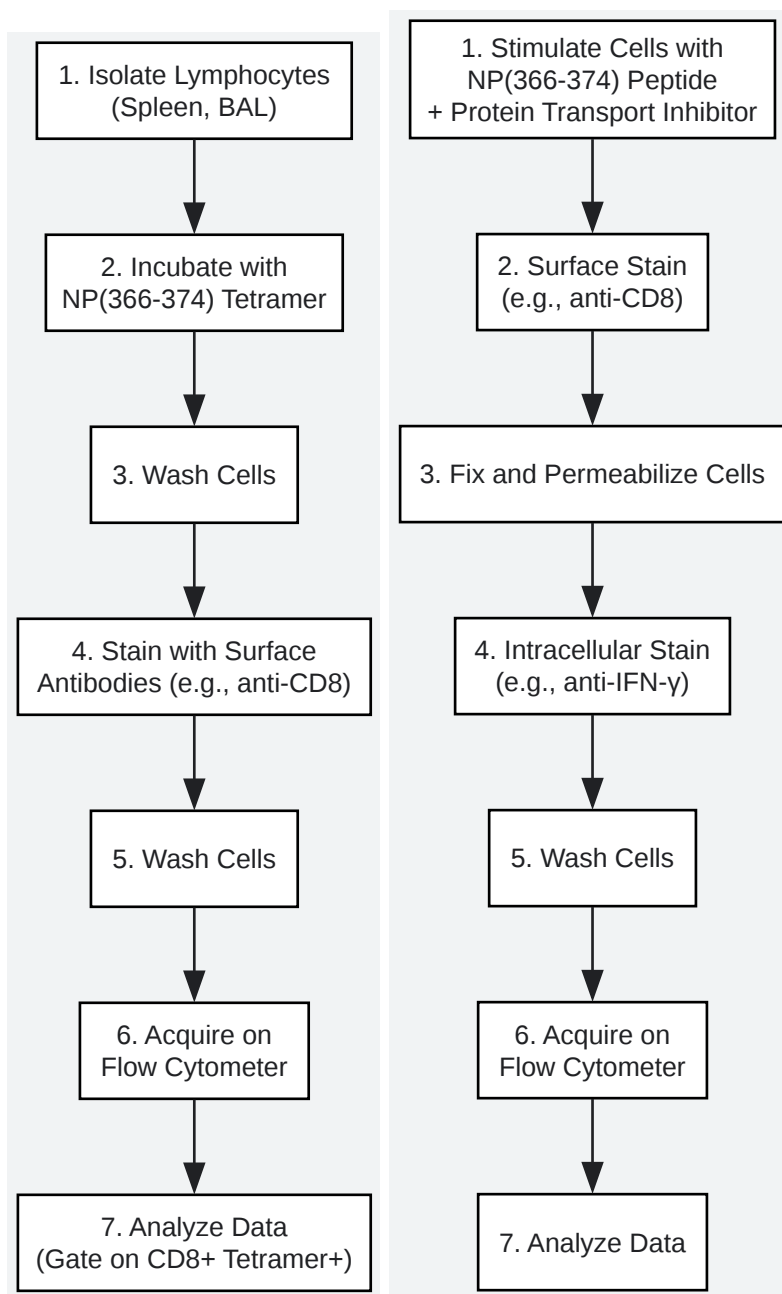

[Click to download full resolution via product page](#)

Need Custom Synthesis?

BenchChem offers custom synthesis for rare earth carbides and specific isotopic labeling.

Email: info@benchchem.com or [Request Quote Online](#).

References

- [1. pnas.org \[pnas.org\]](#)
- [2. rupress.org \[rupress.org\]](#)
- [3. A virus-specific CD8+ T cell immunodominance hierarchy determined by antigen dose and precursor frequencies - PMC \[pmc.ncbi.nlm.nih.gov\]](#)
- [4. journals.asm.org \[journals.asm.org\]](#)
- [5. pnas.org \[pnas.org\]](#)
- [6. Intracellular cytokine staining: How to get reliable data | Abcam \[abcam.com\]](#)
- [7. Limited Expansion of Virus-Specific CD8 T Cells in the Aged Environment - PMC \[pmc.ncbi.nlm.nih.gov\]](#)
- [8. Multiparameter Intracellular Cytokine Staining - PMC \[pmc.ncbi.nlm.nih.gov\]](#)
- [9.bdbiosciences.com \[bdbiosciences.com\]](#)
- [10. mdpi.com \[mdpi.com\]](#)
- [To cite this document: BenchChem. \[Primary vs. secondary T-cell response to NP \(366-374\)\]. BenchChem, \[2026\]. \[Online PDF\]. Available at: \[https://www.benchchem.com/product/b12375292/docs#primary-vs-secondary-t-cell-response-to-np-366-374\]](#)

Disclaimer & Data Validity:

The information provided in this document is for Research Use Only (RUO) and is strictly not intended for diagnostic or therapeutic procedures. While BenchChem strives to provide accurate protocols, we make no warranties, express or implied, regarding the fitness of this product for every specific experimental setup.

Technical Support: The protocols provided are for reference purposes. Unsure if this reagent suits your experiment?

Need Industrial/Bulk Grade? [Request Custom Synthesis Quote](#)

BenchChem

Our mission is to be the trusted global source of essential and advanced chemicals, empowering scientists and researchers to drive progress in science and industry.

Contact

Address: 3281 E Guasti Rd

Ontario, CA 91761, United States

Phone: (601) 213-4426

Email: info@benchchem.com

[Contact our Ph.D. Support Team for a compatibility check](#)