

# Preventing ASP6918 degradation in solution

**Author:** BenchChem Technical Support Team. **Date:** April 2026

## Compound of Interest

Compound Name: ASP6918  
Cat. No.: B12375681

[Get Quote](#)

## Technical Support Center: ASP6918

This technical support center provides guidance on the proper handling and storage of **ASP6918** in solution to prevent degradation and ensure experimental reproducibility. The information is intended for researchers, scientists, and drug development professionals.

## Frequently Asked Questions (FAQs)

Q1: What is the recommended solvent for preparing **ASP6918** stock solutions?

A1: For initial stock solutions, dimethyl sulfoxide (DMSO) is commonly used for organic molecules like **ASP6918**.<sup>[1]</sup> It is crucial to use anhydrous, high-purity DMSO, as the solvent is hygroscopic and absorbed water can contribute to compound degradation.<sup>[2]</sup>

Q2: How should I store **ASP6918** as a solid and in solution?

A2: As a solid, **ASP6918** should be stored at -20°C for long-term stability.<sup>[3]</sup> Once dissolved in a solvent like DMSO, stock solutions should be aliquoted into single-use volumes to avoid repeated freeze-thaw cycles and stored at -80°C for up to six months or -20°C for up to one month.<sup>[3]</sup>

Q3: Is **ASP6918** sensitive to light?

A3: While specific photostability data for **ASP6918** is not publicly available, its quinazoline core structure may be susceptible to photodegradation.[4][5] Therefore, it is recommended to protect solutions of **ASP6918** from light by using amber vials or by wrapping containers in foil.[5]

Q4: What are the potential degradation pathways for **ASP6918** in solution?

A4: **ASP6918** contains a quinazoline ring and an acrylamide moiety, which can be susceptible to degradation. The quinazoline ring can undergo hydrolysis under harsh acidic or basic conditions, especially with heating.[6] The acrylamide "warhead" is an electrophilic group that, while essential for its covalent binding to KRAS G12C, can also be prone to hydrolysis.[7] Additionally, the target cysteine (C12) on KRAS G12C can become oxidized in solution, which would prevent the covalent binding of **ASP6918**.

## Troubleshooting Guides

Issue 1: Loss of **ASP6918** activity in my experiments.

Possible Cause	Troubleshooting Steps
Degradation of stock solution	- Prepare a fresh stock solution from solid ASP6918. - Ensure you are using anhydrous DMSO.[2] - Verify that stock solutions have been stored properly at -80°C in single-use aliquots.[3]
Hydrolysis of the acrylamide moiety	- Avoid preparing working solutions in highly acidic or basic aqueous buffers for extended periods. - Prepare fresh working dilutions from the DMSO stock immediately before each experiment.
Oxidation of the target KRAS G12C protein	- Consider degassing buffers to remove dissolved oxygen. - Minimize the exposure of the protein solution to air.
Photodegradation	- Protect all solutions containing ASP6918 from light during preparation, storage, and experimentation.[5]

Issue 2: Precipitation of **ASP6918** in aqueous media.

Possible Cause	Troubleshooting Steps
Poor aqueous solubility	- When diluting the DMSO stock solution into an aqueous buffer, add the DMSO stock to the buffer slowly while vortexing. - Ensure the final concentration of DMSO in the working solution is as low as possible (typically <1%) to avoid solvent-induced precipitation.[3]
Compound instability leading to insoluble degradants	- Follow the recommendations for preventing degradation outlined in "Issue 1".

## Stability Summary and Storage Recommendations

While specific quantitative stability data for **ASP6918** is not publicly available, the following recommendations are based on the chemical properties of its core structures and general best practices for covalent inhibitors.

Table 1: General Stability of **ASP6918**'s Chemical Moieties

Chemical Moiety	Potential Degradation Pathways	General Stability Notes
Quinazoline Ring	- Hydrolysis (at extreme pH and high temperatures)[6] - Photodegradation[4][5]	Generally stable under typical experimental conditions (cold, dilute acidic or alkaline solutions).[6]
Acrylamide Moiety	- Hydrolysis (acidic or basic conditions)[7] - Reaction with nucleophiles	The reactive nature of this group is essential for its mechanism of action but also makes it susceptible to degradation.

Table 2: Recommended Storage Conditions for **ASP6918**

Form	Solvent	Temperature	Duration	Additional Notes
Solid	N/A	-20°C	Up to 3 years[3]	Store in a desiccator to protect from moisture.
Stock Solution	Anhydrous DMSO	-80°C	Up to 6 months[3]	Aliquot into single-use volumes to avoid freeze-thaw cycles. Protect from light.
Stock Solution	Anhydrous DMSO	-20°C	Up to 1 month[3]	Aliquot into single-use volumes. Protect from light.
Working Solution	Aqueous Buffer	Room Temperature or 37°C	Prepare fresh for each experiment	Minimize time in aqueous solution before use.

## Experimental Protocols

### Protocol 1: Preparation of **ASP6918** Stock Solution

- Allow the vial of solid **ASP6918** to equilibrate to room temperature before opening to prevent condensation of moisture.
- Prepare a stock solution of desired concentration (e.g., 10 mM) by adding the appropriate volume of anhydrous DMSO.
- Vortex the solution until the compound is completely dissolved. Gentle warming (up to 37°C) or brief sonication can be used to aid dissolution if necessary.
- Aliquot the stock solution into single-use, light-protected vials (e.g., amber tubes).

- Store the aliquots at -80°C.

#### Protocol 2: General Protocol for Assessing **ASP6918** Stability in an Aqueous Buffer

This protocol provides a framework for researchers to determine the stability of **ASP6918** in their specific experimental buffer.

- Preparation of Samples:
  - Prepare a fresh working solution of **ASP6918** in the desired aqueous buffer at the final experimental concentration.
  - Prepare a control sample of the same concentration in anhydrous DMSO.
- Incubation:
  - Incubate the aqueous sample at the experimental temperature (e.g., 37°C).
  - Store the DMSO control at -20°C.
- Time Points:
  - At various time points (e.g., 0, 2, 4, 8, 24 hours), take an aliquot of the aqueous sample.
- Analysis:
  - Analyze the concentration of intact **ASP6918** in the aliquots using a suitable analytical method, such as High-Performance Liquid Chromatography (HPLC) or Liquid Chromatography-Mass Spectrometry (LC-MS).
  - Compare the peak area of **ASP6918** at each time point to the initial time point (t=0) and the DMSO control to determine the percentage of degradation.

## Visualizations

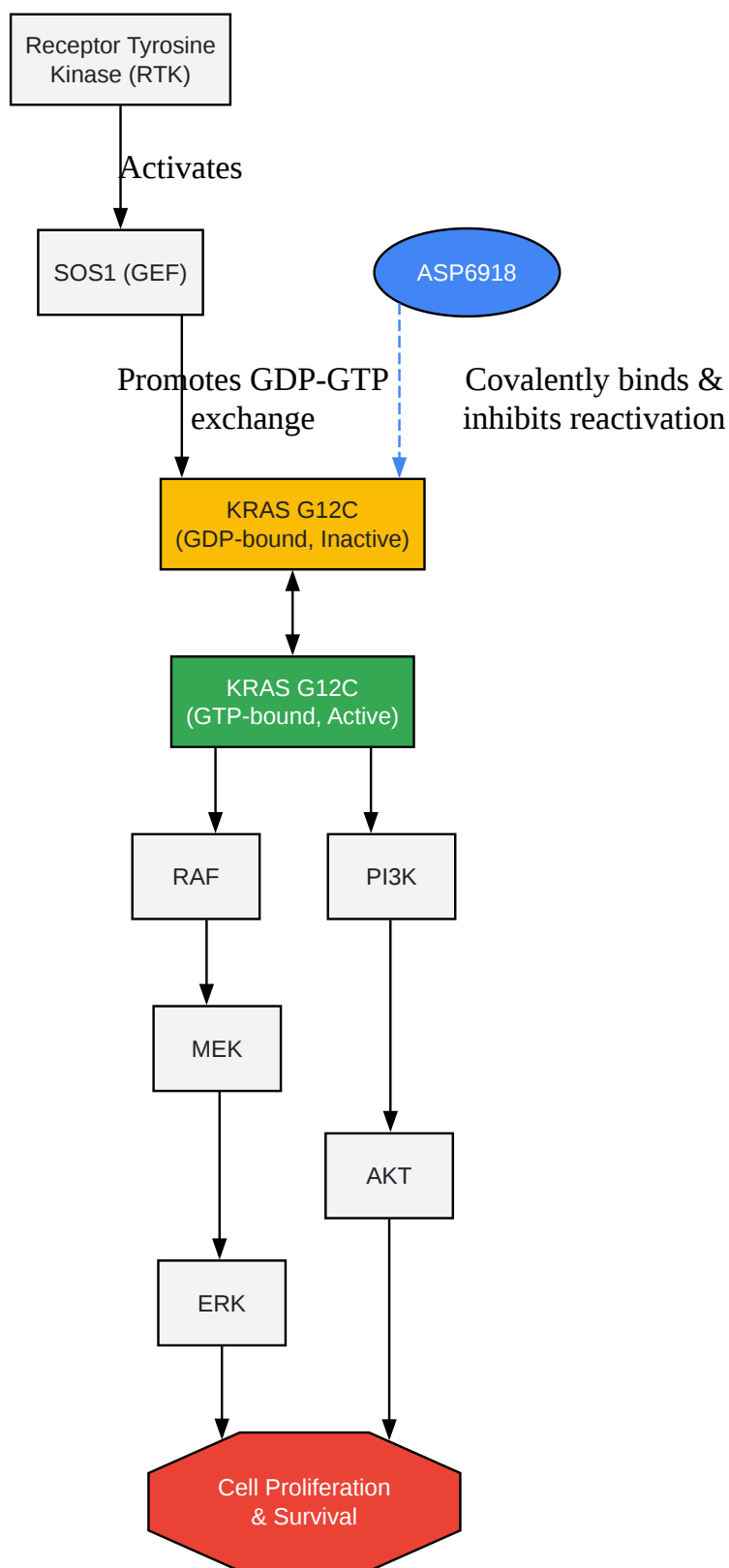

[Click to download full resolution via product page](#)

Caption: KRAS G12C signaling pathway and the inhibitory mechanism of **ASP6918**.<sup>[8][9][10]</sup>

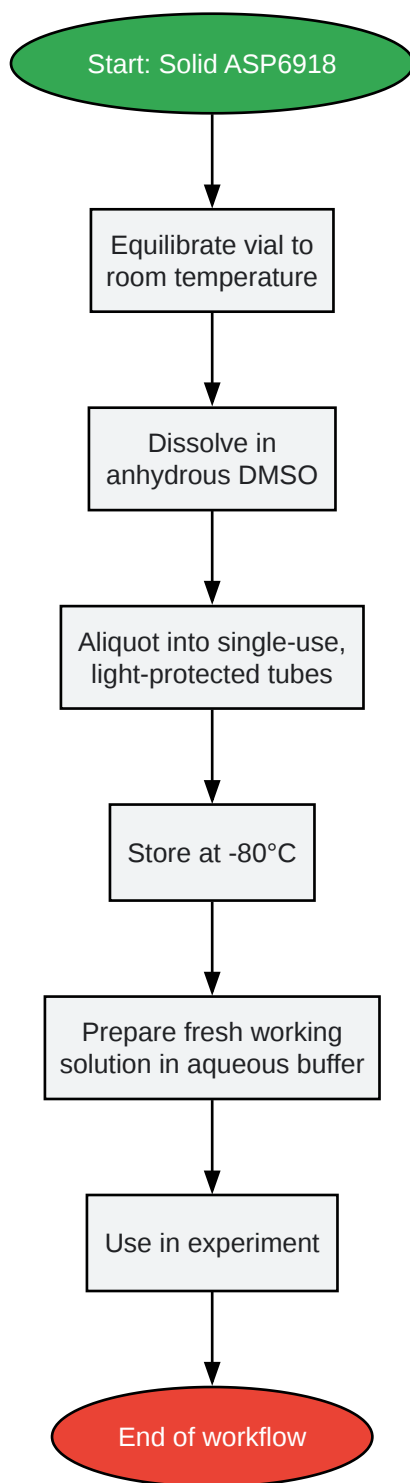

[Click to download full resolution via product page](#)

Caption: Recommended workflow for preparing and handling **ASP6918** solutions.[3]

### Need Custom Synthesis?

BenchChem offers custom synthesis for rare earth carbides and specific isotopic labeling.

Email: [info@benchchem.com](mailto:info@benchchem.com) or [Request Quote Online](#).

## References

- [1. researchgate.net \[researchgate.net\]](#)
- [2. pubs.acs.org \[pubs.acs.org\]](#)
- [3. An enzyme activity-based workflow for the identification and characterization of covalent inhibitors - PubMed \[pubmed.ncbi.nlm.nih.gov\]](#)
- [4. Photosensitization of TiO<sub>2</sub> microspheres by novel Quinazoline-derivative as visible-light-harvesting antenna for enhanced Rhodamine B photodegradation - PMC \[pmc.ncbi.nlm.nih.gov\]](#)
- [5. Quinazoline Derivatives Designed as Efflux Pump Inhibitors: Molecular Modeling and Spectroscopic Studies - PMC \[pmc.ncbi.nlm.nih.gov\]](#)
- [6. scispace.com \[scispace.com\]](#)
- [7. researchgate.net \[researchgate.net\]](#)
- [8. researchgate.net \[researchgate.net\]](#)
- [9. researchgate.net \[researchgate.net\]](#)
- [10. researchgate.net \[researchgate.net\]](#)
- To cite this document: BenchChem. [Preventing ASP6918 degradation in solution]. BenchChem, [2026]. [Online PDF]. Available at: [\[https://www.benchchem.com/product/b12375681/docs#preventing-asp6918-degradation-in-solution\]](https://www.benchchem.com/product/b12375681/docs#preventing-asp6918-degradation-in-solution)

---

### Disclaimer & Data Validity:

The information provided in this document is for Research Use Only (RUO) and is strictly not intended for diagnostic or therapeutic procedures. While BenchChem strives to provide accurate protocols, we make no warranties, express or implied, regarding the fitness of this product for every specific experimental setup.

**Technical Support:** The protocols provided are for reference purposes. Unsure if this reagent suits your experiment?

**Need Industrial/Bulk Grade?** [Request Custom Synthesis Quote](#)

## BenchChem

Our mission is to be the trusted global source of essential and advanced chemicals, empowering scientists and researchers to drive progress in science and industry.

### Contact

Address: 3281 E Guasti Rd  
Ontario, CA 91761, United States  
Phone: (601) 213-4426  
Email: [info@benchchem.com](mailto:info@benchchem.com)

[Contact our Ph.D. Support Team for a compatibility check](#)