

# Pharmacokinetics of ASP6918 in Animal Models: Application Notes and Protocols

**Author:** BenchChem Technical Support Team. **Date:** April 2026

## Compound of Interest

Compound Name: ASP6918

Cat. No.: B12375681

[Get Quote](#)

Disclaimer: As of November 2025, detailed quantitative pharmacokinetic data (including C<sub>max</sub>, T<sub>max</sub>, AUC, half-life, and bioavailability) for **ASP6918** in animal models is not publicly available in the reviewed scientific literature. The following application notes and protocols are based on the available information regarding its mechanism of action and in vivo efficacy studies, and will be updated as more specific data becomes accessible.

## Introduction

**ASP6918** is a potent and orally active covalent inhibitor of KRAS G12C, a mutated protein commonly found in various solid tumors. Preclinical studies have demonstrated its ability to induce dose-dependent tumor regression in xenograft mouse models, highlighting its potential as a targeted cancer therapeutic.[1] Understanding the pharmacokinetic profile of **ASP6918** is crucial for designing effective dosing regimens and translating preclinical findings to clinical settings. These application notes provide a framework for conducting and interpreting pharmacokinetic studies of **ASP6918** in animal models.

## Mechanism of Action: KRAS G12C Inhibition

**ASP6918** functions by irreversibly binding to the cysteine residue at position 12 of the mutated KRAS G12C protein. This covalent modification locks the KRAS protein in an inactive GDP-

bound state, thereby inhibiting downstream signaling pathways, such as the MAPK pathway, which are critical for tumor cell proliferation and survival.

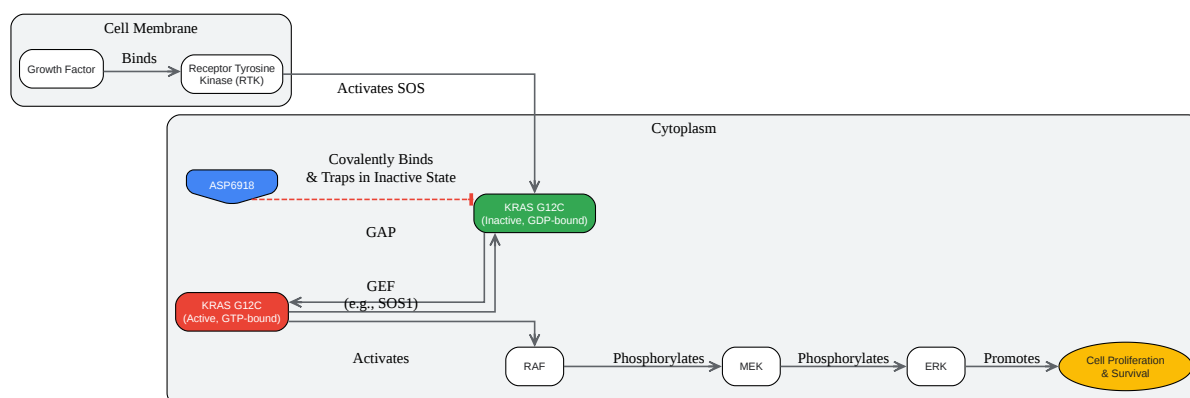

[Click to download full resolution via product page](#)

**Figure 1:** Simplified signaling pathway of KRAS G12C and the mechanism of action of ASP6918.

## In Vivo Efficacy Summary

While specific pharmacokinetic parameters are not available, in vivo studies have demonstrated the anti-tumor activity of **ASP6918** in an NCI-H1373 xenograft mouse model.

Dose (mg/kg, p.o.)	Dosing Schedule	Tumor Growth Inhibition (TGI)
10	Daily for 13 days	27%
20	Daily for 13 days	68%
40	Daily for 13 days	49%
60	Daily for 13 days	73%

Data from MedchemExpress, citing Imaizumi T, et al.[1]

This dose-dependent efficacy suggests that higher plasma and tumor concentrations of **ASP6918** lead to greater target engagement and anti-tumor response.

## Proposed Experimental Protocols for Pharmacokinetic Studies

The following protocols are suggested for characterizing the pharmacokinetic profile of **ASP6918** in rodent models.

### Single-Dose Pharmacokinetic Study in Mice

Objective: To determine the pharmacokinetic parameters of **ASP6918** after a single oral and intravenous administration.

Materials:

- **ASP6918**
- Vehicle for oral administration (e.g., 0.5% methylcellulose)
- Vehicle for intravenous administration (e.g., saline with a co-solvent like DMSO, if required)
- Male/Female CD-1 or BALB/c mice (6-8 weeks old)
- Blood collection supplies (e.g., EDTA-coated capillaries, microcentrifuge tubes)

- Analytical equipment (LC-MS/MS)

Protocol:

- Animal Acclimatization: Acclimatize animals for at least 7 days prior to the study.
- Dosing:
  - Oral (PO) Group: Administer **ASP6918** at a defined dose (e.g., 20 mg/kg) by oral gavage.
  - Intravenous (IV) Group: Administer **ASP6918** at a lower dose (e.g., 2 mg/kg) via tail vein injection.
- Blood Sampling: Collect blood samples (approximately 50  $\mu$ L) from the saphenous or tail vein at predetermined time points (e.g., 0, 0.25, 0.5, 1, 2, 4, 8, 12, and 24 hours post-dose).
- Plasma Preparation: Centrifuge blood samples to separate plasma. Store plasma at  $-80^{\circ}\text{C}$  until analysis.
- Bioanalysis: Quantify the concentration of **ASP6918** in plasma samples using a validated LC-MS/MS method.
- Data Analysis: Calculate pharmacokinetic parameters ( $C_{\text{max}}$ ,  $T_{\text{max}}$ , AUC,  $t_{1/2}$ , CL,  $V_d$ , and F) using non-compartmental analysis software.

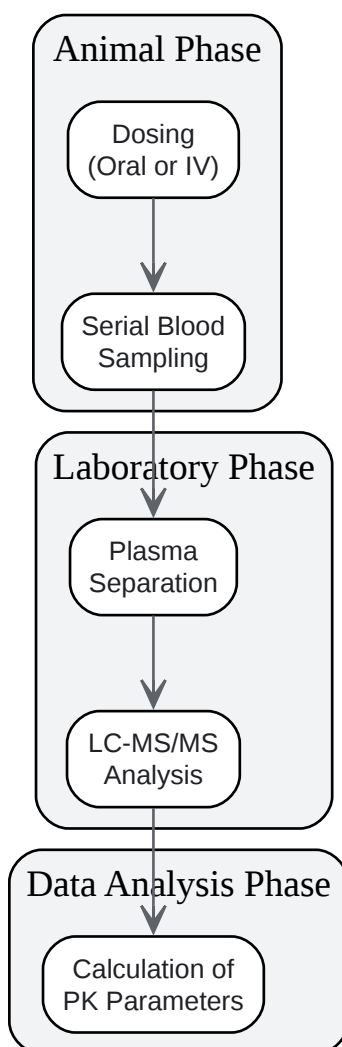

[Click to download full resolution via product page](#)

**Figure 2:** General workflow for a single-dose pharmacokinetic study.

## Tissue Distribution Study in Tumor-Bearing Mice

Objective: To determine the distribution of **ASP6918** in various tissues, including the tumor, after oral administration.

Materials:

- NCI-H1373 tumor-bearing nude mice.
- **ASP6918**

- Oral gavage supplies.
- Surgical tools for tissue collection.
- Homogenizer.
- Analytical equipment (LC-MS/MS).

#### Protocol:

- Tumor Implantation: Subcutaneously implant NCI-H1373 cells into the flank of nude mice. Allow tumors to reach a specified size.
- Dosing: Administer a single oral dose of **ASP6918** (e.g., 20 mg/kg).
- Tissue Collection: At various time points post-dose, euthanize cohorts of mice and collect tumor, brain, liver, kidney, and lung tissues.
- Tissue Homogenization: Homogenize the collected tissues.
- Bioanalysis: Extract **ASP6918** from the tissue homogenates and quantify its concentration using LC-MS/MS.
- Data Analysis: Determine the tissue-to-plasma concentration ratios at each time point.

## Data Interpretation and Application

The data generated from these studies will be instrumental for:

- Optimizing Dosing Regimens: Understanding the absorption, distribution, metabolism, and excretion (ADME) properties of **ASP6918** will inform the selection of optimal dosing schedules for sustained target engagement in efficacy studies.
- Pharmacokinetic/Pharmacodynamic (PK/PD) Modeling: Correlating drug exposure (AUC, Cmax) with pharmacodynamic markers (e.g., p-ERK inhibition in tumors) and anti-tumor efficacy will help in establishing a therapeutic window.

- Interspecies Scaling: Pharmacokinetic data from animal models can be used to predict human pharmacokinetics, aiding in the design of first-in-human clinical trials.

As more specific data on the pharmacokinetics of **ASP6918** becomes available, these application notes and protocols will be updated to provide more precise guidance for researchers in the field of oncology drug development.

#### Need Custom Synthesis?

BenchChem offers custom synthesis for rare earth carbides and specific isotopic labeling.

Email: [info@benchchem.com](mailto:info@benchchem.com) or [Request Quote Online](#).

## References

- [1. Discovery of ASP6918, a KRAS G12C inhibitor: Synthesis and structure-activity relationships of 1-{2,7-diazaspiro\[3.5\]non-2-yl}prop-2-en-1-one derivatives as covalent inhibitors with good potency and oral activity for the treatment of solid tumors - PubMed \[pubmed.ncbi.nlm.nih.gov\]](#)
- To cite this document: BenchChem. [Pharmacokinetics of ASP6918 in Animal Models: Application Notes and Protocols]. BenchChem, [2026]. [Online PDF]. Available at: [\[https://www.benchchem.com/product/b12375681/docs#pharmacokinetics-of-asp6918-in-animal-models-application-notes-and-protocols\]](https://www.benchchem.com/product/b12375681/docs#pharmacokinetics-of-asp6918-in-animal-models-application-notes-and-protocols)

---

#### Disclaimer & Data Validity:

The information provided in this document is for Research Use Only (RUO) and is strictly not intended for diagnostic or therapeutic procedures. While BenchChem strives to provide accurate protocols, we make no warranties, express or implied, regarding the fitness of this product for every specific experimental setup.

**Technical Support:** The protocols provided are for reference purposes. Unsure if this reagent suits your experiment?

**Need Industrial/Bulk Grade?** [Request Custom Synthesis Quote](#)

# BenchChem

Our mission is to be the trusted global source of essential and advanced chemicals, empowering scientists and researchers to drive progress in science and industry.

## Contact

Address: 3281 E Guasti Rd  
Ontario, CA 91761, United States  
Phone: (601) 213-4426  
Email: [info@benchchem.com](mailto:info@benchchem.com)

[Contact our Ph.D. Support Team for a compatibility check](#)