

Measuring Ternary Complex Cooperativity: A Comparative Guide to Fluorescence Polarization Assays

Author: BenchChem Technical Support Team. **Date:** April 2026

Compound of Interest

Compound Name: *PROTAC BRD4 Degradator-22*

Cat. No.: *B12374235*

[Get Quote](#)

For researchers, scientists, and drug development professionals, understanding the intricate dance of molecules in ternary complexes is paramount. The stability and formation of these three-part structures, often mediated by small molecules like PROTACs, are governed by a phenomenon known as cooperativity. Accurately quantifying this cooperativity is crucial for designing effective therapeutics and dissecting complex biological pathways. Fluorescence Polarization (FP) has emerged as a robust, solution-based technique to probe these interactions. This guide provides a comprehensive overview of FP assays for measuring ternary complex cooperativity, offering a comparison with alternative methods and detailed experimental protocols.

The Principle of Fluorescence Polarization in Assessing Molecular Interactions

Fluorescence Polarization (FP) is a powerful biophysical technique used to study molecular interactions in solution.^{[1][2]} The fundamental principle lies in monitoring the rotational motion of a fluorescently labeled molecule (a "tracer"). When a small fluorescent tracer is excited with plane-polarized light, it tumbles rapidly in solution during the fluorescence lifetime, resulting in

the emission of largely depolarized light. However, when this tracer binds to a much larger molecule, its rotational motion is significantly slowed. This slower tumbling leads to a higher degree of polarization in the emitted light. By measuring this change in polarization, the extent of binding between the tracer and its partner can be quantified.[2][3]

Application of FP to Ternary Complex Cooperativity

In the context of a ternary complex, which typically involves two proteins (e.g., a target protein and an E3 ligase) and a small molecule linker (e.g., a PROTAC), FP assays can be adapted to measure the cooperativity of complex formation.[4][5] Cooperativity (denoted by the factor α) quantifies how the binding of the first protein to the small molecule influences the binding of the second protein.

- Positive Cooperativity ($\alpha > 1$): The binding of the first protein enhances the affinity for the second protein, stabilizing the ternary complex.
- Negative Cooperativity ($\alpha < 1$): The binding of the first protein reduces the affinity for the second protein, destabilizing the ternary complex.
- No Cooperativity ($\alpha = 1$): The binding of the two proteins is independent of each other.

To measure cooperativity using FP, a competitive binding assay is often employed. In a typical setup, a fluorescently labeled tracer that binds to one of the proteins is used. The assay is performed in the presence and absence of the second protein, and the ability of the unlabeled small molecule (e.g., PROTAC) to displace the tracer is measured. The shift in the half-maximal inhibitory concentration (IC₅₀) or the dissociation constant (K_d) in the presence of the second protein reveals the cooperativity of the ternary complex formation.[6]

Experimental Workflow and Signaling Pathways

The general workflow for a fluorescence polarization-based assay to determine ternary complex cooperativity involves several key steps, from initial binary interaction assessments to the final cooperativity calculation.

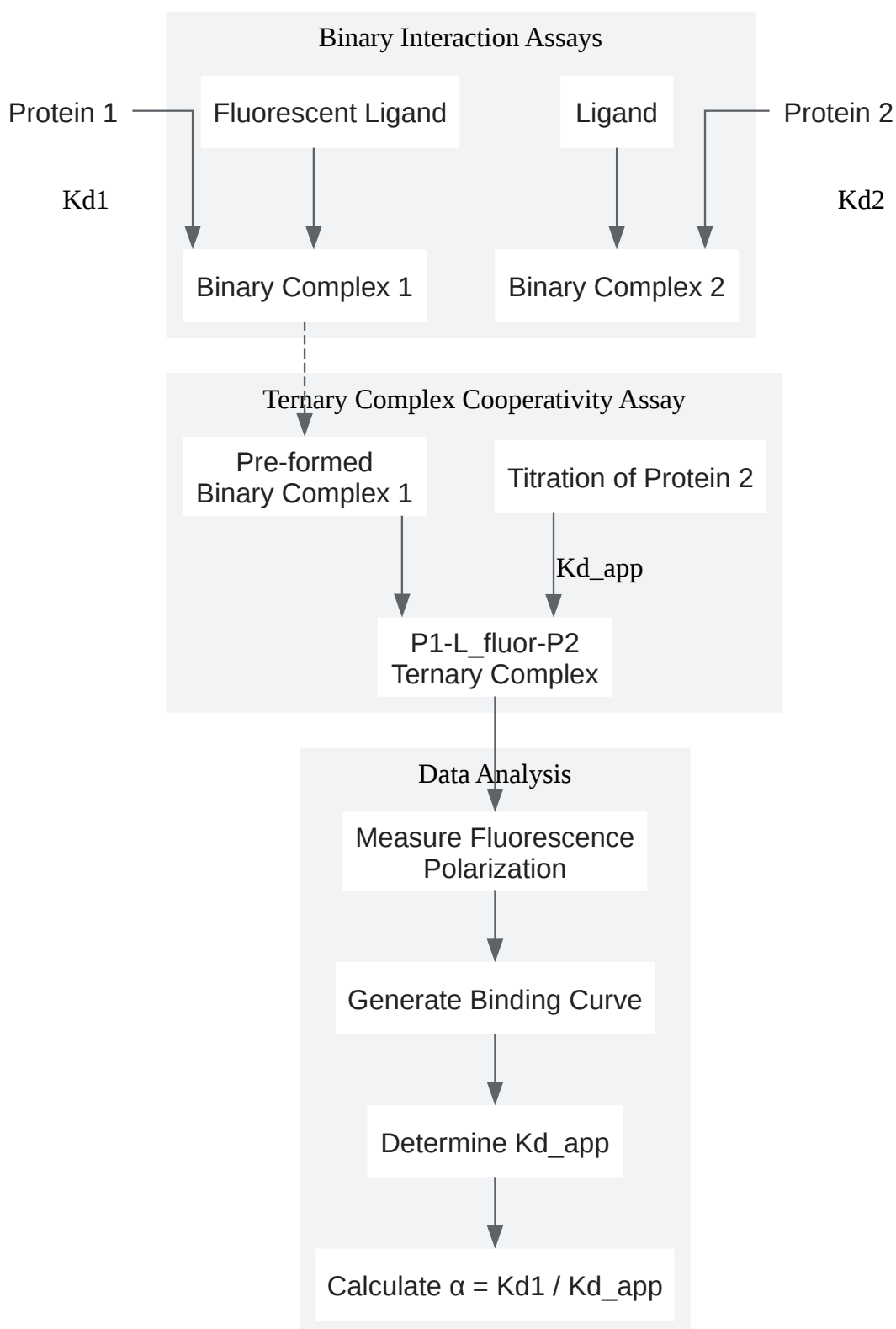

[Click to download full resolution via product page](#)

Figure 1. A flowchart illustrating the experimental workflow for determining ternary complex cooperativity using a fluorescence polarization assay.

The underlying principle of ternary complex formation and the concept of cooperativity can be visualized as a signaling pathway.

Figure 2. A diagram illustrating the formation of a ternary complex and the definition of cooperativity (α).

Quantitative Data Comparison

The following table summarizes hypothetical data from a fluorescence polarization experiment designed to measure the cooperativity of a PROTAC-mediated ternary complex between a target protein (TP) and an E3 ligase.

Assay Component	Description	Dissociation Constant (Kd)	Cooperativity (α)
Binary Interaction 1	Binding of fluorescently labeled PROTAC to Target Protein (TP)	100 nM	-
Binary Interaction 2	Binding of fluorescently labeled PROTAC to E3 Ligase	200 nM	-
Ternary Interaction (TP first)	Binding of E3 Ligase to pre-formed TP-PROTAC complex	20 nM	10
Ternary Interaction (E3 first)	Binding of TP to pre-formed E3-PROTAC complex	10 nM	10

Note: The cooperativity factor (α) is calculated as the ratio of the binary Kd to the apparent ternary Kd. For example, in the "Ternary Interaction (E3 first)" scenario, $\alpha = (\text{Binary Kd of PROTAC to TP}) / (\text{Apparent Kd of TP to E3-PROTAC complex}) = 100 \text{ nM} / 10 \text{ nM} = 10$. A

cooperativity factor of 10 indicates a strong positive cooperativity, meaning the formation of the binary complex significantly enhances the binding of the third component.

Detailed Experimental Protocol

This protocol outlines a typical fluorescence polarization competition assay to determine the cooperativity of a PROTAC that induces the formation of a ternary complex between a target protein and an E3 ligase.

Materials:

- Purified Target Protein (TP)
- Purified E3 Ligase
- PROTAC of interest
- Fluorescently labeled tracer (a small molecule or peptide that binds to the target protein with known affinity)
- Assay Buffer (e.g., PBS with 0.01% Tween-20 and 1 mM DTT)
- 384-well, low-volume, black, non-binding surface microplates
- A microplate reader capable of measuring fluorescence polarization

Procedure:

- Preparation of Reagents:
 - Prepare stock solutions of the target protein, E3 ligase, PROTAC, and fluorescent tracer in the assay buffer.
 - Perform serial dilutions of the PROTAC to create a concentration gradient for the competition assay.
- Binary Binding Affinity Determination (PROTAC vs. Tracer):

- To a series of wells, add a fixed concentration of the target protein and the fluorescent tracer.
- Add the serially diluted PROTAC to these wells.
- Incubate the plate at room temperature for a specified time (e.g., 60 minutes) to reach equilibrium.
- Measure the fluorescence polarization of each well.
- Plot the FP signal against the PROTAC concentration and fit the data to a suitable binding model to determine the IC50, which can be converted to a Ki or Kd value.
- Ternary Complex Cooperativity Measurement:
 - Prepare two sets of experiments:
 - Set A (Absence of E3 Ligase): Repeat the binary binding affinity experiment as described above.
 - Set B (Presence of E3 Ligase): To a series of wells, add a fixed concentration of the target protein, the fluorescent tracer, and a saturating concentration of the E3 ligase.
 - Add the serially diluted PROTAC to the wells of Set B.
 - Incubate the plates and measure the fluorescence polarization as before.
 - Plot the FP signal against the PROTAC concentration for both sets of experiments.
- Data Analysis and Cooperativity Calculation:
 - Determine the Kd of the PROTAC for the target protein in the absence (Kd_binary) and presence (Kd_ternary) of the E3 ligase from the respective binding curves.
 - Calculate the cooperativity factor (α) using the following formula: $\alpha = \frac{\text{Kd_binary}}{\text{Kd_ternary}}$

Comparison with Alternative Methods

While FP is a powerful technique, other methods can also be employed to study ternary complex formation and cooperativity.

Method	Principle	Advantages	Disadvantages
Fluorescence Polarization (FP)	Measures changes in the rotational speed of a fluorescent molecule upon binding.[7][8]	Homogeneous, solution-based, real-time measurements, relatively low cost.[9]	Requires a fluorescent label, sensitive to fluorescent artifacts, may have a limited dynamic range.
Time-Resolved Fluorescence Resonance Energy Transfer (TR-FRET)	Measures energy transfer between a donor and an acceptor fluorophore when in close proximity.	High sensitivity, low background, homogeneous assay format.	Requires dual labeling of interacting partners, potential for spectral overlap and interference.
AlphaLISA (Amplified Luminescent Proximity Homogeneous Assay)	Bead-based assay where singlet oxygen transfer between donor and acceptor beads in close proximity generates a luminescent signal.	High sensitivity, no-wash format, amenable to high-throughput screening.	Can be prone to interference from singlet oxygen quenchers, requires specific bead-conjugated reagents.
Isothermal Titration Calorimetry (ITC)	Directly measures the heat released or absorbed during a binding event.	Label-free, provides a complete thermodynamic profile of the interaction (K_d , ΔH , ΔS).	Requires large amounts of pure protein, lower throughput, sensitive to buffer mismatch.[5]
Surface Plasmon Resonance (SPR)	Detects changes in the refractive index at the surface of a sensor chip as molecules bind and dissociate.	Label-free, real-time kinetic data (k_{on} , k_{off}), high sensitivity.	Requires immobilization of one binding partner, which may affect its activity; can be expensive.[6]

Conclusion

Fluorescence polarization assays offer a robust and accessible method for the quantitative analysis of ternary complex cooperativity.[4] Its homogeneous, solution-based format makes it particularly well-suited for screening and characterizing small molecule-mediated protein-protein interactions. While alternative techniques each have their own strengths, the balance of simplicity, cost-effectiveness, and the rich quantitative data it provides makes FP a valuable tool in the arsenal of researchers in drug discovery and chemical biology. The detailed protocol and comparative overview provided in this guide aim to equip scientists with the necessary knowledge to effectively implement and interpret FP assays for the study of ternary complex dynamics.

Need Custom Synthesis?

BenchChem offers custom synthesis for rare earth carbides and specific isotopic labeling.

Email: info@benchchem.com or [Request Quote Online](#).

References

- [1. Estimating the cooperativity of PROTAC-induced ternary complexes using ¹⁹F NMR displacement assay - PMC \[pmc.ncbi.nlm.nih.gov\]](#)
- [2. Fluorescence Polarization \(FP\) | Molecular Devices \[moleculardevices.com\]](#)
- [3. Fluorescence Polarization \(FP\)—Note 1.4 | Thermo Fisher Scientific - HK \[thermofisher.com\]](#)
- [4. Fluorescence Polarization-based Measurement of Protein-Ligand Interaction in Fungal Cell Lysates - PMC \[pmc.ncbi.nlm.nih.gov\]](#)
- [5. Ternary complex formation - Profacgen \[profacgen.com\]](#)
- [6. SPR-Measured Dissociation Kinetics of PROTAC Ternary Complexes Influence Target Degradation Rate - PMC \[pmc.ncbi.nlm.nih.gov\]](#)
- [7. Mechanistic and Structural Features of PROTAC Ternary Complexes | Springer Nature Experiments \[experiments.springernature.com\]](#)
- [8. bpsbioscience.com \[bpsbioscience.com\]](#)
- [9. researchgate.net \[researchgate.net\]](#)

- To cite this document: BenchChem. [Measuring Ternary Complex Cooperativity: A Comparative Guide to Fluorescence Polarization Assays]. BenchChem, [2026]. [Online PDF]. Available at: [<https://www.benchchem.com/product/b12374235/docs#measuring-ternary-complex-cooperativity-a-comparative-guide-to-fluorescence-polarization-assays>]

Disclaimer & Data Validity:

The information provided in this document is for Research Use Only (RUO) and is strictly not intended for diagnostic or therapeutic procedures. While BenchChem strives to provide accurate protocols, we make no warranties, express or implied, regarding the fitness of this product for every specific experimental setup.

Technical Support: The protocols provided are for reference purposes. Unsure if this reagent suits your experiment?

Need Industrial/Bulk Grade? [Request Custom Synthesis Quote](#)

BenchChem

Our mission is to be the trusted global source of essential and advanced chemicals, empowering scientists and researchers to drive progress in science and industry.

Contact

Address: 3281 E Guasti Rd
Ontario, CA 91761, United States
Phone: (601) 213-4426
Email: info@benchchem.com

[Contact our Ph.D. Support Team for a compatibility check](#)