

Ensuring Reproducibility of TSP-1 Peptide Experiments: A Technical Support Guide

Author: BenchChem Technical Support Team. **Date:** April 2026

Compound of Interest

Compound Name: *Thrombospondin (TSP-1)-derived
CD36 binding motif*

Cat. No.: *B12374626*

[Get Quote](#)

This technical support center provides researchers, scientists, and drug development professionals with a comprehensive guide to ensure the reproducibility of experiments involving Thrombospondin-1 (TSP-1) peptides. This guide includes troubleshooting advice, frequently asked questions, detailed experimental protocols, and summaries of key quantitative data.

Frequently Asked Questions (FAQs) & Troubleshooting

This section addresses common issues and questions that may arise during the planning and execution of TSP-1 peptide experiments.

Question	Answer
1. How should I properly store and handle my TSP-1 peptide to ensure its stability and activity?	Lyophilized TSP-1 peptides should be stored at -20°C for long-term stability (up to 3 years) or at -80°C for extended periods.[1][2] Once reconstituted, stock solutions can be stored at -80°C for up to a year or at -20°C for shorter durations.[2] It is crucial to keep the peptide away from moisture.[1][2] For cell-based assays, if water is used as the solvent for the stock solution, it should be filtered and sterilized through a 0.22 µm filter before use.[1]
2. My TSP-1 peptide is not showing the expected anti-angiogenic or anti-tumor effect. What could be the issue?	Several factors could contribute to a lack of effect. First, verify the peptide's integrity and proper storage. Improper handling can lead to degradation. Second, ensure the correct peptide concentration is being used, as effects are dose-dependent.[3][4] Third, consider the specific cell line and experimental model, as cellular responses to TSP-1 can vary. Finally, confirm that the experimental timeline is sufficient to observe the desired outcome. For in vivo studies, the route of administration and dosing frequency are critical.[1]
3. What is the appropriate control for my TSP-1 peptide experiment?	The ideal control is a scrambled peptide with the same amino acid composition but a randomized sequence.[5] For instance, SLLK is used as a control peptide for the LSKL TSP-1 inhibitor.[2][6][7] This ensures that the observed effects are specific to the peptide's sequence and not due to non-specific peptide effects.
4. How do I choose the right concentration of TSP-1 peptide for my in vitro or in vivo experiment?	The optimal concentration depends on the specific peptide, the assay, and the cell type or animal model. For in vitro cell attachment or anti-proliferative assays, concentrations can range from micromolar (µM) levels.[1][8] For

example, a TSP-1-derived CD36 binding motif showed an IC50 of 80 μ M in an attachment assay.[1] For in vivo studies in murine models, dosages can be in the range of milligrams per kilogram (mg/kg), administered intraperitoneally every other day.[1] It is recommended to perform a dose-response curve to determine the optimal concentration for your specific experimental setup.

5. I am observing high background or non-specific binding in my receptor-binding assay. How can I troubleshoot this?

High background can be due to several factors. Ensure that non-specific binding is adequately blocked, for example, by using 1% BSA.[9] Verify the purity of your peptide, as impurities can cause non-specific interactions.[10] Additionally, optimizing the washing steps and the concentration of both the labeled ligand and the peptide can help reduce background noise.

Quantitative Data Summary

The following tables summarize key quantitative data from various TSP-1 peptide experiments to aid in experimental design and comparison.

Table 1: In Vitro Efficacy of TSP-1 Peptides

Peptide/Fragm ent	Assay	Cell Line	Concentration	Effect
TSP-1-derived CD36 binding motif	Cell Attachment	Retinoic acid-treated SK-N-SH	200 μ M	Complete inhibition of attachment to TSP-1 (IC50 = 80 μ M)[1]
TSP-1-derived CD36 binding motif	Platelet Aggregation	Activated Platelets	200 μ M	Partial inhibition of aggregation in response to various agonists[1]
TSP-1	Anti-Proliferation	C6 Glioma Cells	5 nM - 44 nM	Inhibition of proliferation[8]
Conjugated TSP-1 derived peptides	Anti-Proliferation	C6 Glioma Cells	0.63 - 2.5 μ M	Inhibition of proliferation[8]
Free TSP-1 derived peptides	Anti-Proliferation	C6 Glioma Cells	0.04 μ M - 50 μ M	Inhibition of proliferation[8]
TSP-1	Apoptosis	Granulosa Cells	10, 100, 1000 ng/ml	Dose-dependent promotion of apoptosis[3]
VR-13 (TSP-1-derived peptide)	Cell Migration	RF/6A Cells	10-100 μ g/mL	Concentration-dependent inhibition of migration[4]

Table 2: In Vivo Efficacy of TSP-1 Peptides

Peptide/Fragment	Animal Model	Dosage	Administration Route	Duration	Effect
TSP-1-derived CD36 binding motif	Murine model of human colon cancer (BALB/c nu/nu mice)	10 mg/kg	Intraperitoneal (i.p.)	Every other day for 4 weeks	69% reduction in primary tumor volume[1]
LSKL (TSP-1 inhibitor)	Akita mice (diabetic nephropathy model)	30 mg/kg	Intraperitoneal (i.p.)	Thrice weekly for 15 weeks	Significantly increased nephrin expression compared to saline or SLLK control[7]

Experimental Protocols

This section provides detailed methodologies for key experiments involving TSP-1 peptides.

Protocol 1: In Vitro Cell Proliferation Assay

This protocol is adapted from studies on the anti-proliferative effects of TSP-1 peptides on C6 glioma cells.[8]

Materials:

- C6 glioma cells
- DMEM containing 1% FBS
- 96-well tissue culture plates
- TSP-1 peptide and/or derived peptides (conjugated and free)
- Humidified incubator (37°C, 5% CO₂)

- Cell proliferation assay reagent (e.g., MTT, WST-1)
- Plate reader

Procedure:

- Seed C6 glioma cells in 96-well plates at a density of 5,000 cells/well (50,000 cells/ml) in 100 μ l of DMEM with 1% FBS.
- Prepare serial dilutions of the TSP-1 peptide or its derivatives. For full-length TSP-1, concentrations can range from 5 nM to 44 nM. For conjugated peptides, use concentrations from 0.63 to 2.5 μ M, and for free peptides, from 0.04 μ M to 50 μ M.[8]
- Add the prepared peptide solutions to the respective wells. Include a vehicle control (the solvent used to dissolve the peptide).
- Incubate the plates for 72 hours at 37°C in a humidified incubator with 5% CO₂.[8]
- After incubation, assess cell proliferation using a suitable colorimetric assay (e.g., MTT). Follow the manufacturer's instructions for the chosen reagent.
- Measure the absorbance at the appropriate wavelength using a plate reader.
- Calculate the percentage of proliferation inhibition relative to the vehicle control.

Protocol 2: Whole Blood Platelet Aggregation Assay

This protocol is based on the methodology used to assess the effect of the TAX2 peptide on platelet aggregation.[5]

Materials:

- Freshly drawn human whole blood collected in trisodium citrate tubes
- Multiplate analyzer (impedance aggregometry)
- 0.9% NaCl solution
- TAX2 peptide (or other TSP-1 peptide)

- Platelet agonists: Collagen (3.2 µg/mL), ADP (6.5 µmol/L), TRAP-6 (32 µmol/L)

Procedure:

- Dilute the whole blood 1:1 with 0.9% NaCl.
- Incubate the diluted blood with the TSP-1 peptide (e.g., TAX2 peptide at 100 to 800 µmol/L) for 3 minutes at 37°C.[5]
- Add a platelet agonist (collagen, ADP, or TRAP-6) to initiate aggregation.
- Record the aggregation curves for at least 6 minutes using the Multiplate analyzer.
- Express platelet aggregation as the area under the curve in arbitrary aggregation units over time.[5]
- Compare the results to a control condition, such as a scrambled peptide.

Signaling Pathways and Experimental Workflows

Visual representations of key biological processes and experimental designs can aid in understanding and reproducibility.

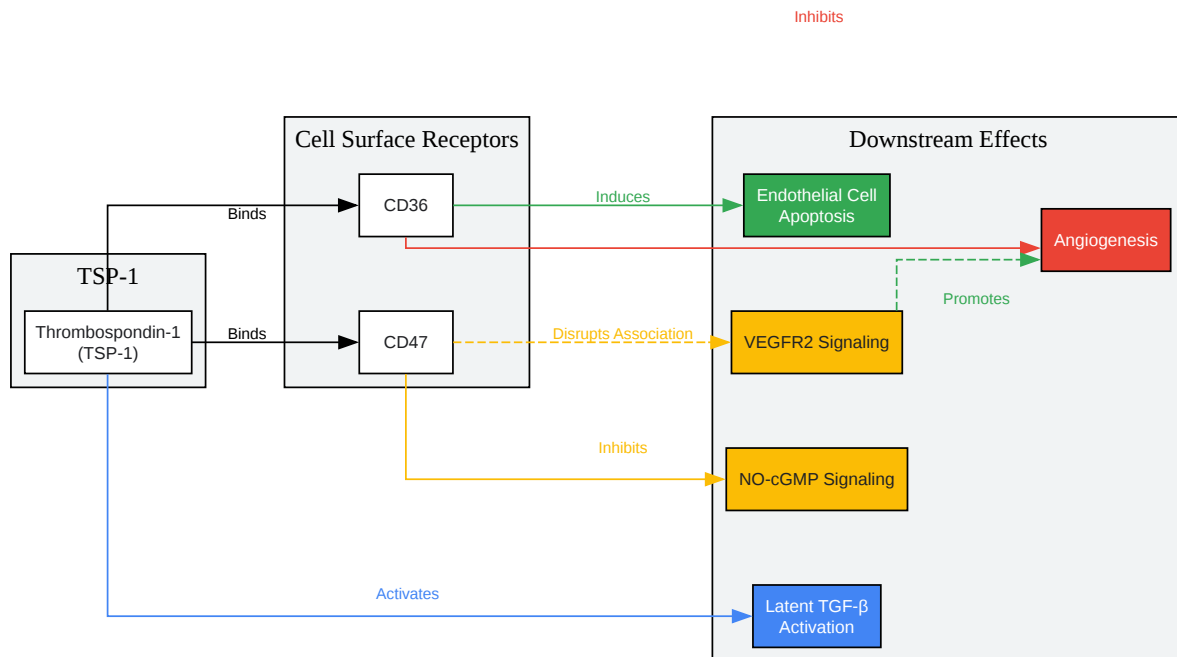

[Click to download full resolution via product page](#)

Caption: Key signaling pathways modulated by TSP-1 through its receptors CD36 and CD47.

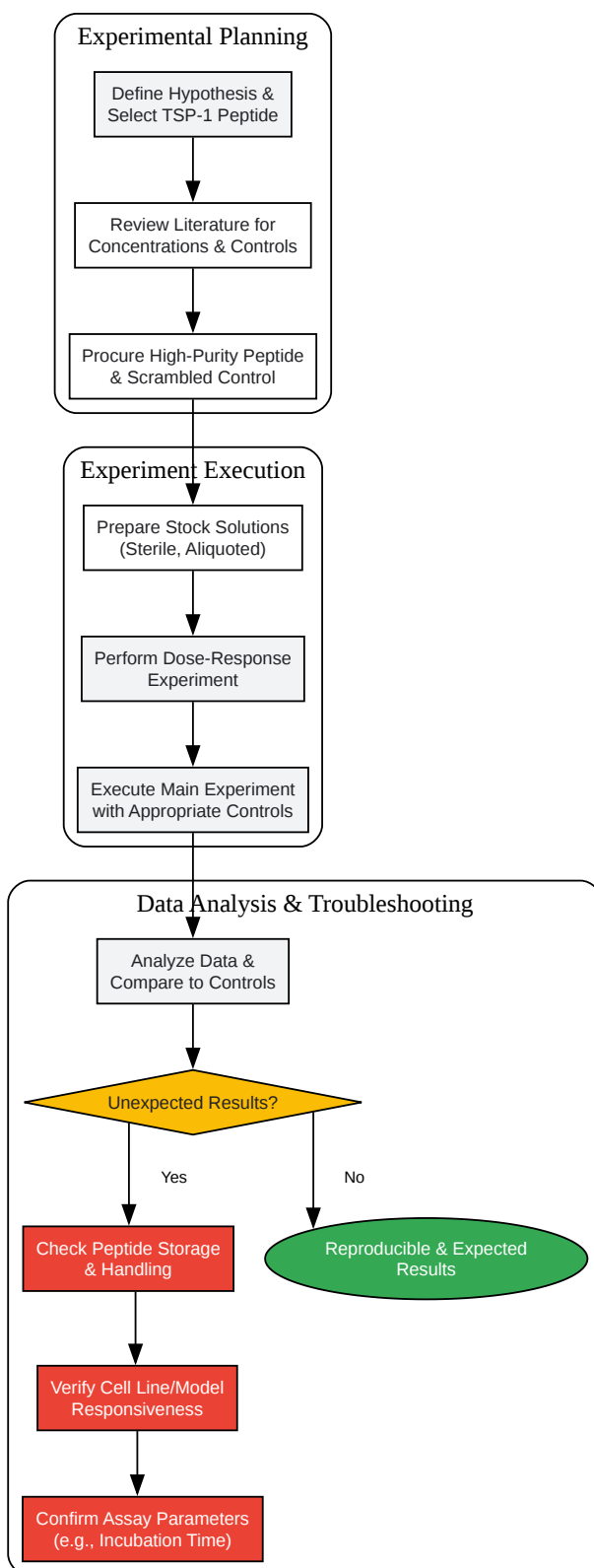

[Click to download full resolution via product page](#)

Caption: A logical workflow for TSP-1 peptide experiments, including key troubleshooting checkpoints.

Need Custom Synthesis?

BenchChem offers custom synthesis for rare earth carbides and specific isotopic labeling.

Email: info@benchchem.com or [Request Quote Online](#).

References

- [1. medchemexpress.com \[medchemexpress.com\]](https://www.medchemexpress.com)
- [2. SLLK, Control Peptide for TSP1 Inhibitor acetate | TargetMol \[targetmol.com\]](#)
- [3. academic.oup.com \[academic.oup.com\]](https://academic.oup.com)
- [4. Active peptides of TSP-1 inhibit retinal angiogenesis through the CD36 pathway in a rat model of choroidal neovascularization | PLOS One \[journals.plos.org\]](#)
- [5. ahajournals.org \[ahajournals.org\]](https://ahajournals.org)
- [6. Thrombospondin \(TSP-1\) Inhibitor scrambled peptide, SLLK - 1 mg \[anaspec.com\]](#)
- [7. glpbio.com \[glpbio.com\]](https://glpbio.com)
- [8. Treatment of Experimental Brain Tumors with Trombospondin-1 Derived Peptides: an In Vivo Imaging Study - PMC \[pmc.ncbi.nlm.nih.gov\]](#)
- [9. Thrombospondin-1 Inhibits VEGF Receptor-2 Signaling by Disrupting Its Association with CD47 - PMC \[pmc.ncbi.nlm.nih.gov\]](#)
- [10. biopharminternational.com \[biopharminternational.com\]](https://biopharminternational.com)
- To cite this document: BenchChem. [Ensuring Reproducibility of TSP-1 Peptide Experiments: A Technical Support Guide]. BenchChem, [2026]. [Online PDF]. Available at: [\[https://www.benchchem.com/product/b12374626/docs#ensuring-reproducibility-of-tsp-1-peptide-experiments-a-technical-support-guide\]](https://www.benchchem.com/product/b12374626/docs#ensuring-reproducibility-of-tsp-1-peptide-experiments-a-technical-support-guide)

Disclaimer & Data Validity:

The information provided in this document is for Research Use Only (RUO) and is strictly not intended for diagnostic or therapeutic procedures. While BenchChem strives to provide

accurate protocols, we make no warranties, express or implied, regarding the fitness of this product for every specific experimental setup.

Technical Support: The protocols provided are for reference purposes. Unsure if this reagent suits your experiment?

Need Industrial/Bulk Grade? [Request Custom Synthesis Quote](#)

BenchChem

Our mission is to be the trusted global source of essential and advanced chemicals, empowering scientists and researchers to drive progress in science and industry.

Contact

Address: 3281 E Guasti Rd

Ontario, CA 91761, United States

Phone: (601) 213-4426

Email: info@benchchem.com

[Contact our Ph.D. Support Team for a compatibility check](#)