

A Comparative Guide to the Quantification of Repaglinide: Linearity, Accuracy, and Precision

Author: BenchChem Technical Support Team. **Date:** April 2026

Compound of Interest

Compound Name: Repaglinide M2-D5

Cat. No.: B12374705

[Get Quote](#)

For researchers, scientists, and drug development professionals, the precise and reliable quantification of active pharmaceutical ingredients is paramount. This guide provides an objective comparison of various analytical methods for the quantification of Repaglinide, a prominent oral antidiabetic drug. The following sections detail the performance characteristics of High-Performance Liquid Chromatography with UV detection (HPLC-UV), High-Performance Thin-Layer Chromatography (HPTLC), and Liquid Chromatography with tandem mass spectrometry (LC-MS/MS), supported by experimental data to aid in method selection and development.

Performance Comparison of Analytical Methods

The selection of an analytical method for Repaglinide quantification is often a trade-off between sensitivity, selectivity, cost, and the nature of the sample matrix. The following tables summarize the key performance parameters of linearity, accuracy, and precision for HPLC-UV, HPTLC, and LC-MS/MS methods as reported in various validation studies.

Table 1: HPLC-UV Methods

Linearity Range	Correlation Coefficient (r ²)	Accuracy (% Recovery)	Precision (%RSD)	Matrix
100–500 µg/ml[1]	Not Specified	Not Specified	< 2%[1]	Pharmaceutical Dosage Form
1–6 µg/mL[2]	0.9996[2]	99.72% to 100.33%[2]	Not Specified	Bulk and Tablet
0.1 to 0.5 µg/ml[3]	Not Specified	Not Specified	Intra-day: 0.48 to 1.01, Inter-day: 0.15 to 1.15[3]	Pharmaceutical Dosage Form
5-50 µg/ml[4]	> 0.999[4]	99.71-100.25% [4]	< 1.50%[4]	Pharmaceutical Dosage Form
0.1-1.2 µg/ml[5]	0.9986[5]	Not Specified	Not Specified	In vitro permeation studies
2-10 µg/ml[6]	0.9960[6]	99.34%[6]	Intra-day: 0.5894-0.7344, Inter-day: 0.4378-0.8105[6]	Tablet Formulation
55-550 ng/mL[7]	0.9995[7]	95%[7]	Intra-day: 0.26-0.78, Inter-day: 1.30-1.56[7]	Rabbit Plasma
10 - 1000 ng/mL	≥ 98.17%	≤ 2.9% (intra- and inter- day)	Rabbit Plasma	

Table 2: HPTLC Methods

Linearity Range	Correlation Coefficient (r^2)	Accuracy (% Recovery)	Precision (%RSD)	Matrix
500-2500 ng/band[8]	0.9988[8]	Not Specified	< 2% (repeatability), Inter-day: 0.518 ± 0.196[8]	Bulk Drug
50-800 ng/spot	0.998	Validated	Validated	Bulk and Nanoemulsion
300 to 3000 ng/mL	0.9991	97.98 to 98.89 %	Validated	Tablet Dosage Form
400–2400 ng/spot	Validated	97.0 to 99.0%	Intra-day: 0.7 to 2.6, Inter-day: 0.8 to 3.2	Tablet Formulations

Table 3: LC-MS/MS Methods

Linearity Range	Correlation Coefficient (r^2)	Accuracy (%)	Precision (%RSD)	Matrix
0.5 - 100 ng/ml	Validated	89.31% and 101.77% (Intra-day)	3.25% - 4.36% (Intra-day)	Human Plasma
0.050–50 ng/mL	Validated	≤5.07%	≤11.2%	Human Plasma

Experimental Protocols

Detailed methodologies are crucial for the replication and validation of analytical methods. Below are representative protocols for the quantification of Repaglinide using HPLC-UV and LC-MS/MS.

HPLC-UV Method for Pharmaceutical Dosage Forms

- Chromatographic Conditions:
 - Column: C18 column (e.g., 250 x 4.6 mm, 5 μm particle size).

- Mobile Phase: A mixture of an organic solvent (e.g., Acetonitrile or Methanol) and an aqueous buffer (e.g., Ammonium Acetate or Potassium Dihydrogen Phosphate), with the pH adjusted as needed (e.g., pH 3.0)[1]. The ratio is typically isocratic (e.g., 70:30, v/v).
- Flow Rate: 1.0 mL/min.
- Detection: UV detection at a wavelength between 230 nm and 245 nm[2].
- Standard Solution Preparation:
 - A stock solution of Repaglinide is prepared in a suitable solvent like methanol (e.g., 500 µg/mL).
 - Working standard solutions are prepared by diluting the stock solution to achieve concentrations within the desired linear range.
- Sample Preparation (Tablets):
 - A number of tablets are weighed and finely powdered.
 - An amount of powder equivalent to a specific dose of Repaglinide is accurately weighed and transferred to a volumetric flask.
 - The drug is extracted with a suitable solvent (e.g., methanol), sonicated to ensure complete dissolution, and diluted to the final volume.
 - The solution is then filtered before injection into the HPLC system.
- Validation Parameters:
 - Linearity: Assessed by analyzing a minimum of five concentrations across the specified range.
 - Accuracy & Precision: Determined by the analysis of replicate quality control (QC) samples at low, medium, and high concentrations.
 - Selectivity: Evaluated by analyzing blank matrix samples to ensure no interference with the Repaglinide peak.

LC-MS/MS Method for Biological Matrices (Human Plasma)

This method offers high sensitivity and is ideal for pharmacokinetic studies.

- Chromatographic and Mass Spectrometric Conditions:
 - Mass Spectrometer: A triple quadrupole mass spectrometer operating in multiple reaction monitoring (MRM) mode.
 - Ionization: Electrospray ionization (ESI) is commonly used.
- Sample Preparation (Plasma):
 - Protein Precipitation: A straightforward method where a precipitating agent like acetonitrile is added to the plasma sample. The mixture is then centrifuged to remove the precipitated proteins.
 - Liquid-Liquid Extraction: An alternative method where the analyte is extracted from the plasma using an immiscible organic solvent (e.g., tert-butyl methyl ether).
- Validation Parameters (in accordance with FDA/EMA guidelines):
 - Selectivity: Assessed using at least six different sources of blank matrix.
 - Lower Limit of Quantification (LLOQ): The lowest concentration on the calibration curve that can be quantified with acceptable precision and accuracy.
 - Matrix Effect: Evaluated to ensure that components in the biological matrix do not suppress or enhance the ionization of the analyte.
 - Stability: Assessed under various conditions including freeze-thaw cycles, short-term storage, and long-term storage.

Visualizations

Repaglinide's Mechanism of Action

Repaglinide stimulates insulin secretion from pancreatic β -cells by binding to and inhibiting the ATP-sensitive potassium (KATP) channels on the cell membrane. This action leads to a cascade of events culminating in the release of insulin.

Repaglinide Signaling Pathway for Insulin Secretion

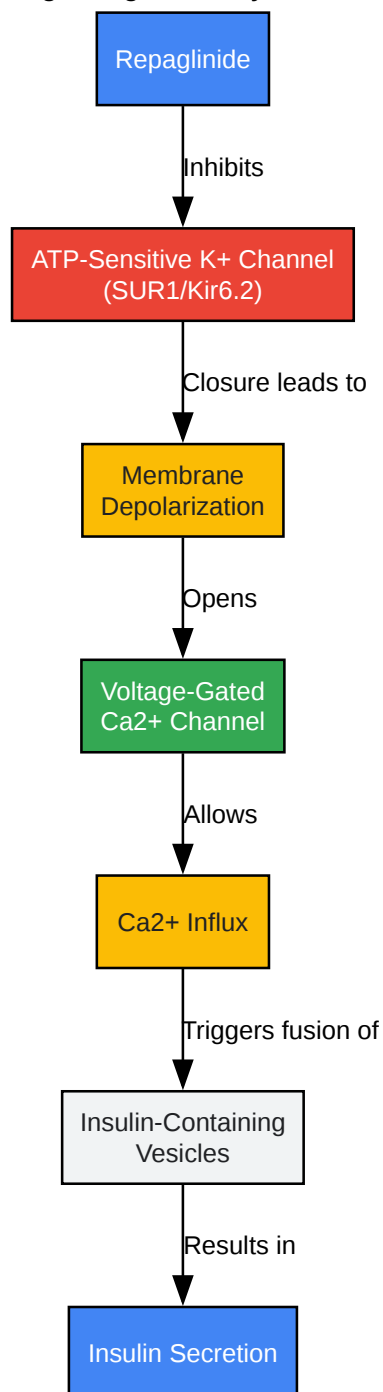

[Click to download full resolution via product page](#)

Caption: Mechanism of Repaglinide-induced insulin secretion.

Experimental Workflow for Repaglinide Quantification

The following diagram illustrates a typical experimental workflow for the quantification of Repaglinide in a given sample matrix using a chromatographic technique.

General Workflow for Repaglinide Quantification

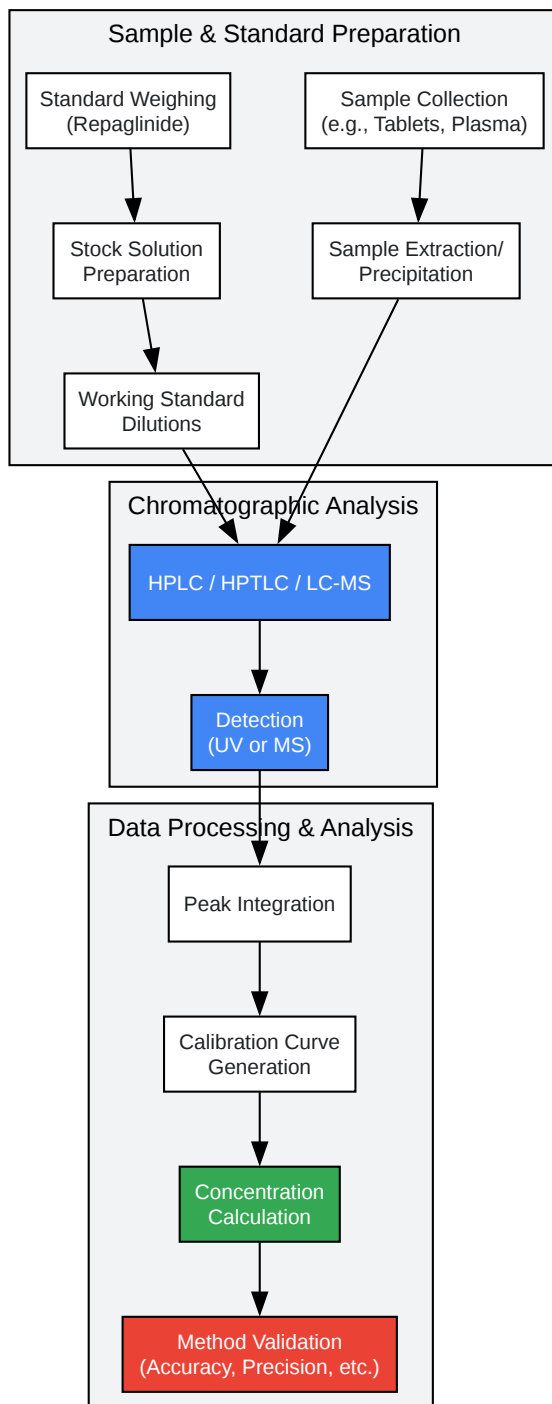

[Click to download full resolution via product page](#)

Caption: A typical workflow for Repaglinide analysis.

Need Custom Synthesis?

BenchChem offers custom synthesis for rare earth carbides and specific isotopic labeling.

Email: info@benchchem.com or [Request Quote Online](#).

References

- [1. go.drugbank.com](https://go.drugbank.com) [go.drugbank.com]
- [2. Repaglinide - Wikipedia](https://en.wikipedia.org) [en.wikipedia.org]
- [3. ClinPGx](https://clinpgx.org) [clinpgx.org]
- [4. The Structural Basis for the Binding of Repaglinide to the Pancreatic KATP Channel - PubMed](#) [pubmed.ncbi.nlm.nih.gov]
- [5. ClinPGx](https://clinpgx.org) [clinpgx.org]
- [6. rcsb.org](https://rcsb.org) [rcsb.org]
- [7. Sulfonylurea action re-revisited - PMC](#) [pmc.ncbi.nlm.nih.gov]
- [8. Kir6.2-dependent high-affinity repaglinide binding to beta-cell K\(ATP\) channels - PubMed](#) [pubmed.ncbi.nlm.nih.gov]
- To cite this document: BenchChem. [A Comparative Guide to the Quantification of Repaglinide: Linearity, Accuracy, and Precision]. BenchChem, [2026]. [Online PDF]. Available at: [<https://www.benchchem.com/product/b12374705/docs#a-comparative-guide-to-the-quantification-of-repaglinide-linearity-accuracy-and-precision>]

Disclaimer & Data Validity:

The information provided in this document is for Research Use Only (RUO) and is strictly not intended for diagnostic or therapeutic procedures. While BenchChem strives to provide accurate protocols, we make no warranties, express or implied, regarding the fitness of this product for every specific experimental setup.

Technical Support: The protocols provided are for reference purposes. Unsure if this reagent suits your experiment?

Need Industrial/Bulk Grade? [Request Custom Synthesis Quote](#)

BenchChem

Our mission is to be the trusted global source of essential and advanced chemicals, empowering scientists and researchers to drive progress in science and industry.

Contact

Address: 3281 E Guasti Rd

Ontario, CA 91761, United States

Phone: (601) 213-4426

Email: info@benchchem.com

[Contact our Ph.D. Support Team for a compatibility check](#)