

# Validating Kp7-6 Activity: A Comparative Guide for New Cell Line Integration

**Author:** BenchChem Technical Support Team. **Date:** December 2025

## Compound of Interest

Compound Name: Kp7-6

Cat. No.: B12373095

[Get Quote](#)

For Researchers, Scientists, and Drug Development Professionals

This guide provides a comprehensive framework for validating the activity of **Kp7-6**, a Fas mimetic peptide and Fas/FasL antagonist, in a new cell line. It offers a direct comparison with an alternative Fas/FasL inhibitor, Asunercept (APG101), and includes detailed experimental protocols and data interpretation guidelines to ensure robust and reliable results.

## Introduction to Kp7-6 and Fas/FasL Signaling

**Kp7-6** is a peptide-based antagonist of the Fas/FasL signaling pathway, designed to protect cells from Fas-mediated apoptosis.<sup>[1][2][3]</sup> The Fas receptor (also known as CD95 or APO-1) and its ligand (FasL) are key regulators of programmed cell death. Their interaction triggers a signaling cascade that culminates in apoptosis, a critical process in immune homeostasis and tissue development. Dysregulation of this pathway is implicated in various diseases, making it a prime target for therapeutic intervention.

**Kp7-6** functions by binding to both the Fas receptor and FasL, which leads to the formation of a defective signaling complex.<sup>[4][5]</sup> This interference modulates downstream signaling by activating the pro-survival NF- $\kappa$ B pathway and inhibiting the pro-apoptotic ERK pathway, without affecting the JNK pathway. This unique mechanism "desensitizes" the cell to apoptotic stimuli. **Kp7-6** exhibits specificity for the Fas receptor complex and does not interact with other members of the tumor necrosis factor (TNF) receptor superfamily, such as TNF- $\alpha$ .

## Comparative Compound: Asunercept (APG101)

For a comprehensive validation of **Kp7-6**'s activity, this guide uses Asunercept (also known as APG101) as a comparator. Asunercept is a soluble CD95-Fc fusion protein that acts as a FasL inhibitor by binding to and neutralizing CD95L, thereby preventing its interaction with the Fas receptor. This direct ligand sequestration mechanism provides a valuable benchmark against which to compare the more complex, modulatory activity of **Kp7-6**.

## Experimental Validation Workflow

The following workflow outlines a systematic approach to validating **Kp7-6** activity in a new cell line.

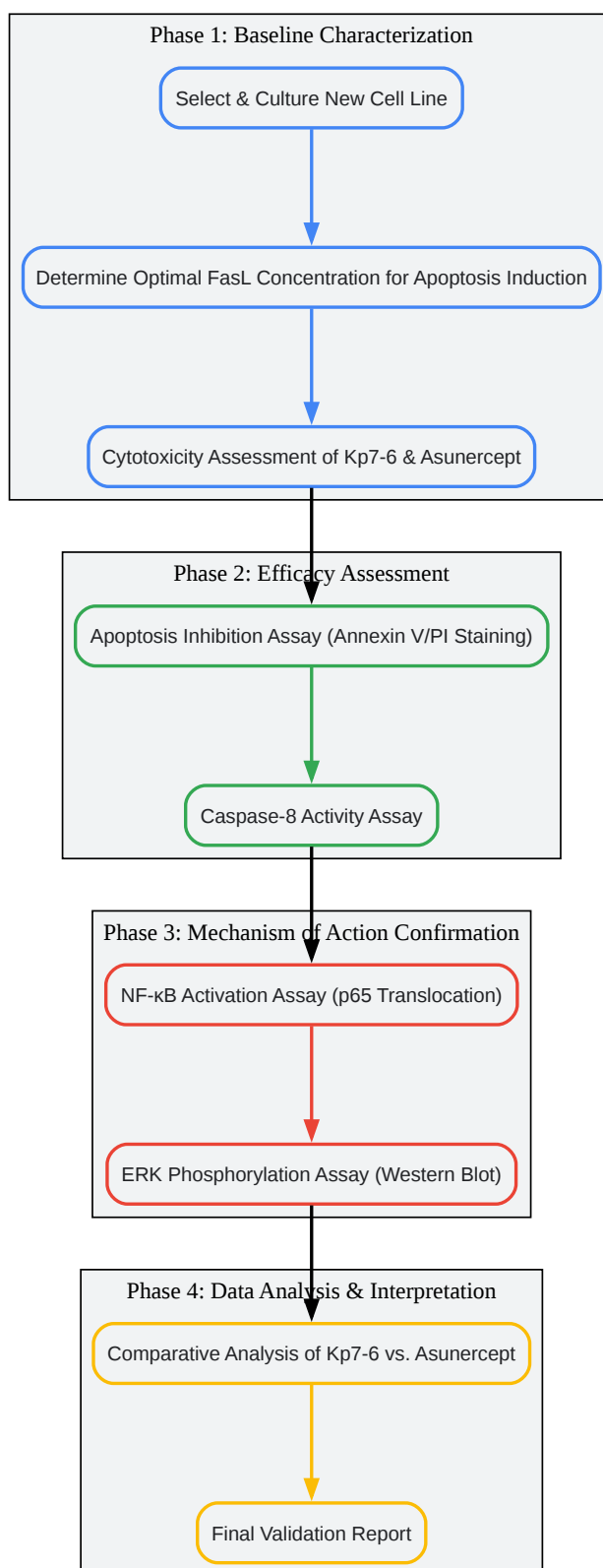

[Click to download full resolution via product page](#)

**Figure 1:** Experimental workflow for validating **Kp7-6** activity.

## Data Presentation: Comparative Analysis

The following tables summarize hypothetical data from the experimental workflow, comparing the efficacy and mechanism of action of **Kp7-6** and Asunercept.

Table 1: Cytotoxicity and Apoptosis Inhibition

Parameter	Kp7-6	Asunercept	Vehicle Control
CC50 (μM)	> 100	> 100	N/A
IC50 (Apoptosis Inhibition, μM)	15.2	25.8	N/A
Maximal Apoptosis Inhibition (%)	85.3	92.1	0
Caspase-8 Activity Inhibition (%)	78.5	88.9	0

Table 2: Mechanism of Action Analysis

Parameter	Kp7-6	Asunercept	FasL Only	Untreated Control
NF-κB p65 Nuclear Translocation (Fold Change)	3.5	1.2	1.1	1.0
p-ERK/Total ERK Ratio (Fold Change)	0.4	0.9	2.8	1.0

## Kp7-6 Signaling Pathway

The diagram below illustrates the proposed signaling pathway of **Kp7-6** in modulating Fas/FasL-induced apoptosis.

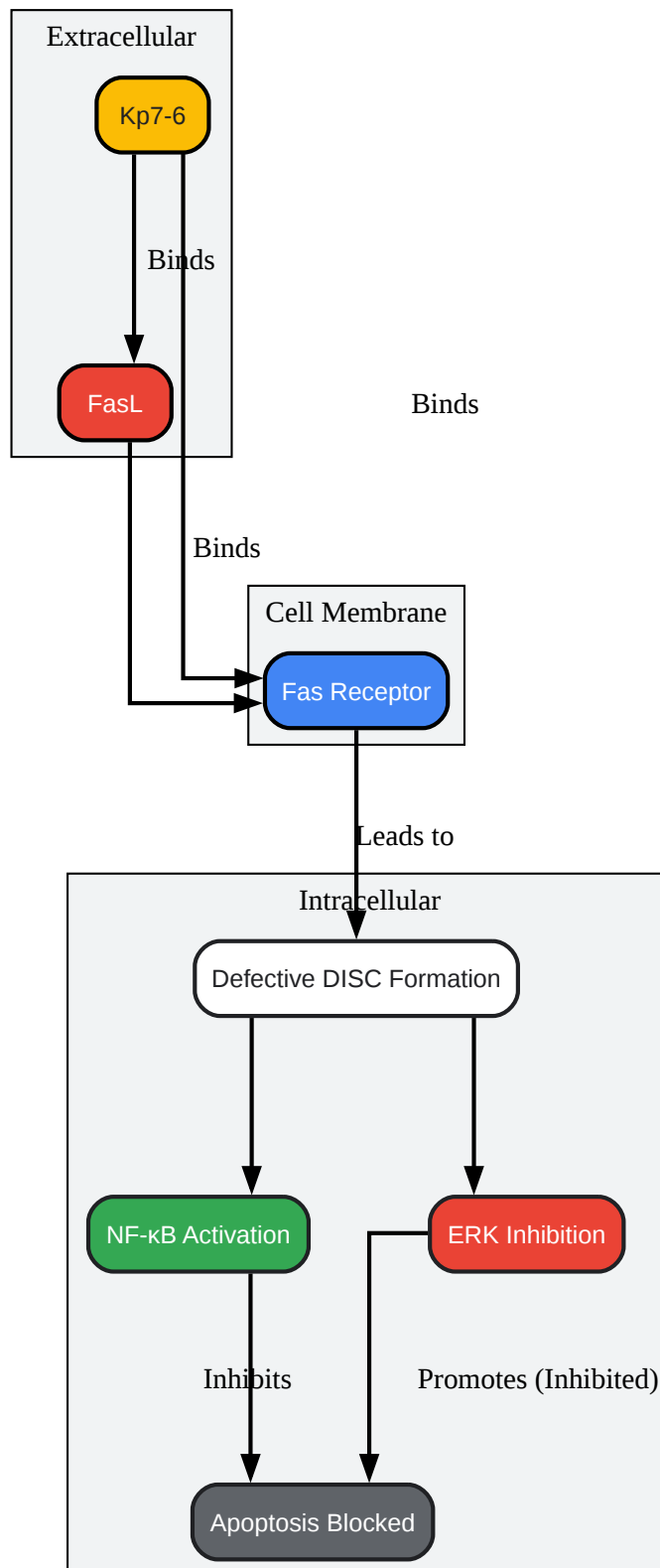

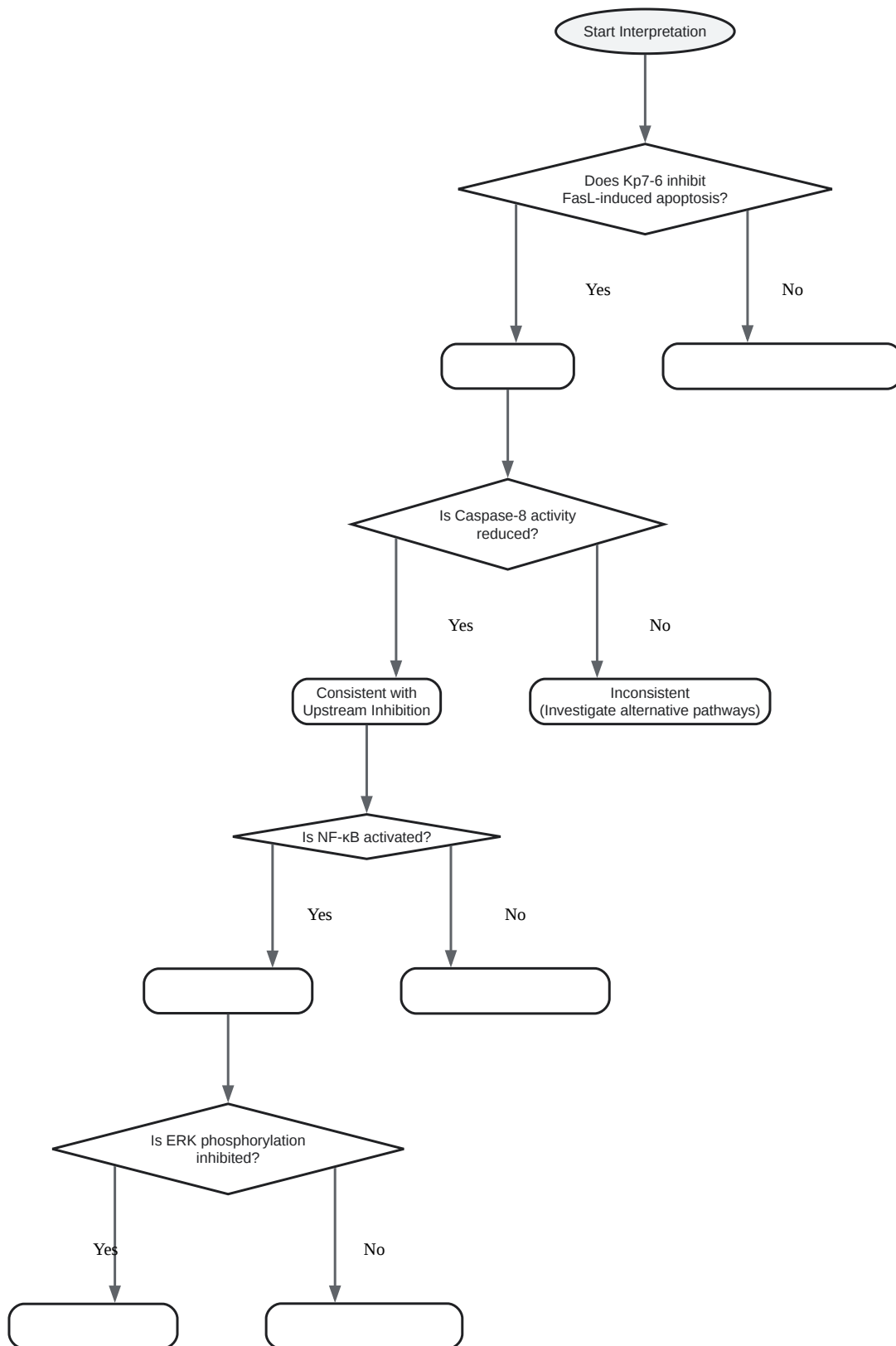

[Click to download full resolution via product page](#)

### Need Custom Synthesis?

BenchChem offers custom synthesis for rare earth carbides and specific isotopic labeling.

Email: [info@benchchem.com](mailto:info@benchchem.com) or [Request Quote Online](#).

## References

- 1. medchemexpress.com [medchemexpress.com]
- 2. Clinical Candidates | Apogenix [apogenix.com]
- 3. Facebook [cancer.gov]
- 4. Asunercept - Wikipedia [en.wikipedia.org]
- 5. ashpublications.org [ashpublications.org]
- To cite this document: BenchChem. [Validating Kp7-6 Activity: A Comparative Guide for New Cell Line Integration]. BenchChem, [2025]. [Online PDF]. Available at: [https://www.benchchem.com/product/b12373095#validating-kp7-6-activity-in-a-new-cell-line]

---

### Disclaimer & Data Validity:

The information provided in this document is for Research Use Only (RUO) and is strictly not intended for diagnostic or therapeutic procedures. While BenchChem strives to provide accurate protocols, we make no warranties, express or implied, regarding the fitness of this product for every specific experimental setup.

**Technical Support:** The protocols provided are for reference purposes. Unsure if this reagent suits your experiment? [[Contact our Ph.D. Support Team for a compatibility check](#)]

**Need Industrial/Bulk Grade?** [Request Custom Synthesis Quote](#)

# BenchChem

Our mission is to be the trusted global source of essential and advanced chemicals, empowering scientists and researchers to drive progress in science and industry.

## Contact

Address: 3281 E Guasti Rd

Ontario, CA 91761, United States

Phone: (601) 213-4426

Email: [info@benchchem.com](mailto:info@benchchem.com)