

Physical properties of sodium L-gulonate in solution

Author: BenchChem Technical Support Team. Date: April 2026

Compound of Interest

Compound Name: L-Guluronic acid (sodium salt)

Cat. No.: B12373610

[Get Quote](#)

An In-depth Technical Guide to the Physical Properties of Sodium L-Gulonate in Solution

Foreword

Sodium L-gulonate, a constituent monomer of the natural polysaccharide alginate, is a cornerstone of research in biomaterials, drug delivery, and food science. Its unique solution properties and, most notably, its capacity for ion-tropic gelation, grant it functionalities that are both versatile and highly controllable. This document provides an in-depth exploration of the physical chemistry of sodium L-gulonate in aqueous solutions. We will move beyond simple descriptions to mechanistic underpinnings of its behavior, offering not just data, but a framework for understanding and manipulating this remarkable biopolymer for various applications. This document is intended for researchers, scientists, and drug development professionals who require a deep and practical understanding of this material.

Molecular and Chemical Foundation

Sodium L-gulonate is the sodium salt of L-guluronic acid, a uronic acid and a C-5 epimer of D-mannuronic acid.[1] In nature, it rarely exists as a free monomer but is found as a key building block within alginate, a linear copolymer extracted from the cell walls of brown seaweed (Phaeophyceae).[2][3] Alginate's structure consists of blocks of (1 → 4)-linked β-D-mannuronic acid (M-blocks), blocks of α-L-guluronic acid (G-blocks), and alternating sequences (MG-blocks). The physical properties of any given alginate are critically dependent on the ratio and distribution of these blocks.[6] This guide focuses on the properties of the L-gulonate component.

Core Chemical Structure

The fundamental chemical identity of sodium L-gulonate dictates its behavior in solution.

- Molecular Formula: $C_6H_{11}O_7Na$ [7]
- Molecular Weight: Approximately 218.14 g/mol [7]
- Key Functional Groups: The molecule possesses a carboxylate group ($-COO^-Na^+$) and multiple hydroxyl groups ($-OH$). These hydrophilic groups are responsible for its water solubility and its ability to engage in hydrogen bonding.[8]

Caption: Chair conformation of Sodium α-L-gulonate.

Solution Behavior: Solubility and Viscosity

When dissolved, sodium L-gulonate chains, typically as part of an alginate polymer, dictate the macroscopic properties of the solution.

Solubility

Sodium L-gulonate, as a component of sodium alginate, is soluble in both hot and cold water, forming a viscous solution. However, its solubility is not uniform; it is highly dependent on the solution's chemical environment.

- **Influence of pH:** The solubility is critically dependent on the protonation state of the carboxyl group. At a pH below the pKa of guluronic acid (approx the carboxyl groups become protonated (-COOH)).^{[5][9]} This neutralizes the charge, reduces repulsion between polymer chains, and promotes inter hydrogen bonding, leading to the formation of insoluble alginic acid and precipitation or acid gel formation.^[9]
- **Influence of Ionic Strength:** In solutions with low ionic strength, the negatively charged carboxyl groups on the polymer chains lead to electrostatic repulsion causing the chains to adopt an extended, rigid conformation. The addition of monovalent salts (like NaCl) shields these charges, allowing the polymer to become more flexible and coiled, which can influence viscosity.^{[10][11]}
- **Solvent Limitations:** Sodium alginate is insoluble in organic solvents and in hydroalcoholic solutions with an alcohol content exceeding 30%.^[5]

Parameter	Condition	Effect on Solubility	Mechanism
pH	pH < 3.6	Decreased Solubility / Precipitation	Protonation of carboxylate groups forms insoluble alginic acid. ^{[5][9]}
pH	pH > 3.6	Soluble	Ionization of carboxyl groups (-COO ⁻) enhances hydration and chain repulsion.
Ionic Strength	Addition of Monovalent Cations (e.g., Na ⁺)	Generally soluble	Charge shielding allows for more compact chain conformations. ^[10]
Divalent Cations	Addition of Ca ²⁺ , Ba ²⁺ , Sr ²⁺	Leads to Gelation (Insolubilization)	Ion-mediated cross-linking between polymer chains. ^{[10][12]}
Solvent	>30% Ethanol	Insoluble	Disruption of the hydration shell around the polymer. ^[5]

Viscosity and Rheological Profile

Aqueous solutions of sodium alginate are not simple Newtonian fluids; their viscosity changes with applied stress.^[5]

- **Pseudoplastic (Shear-Thinning) Behavior:** Alginate solutions exhibit pseudoplastic, or shear-thinning, behavior.^[13] This means their apparent viscosity decreases as the shear rate increases. At rest, the long polymer chains are randomly entangled. When shear is applied (e.g., by stirring or pumping), the chains align in the direction of flow, reducing resistance and thus lowering the measured viscosity.^{[13][14]}
- **Factors Influencing Viscosity:**
 - **Concentration:** As the concentration of sodium alginate increases, the polymer chains become more entangled, leading to a logarithmic increase in viscosity.
 - **Molecular Weight:** Higher molecular weight polymers have longer chains, resulting in more significant entanglement and an exponential increase in viscosity.^{[15][16]}
 - **Temperature:** Increasing the temperature generally decreases the viscosity of the solution.^[5]
 - **pH:** Viscosity tends to increase as the pH is lowered towards the pKa, reaching a maximum around pH 3-3.5 due to increased hydrogen bonding and precipitation.^[5]

The "Egg-Box" Model: Mechanism of Ion-tropic Gelation

The most defining characteristic of polymers rich in L-guluronate is their ability to form hydrogels in the presence of divalent cations. This process is described by the "egg-box" model.^{[4][16]}

The Role of Divalent Cations

While monovalent cations like Na⁺ simply associate with the carboxylate groups, certain divalent cations, particularly Ca²⁺, Ba²⁺, and Sr²⁺, act as cross-linking agents.^{[10][12]} These ions have the correct size and charge density to bind cooperatively between different polymer chains.

The G-Block Conformation

The chair conformation of the α -L-guluronate residues creates a cavity-like structure along the polymer chain.[17][18] These "cavities" are lined with c from the carboxyl and hydroxyl groups, creating an ideal coordination site for divalent cations. M-blocks, due to their different stereochemistry, do not specific structure and are less effective at binding divalent cations.[9]

Formation of the Junction Zone

The gelation process occurs when a divalent cation, such as Ca^{2+} , displaces the sodium ions and becomes coordinated between two G-blocks on ad chains.[15][16] This creates a stable, three-dimensional network. The structure formed by the G-blocks encapsulating the calcium ions is likened to eg egg carton, hence the name "egg-box model." [4] Alginates with a higher G-block content form stronger, more rigid, but also more brittle gels.[6][19][20]

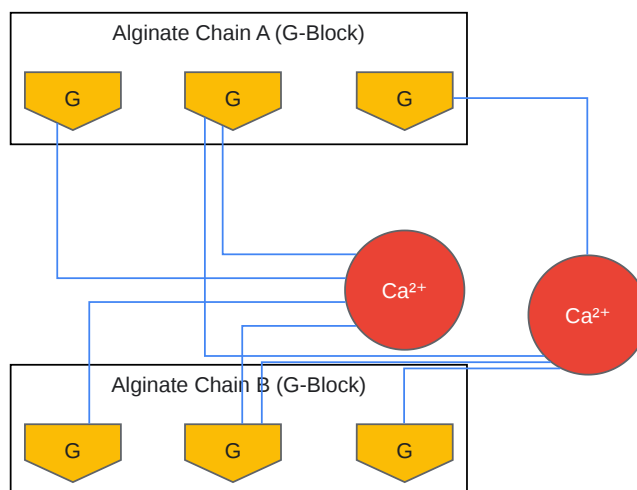

[Click to download full resolution via product page](#)

Caption: The "Egg-Box" model for calcium-alginate gelation.

Experimental Characterization Protocols

To harness the properties of sodium L-guluronate, rigorous characterization is essential. The following protocols outline standard methodologies.

Protocol: Rheological Analysis of Sodium Alginate Solutions

This protocol describes the determination of the flow behavior (viscosity vs. shear rate) of a sodium alginate solution using a rotational rheometer.

Objective: To quantify the pseudoplastic (shear-thinning) nature of the solution.

Materials & Equipment:

- Rotational rheometer with parallel plate or cone-and-plate geometry[13][21]
- Sodium alginate powder
- Deionized water
- Analytical balance
- Magnetic stirrer and stir bar
- Spatula and weighing paper

Procedure:

- Solution Preparation: a. Accurately weigh the required amount of sodium alginate powder to prepare a solution of desired concentration (e.g., 1% w/v) add the powder to the vortex of stirred deionized water to prevent clumping. c. Continue stirring at a low-to-moderate speed for several hours (or at room temperature until a clear, homogenous solution is formed.[21]
- Rheometer Setup: a. Set the rheometer temperature to the desired value (e.g., 25°C).[13] b. Zero the gap between the geometry plates. c. Set the gap according to the manufacturer's recommendation (e.g., 500-1000 μm).
- Sample Loading: a. Carefully pipette the prepared solution onto the center of the lower plate, ensuring enough sample to slightly overfill the gap. b. upper geometry to the set gap, trimming any excess sample from the edge. c. Allow the sample to equilibrate at the set temperature for at least 5 min
- Measurement: a. Perform a steady-state shear sweep test.[21] b. Define a range of shear rates, for example, from 0.1 to 1000 s^{-1} .[13] c. Record the viscosity at each shear rate.
- Data Analysis: a. Plot the apparent viscosity (Pa-s) as a function of the shear rate (s^{-1}) on a log-log scale. b. The resulting curve will demonstrate thinning behavior, with viscosity decreasing at higher shear rates.

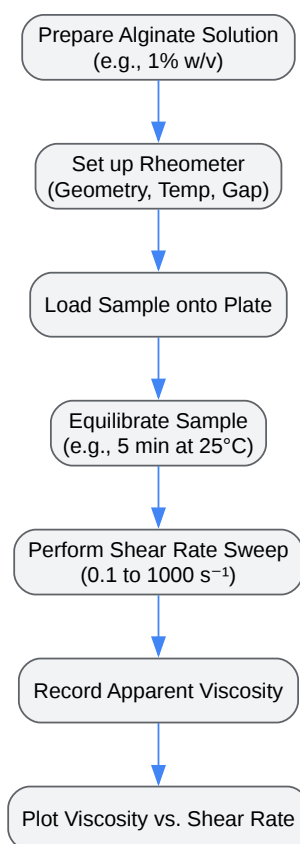

[Click to download full resolution via product page](#)

Caption: Workflow for Rheological Characterization.

Protocol: Intrinsic Viscosity Measurement for Molecular Weight Estimation

This protocol uses a capillary viscometer to determine the intrinsic viscosity, which can be related to the average molecular weight via the Mark-Houwink [11]

Objective: To determine the intrinsic viscosity $[\eta]$ of a sodium alginate sample.

Materials & Equipment:

- Ubbelohde capillary viscometer^[11]
- Constant temperature water bath (e.g., 25°C ± 0.1°C)
- Stopwatch
- Volumetric flasks and pipettes
- Sodium alginate
- Solvent (e.g., 0.1 M NaCl solution to suppress polyelectrolyte effects)^[11]

Procedure:

- Stock Solution Preparation: Prepare a stock solution of sodium alginate in 0.1 M NaCl at a known concentration (e.g., 0.1 g/dL).
- Serial Dilutions: Prepare a series of dilutions from the stock solution (e.g., 0.08, 0.06, 0.04, 0.02 g/dL).
- Viscometer Measurement: a. Equilibrate the viscometer and all solutions in the constant temperature water bath. b. Measure the flow time (t_0) of the solvent (0.1 M NaCl). c. For each polymer dilution, measure the flow time (t) through the capillary. Perform at least three measurements per concentration and average the results.
- Calculations: a. Relative Viscosity (η_{rel}): $\eta_{rel} = t / t_0$ b. Specific Viscosity (η_{sp}): $\eta_{sp} = \eta_{rel} - 1$ c. Reduced Viscosity (η_{red}): $\eta_{red} = \eta_{sp} / c$ (concentration) d. Inherent Viscosity (η_{inh}): $\eta_{inh} = \ln(\eta_{rel}) / c$
- Data Analysis (Huggins & Kraemer Plots): a. Huggins Plot: Plot η_{red} versus concentration. The y-intercept is the intrinsic viscosity $[\eta]$. The slope is k_H where k_H is the Huggins coefficient.^[22] b. Kraemer Plot: Plot η_{inh} versus concentration. The y-intercept is also the intrinsic viscosity $[\eta]$. c. Extra linear fits of both plots to zero concentration. The intercept on the y-axis gives the intrinsic viscosity $[\eta]$.^[11]

Conclusion

The physical properties of sodium L-gulonate in solution are a direct consequence of its molecular structure. Its solubility, viscosity, and unique ability to form specific hydrogels are governed by the interplay of its carboxylate and hydroxyl groups with the surrounding solvent and ionic species. An understanding of shear-thinning rheology and the "egg-box" gelation mechanism is fundamental for any scientist or engineer looking to exploit this biopolymer. The procedures herein serve as a starting point for the precise characterization required to develop robust and reliable applications, from controlled-release drug form to advanced tissue engineering scaffolds.

References

- SODIUM GULONATE, L- - gsrs. [URL: https://vertexaisearch.cloud.google.com/grounding-api-redirect/AUZIYQGMZP4Ld_YzPfxIvujBNyVwpAwHLldEbB_OjpaYu-5eMHpfMOD7RI6XxKWeygMon8TkQANG-VRoeJLdTxbHtBHwkahMA_EoXyX3aGHjKmRSQniEyKll6joX7NDNTGcdkoZfbO3oKx8tvHsdPjz0q2Bd4eGw==]
- Characterization of poly-D-mannuronate and poly-L-gulonate block fractions from sodium alginate and preparation of hydrogels with poly(vinylalcohol) [URL: <https://pubmed.ncbi.nlm.nih.gov/29355633/>]
- Guluronic acid sodium | C6H9NaO7 | CID 87514952 - PubChem - NIH. [URL: <https://pubchem.ncbi.nlm.nih.gov/compound/Guluronic-acid-sodium>]
- Chemical structure of: (a) α -L-gulonate (G) and β -D-mannuronate (M) residues present in sodium alginate... - ResearchGate. [URL: <https://www.researchgate.net/publication/32510762>]
- What is the mechanism of Sodium Alginate? - Patsnap Synapse. [URL: <https://www.patsnap.com/question/what-is-the-mechanism-of-sodium-alginate>]
- L-Guluronic Acid Sodium Salt | CAS:15769-56-9 | High Purity - BioCrick. [URL: <https://www.biocrick.com/L-Guluronic-Acid-Sodium-Salt-BCN9815.html>]
- Sodium Alginate Toughening of Gelatin Hydrogels and Elucidation of Possible Mechanisms - Rose-Hulman Scholar. [URL: https://scholar.rose-hulman.edu/cgi/viewcontent.cgi?article=1374&context=rhit_journal]
- CAS 32510-76-2 (L-Guluronic acid sodium salt) - BOC Sciences. [URL: <https://www.bocsci.com/product/l-guluronic-acid-sodium-salt-cas-32510-76-2>]
- Deciphering the Effect of Microstructural Modification in Sodium Alginate-Based Solid Polymer Electrolyte by Unlike Anions | ACS Omega. [URL: <https://pubs.acs.org/doi/10.1021/acsomega.3c05987>]
- L-gulonate | C6H9O7- | CID 6857564 - PubChem. [URL: <https://pubchem.ncbi.nlm.nih.gov/compound/L-gulonate>]
- Green Hydrogels Composed of Sodium Mannuronate/Gulonate, Gelatin and Biointeractive Calcium Silicates/Dicalcium Phosphate Dihydrate Described for Bone Defects Regeneration - ResearchGate. [URL: <https://www.researchgate.net/publication/32510762>]
- Physico-Chemical Properties of Sodium Alginate - Encyclopedia.pub. [URL: <https://encyclopedia.pub/entry/28615>]

- Green Hydrogels Composed of Sodium Mannuronate/Guluronate, Gelatin and Biointeractive Calcium Silicates/Dicalcium Phosphate Dihydrate Des Bone Defects Regeneration - MDPI. [URL: <https://www.mdpi.com/2073-4360/14/1/1>]
- Relevance of Rheological Properties of Sodium Alginate in Solution to Calcium Alginate Gel Properties - SciSpace. [URL: <https://typeset>]
- Effects of Molecular Weight and Guluronic Acid/Mannuronic Acid Ratio on the Rheological Behavior and Stabilizing Property of Sodium Alginate - M <https://www.mdpi.com/2073-4360/11/12/1977>]
- effect of the sodium alginate concentration and the ionic strength on the rheological properties of sodium - POLITesi. [URL: <https://www.politesi.polimi.it/handle/10589/148408>]
- Effects of M/G Ratios of Sodium Alginate on Physicochemical Stability and Calcium Release Behavior of Pickering Emulsion Stabilized by Calcium PMC. [URL: <https://www.ncbi.nlm.nih.gov/pmc/articles/PMC8796917/>]
- SODIUM ALGINATE - Ataman Kimya. [URL: <https://www.ataman-kimya>]
- RHEOLOGICAL PROPERTIES OF SODIUM ALGINATE SOLUTIONS. [URL: <https://www.revistadechimie.ro/pdf/13%20BELALIA%20F%2012%20>]
- Ions-Induced Alginate Gelation According to Elemental Analysis and a Combinatorial Approach - PMC. [URL: <https://www.ncbi.nlm.nih.gov/pmc/articles/PMC10671607/>]
- Review of the characterization of sodium alginate by intrinsic viscosity measurements. Comparative analysis between conventional - CONICET. [U https://www.conicet.gov.ar/new_scp/detalle.php?]
- (a) Molecular structure of sodium alginate, their components:... - ResearchGate. [URL: <https://www.researchgate>]
- Current Status of Alginate in Drug Delivery - PMC. [URL: <https://www.ncbi.nlm.nih.gov/pmc/articles/PMC7464522/>]
- Characterization of Sodium-Alginate-Based Hydrogels - Encyclopedia.pub. [URL: <https://encyclopedia.pub/entry/42116>]
- L-Guluronic acid sodium salt | Uronic Acid - MedchemExpress.com. [URL: <https://www.medchemexpress.com/l-guluronic-acid-sodium-salt.html>]
- Alginate-metal cation interactions: Macromolecular approach - ArTS. [URL: <https://arts.units.it/handle/11368/2928816>]
- Physical Properties - KIMICA Corporation. [URL: <https://www.kimica>]
- Characterization of Sodium Alginate Hydrogels Reinforced with Nanoparticles of Hydroxyapatite for Biomedical Applications - PMC. [URL: <https://www.ncbi.nlm.nih.gov/pmc/articles/PMC8434316/>]
- Sodium Alginate Modifications: A Critical Review of Current Strategies and Emerging Applications - PMC. [URL: <https://www.ncbi.nlm.nih.gov/pmc/articles/PMC10744655/>]
- Structures, Properties and Applications of Alginates - MDPI. [URL: <https://www.mdpi.com/2073-4360/14/11/2247>]
- Sodium alginate in drug delivery and biomedical areas - Semantic Scholar. [URL: <https://www.semanticscholar.org/paper/Sodium-alginate-in-drug-t biomedical-Jadach-%C5%9Awietlik/f20421370b3e5513f41240398013233b82736162>]
- Characterization at 25 °C of Sodium Hyaluronate in Aqueous Solutions Obtained by Transport Techniques - MDPI. [URL: <https://www.mdpi.com/143049/20/4/6076>]
- Interaction Pathways and Structure–Chemical Transformations of Alginate Gels in Physiological Environments | Biomacromolecules - ACS Publicat <https://pubs.acs.org/doi/10.1021/acs.biomac.9b01004>]
- Recent achievements in sodium alginate-based nanoparticles for targeted drug delivery. [URL: <https://www.semanticscholar.org/paper/Recent-achi sodium-alginate-based-for-Nezhad-Dargahi-Siahmard/e0c42289c0953a7e025f462a6327b87201b1735a>]
- Alginate-metal ion interactions: Influence of cationic surfactants | Request PDF. [URL: <https://www.researchgate>]
- (PDF) The Effect Of Sodium Alginate Concentration On The Rheological Parameters Of Spinning Solutions - ResearchGate. [URL: https://www.researchgate.net/publication/288647565_The_Effect_Of_Sodium_Alginate_Concentration_On_The_Rheological_Parameters_Of_Spir]
- Effect of sodium gluconate on the solubility of calcium lactate - PubMed. [URL: <https://pubmed.ncbi.nlm.nih.gov/21840523/>]
- (PDF) Sodium alginate: The wonder polymer for controlled drug delivery - ResearchGate. [URL: https://www.researchgate.net/publication/286950785_Sodium_alginate_The_wonder_polymer_for_controlled_drug_delivery]
- effect of the sodium alginate concentration and the ionic strength on the rheological properties of sodium alginate based hydrogels - POLITesi. [UR <https://www.politesi.polimi.it/handle/10589/177114>]

Need Custom Synthesis?

BenchChem offers custom synthesis for rare earth carbides and specific isotopic labeling.

Email: info@benchchem.com or [Request Quote Online](#).

Sources

1. ri.conicet.gov.ar [ri.conicet.gov.ar]
2. bocsci.com [bocsci.com]
3. [Current Status of Alginate in Drug Delivery - PMC](#) [pmc.ncbi.nlm.nih.gov]
4. [What is the mechanism of Sodium Alginate?](#) [synapse.patsnap.com]

- [5. encyclopedia.pub \[encyclopedia.pub\]](#)
- [6. Sodium Alginate Modifications: A Critical Review of Current Strategies and Emerging Applications - PMC \[pmc.ncbi.nlm.nih.gov\]](#)
- [7. GSRS \[gsrs.ncats.nih.gov\]](#)
- [8. pubs.acs.org \[pubs.acs.org\]](#)
- [9. scholar.rose-hulman.edu \[scholar.rose-hulman.edu\]](#)
- [10. politesi.polimi.it \[politesi.polimi.it\]](#)
- [11. revroum.lew.ro \[revroum.lew.ro\]](#)
- [12. researchgate.net \[researchgate.net\]](#)
- [13. mdpi.com \[mdpi.com\]](#)
- [14. researchgate.net \[researchgate.net\]](#)
- [15. Physical Properties | KIMICA Corporation \[kimica-algin.com\]](#)
- [16. scispace.com \[scispace.com\]](#)
- [17. researchgate.net \[researchgate.net\]](#)
- [18. arts.units.it \[arts.units.it\]](#)
- [19. Characterization of Sodium-Alginate-Based Hydrogels | Encyclopedia MDPI \[encyclopedia.pub\]](#)
- [20. Characterization of Sodium Alginate Hydrogels Reinforced with Nanoparticles of Hydroxyapatite for Biomedical Applications - PMC \[pmc.ncbi.nlm.nih.gov\]](#)
- [21. Effects of M/G Ratios of Sodium Alginate on Physicochemical Stability and Calcium Release Behavior of Pickering Emulsion Stabilized by Calcium Alginate - PMC \[pmc.ncbi.nlm.nih.gov\]](#)
- [22. Characterization at 25 °C of Sodium Hyaluronate in Aqueous Solutions Obtained by Transport Techniques \[mdpi.com\]](#)
- To cite this document: BenchChem. [Physical properties of sodium L-gulonate in solution]. BenchChem, [2026]. [Online PDF]. Available at: [\[https://www.benchchem.com/product/b12373610/docs#physical-properties-of-sodium-l-gulonate-in-solution\]](https://www.benchchem.com/product/b12373610/docs#physical-properties-of-sodium-l-gulonate-in-solution)

Disclaimer & Data Validity:

The information provided in this document is for Research Use Only (RUO) and is strictly not intended for diagnostic or therapeutic procedures. While BenchChem strives to provide accurate protocols, we make no warranties, express or implied, regarding the fitness of this product for every specific experimental application.

Technical Support: The protocols provided are for reference purposes. Unsure if this reagent suits your experiment?

Need Industrial/Bulk Grade? [Request Custom Synthesis Quote](#)

BenchChem

Our mission is to be the trusted global source of essential and advanced chemicals, empowering scientists and researchers to drive progress in science and industry.

Contact

Address: 3281 E Guasti Rd
Ontario, CA 91761, United States
Phone: (601) 213-4426
Email: info@benchchem.com

[Contact our Ph.D. Support Team for a compatibility check](#)