

Validating dGTP-15N5 as an Internal NMR Reference & Environmental Probe

Author: BenchChem Technical Support Team. **Date:** April 2026

Compound of Interest

Compound Name: *dGTP-15N5 (dilithium)*

Cat. No.: *B12372124*

[Get Quote](#)

Executive Summary

In high-resolution biomolecular NMR, precise chemical shift referencing is non-negotiable. While the IUPAC-recommended "Unified Scale" (indirect referencing via

ratios) is the gold standard for

N, it suffers from a critical blind spot: it is mathematically derived, not experimentally observed. It cannot account for local sample variations (pH, ionic strength, magnetic susceptibility) that subtly warp the spectral landscape.

This guide validates 2'-Deoxyguanosine-5'-triphosphate labeled with

N (dGTP-

N

) not merely as a passive ruler, but as an active internal comparator.^[1] Unlike inert external standards (e.g., liquid NH

in a capillary), dGTP-

N

shares the exact solvated environment of your analyte. Its validation as a standard relies on its dual capacity: to provide sharp, distinct resonance frequencies for spectral alignment and to act as a sensitive reporter of sample integrity (pH and metal ion consistency).

Part 1: The Challenge of N Referencing

To understand why dGTP-

N

is necessary, we must first dissect the limitations of current methodologies.

Feature	Indirect Referencing (IUPAC)	External Standard (Coaxial)	Internal dGTP-N
Method	Calculated from H (DSS/TSP) using ratio (0.101329118). [1]	Capillary insert with NH Cl or MeNO .[1]	Spiked directly into the sample.
Accuracy	High, assuming perfect temperature calibration and linearity.[1]	Moderate; suffers from bulk magnetic susceptibility (BMS) errors.	Highest; experiences identical B and susceptibility.[1]
Environmental Feedback	None. Blind to pH or salt errors.	None. Isolated from sample matrix.	Active. Shifts respond to pH/Mg , confirming buffer conditions.
Spectral Overlap	N/A (Virtual).	None (Distinct region).	Possible (Requires pre-screening).[1]
Safety	Safe.	Risk of breakage/leakage.[1]	Safe (Biologically compatible).[1]

The Core Problem: Indirect referencing assumes your spectrometer's temperature calibration is absolute. A 0.5 K error can introduce significant phase and shift errors in large protein

complexes.^[1] dGTP-

N

provides an empirical "truth" point within the tube.

Part 2: Technical Profile of the Candidate

Compound: 2'-Deoxyguanosine-5'-triphosphate (

N

) Isotopic Enrichment: >98%

N at N1, N2, N3, N7, N9. Key Resonance Markers (Approximate relative to liq. NH

):

- N7 (~230-250 ppm): Highly sensitive to protonation and metal coordination (Mg

).^[1]

- N1 (~140-150 ppm): Sensitive to pH (pKa ~9.^[1]²) and hydrogen bonding.^[1]

- NH

(N2): Often exchange-broadened; useful for assessing exchange regimes.^[1]

Suitability:

- Ideal for: Protein-DNA complexes, nucleotide-binding proteins (GTPases), and verifying buffer pH in situ.
- Contraindications: Samples with active GTPases (hydrolysis risk) or severe spectral crowding in the nucleotide region.

Part 3: Experimental Validation Protocol

This protocol is designed to be a self-validating system. You do not simply "add and measure"; you perform a Zero-Point Check to calibrate the standard itself against your buffer conditions.

^[1]

Phase 1: The Zero-Point Calibration (The "Golden Sample")

Goal: Establish the exact chemical shift of dGTP-

N

in your specific buffer, referenced to IUPAC standards.

- Buffer Prep: Prepare 500

L of your target NMR buffer (e.g., 20 mM Sodium Phosphate, pH 6.5, 100 mM NaCl).

- Internal Reference: Add 0.5 mM DSS (Sodium trimethylsilylpropanesulfonate).
- Analyte: Add 0.5 mM dGTP-

N

.[\[1\]](#)

- Acquisition:

- Run 1D

H with water suppression. Calibrate DSS methyl signal to 0.000 ppm.

- Run 1D

N or 2D

H-

N HSQC.

- Calculation:

- Calculate the theoretical 0 ppm for

N using the IUPAC

ratio (

N/

H = 0.101329118).

- Measure the observed shift of dGTP N7 and N1.
- Result: You now have a "Standard Value" for dGTP in your buffer (e.g., ppm).

Phase 2: The Experimental Application

Goal: Use dGTP as the internal anchor for your biological sample.

- Sample Prep: Prepare your protein/RNA sample in the exact same buffer batch as Phase 1.
- Spike-in: Add dGTP-

N

(0.1 - 0.2 mM).^[1] Note: Keep concentration low to avoid aggregation or competitive binding.

- Acquisition: Acquire your 2D/3D datasets.
- Alignment:
 - Instead of relying on the spectrometer's indirect calculation, find the dGTP N7 peak.
 - Set its value to the "Standard Value" determined in Phase 1 (e.g., 241.52 ppm).
 - This automatically corrects for minor temperature drifts or lock-solvent variations between samples.

Part 4: Visualization of Logic & Workflows

Diagram 1: The Validation Workflow

This flowchart illustrates the decision-making process for validating dGTP as a standard for a new sample.

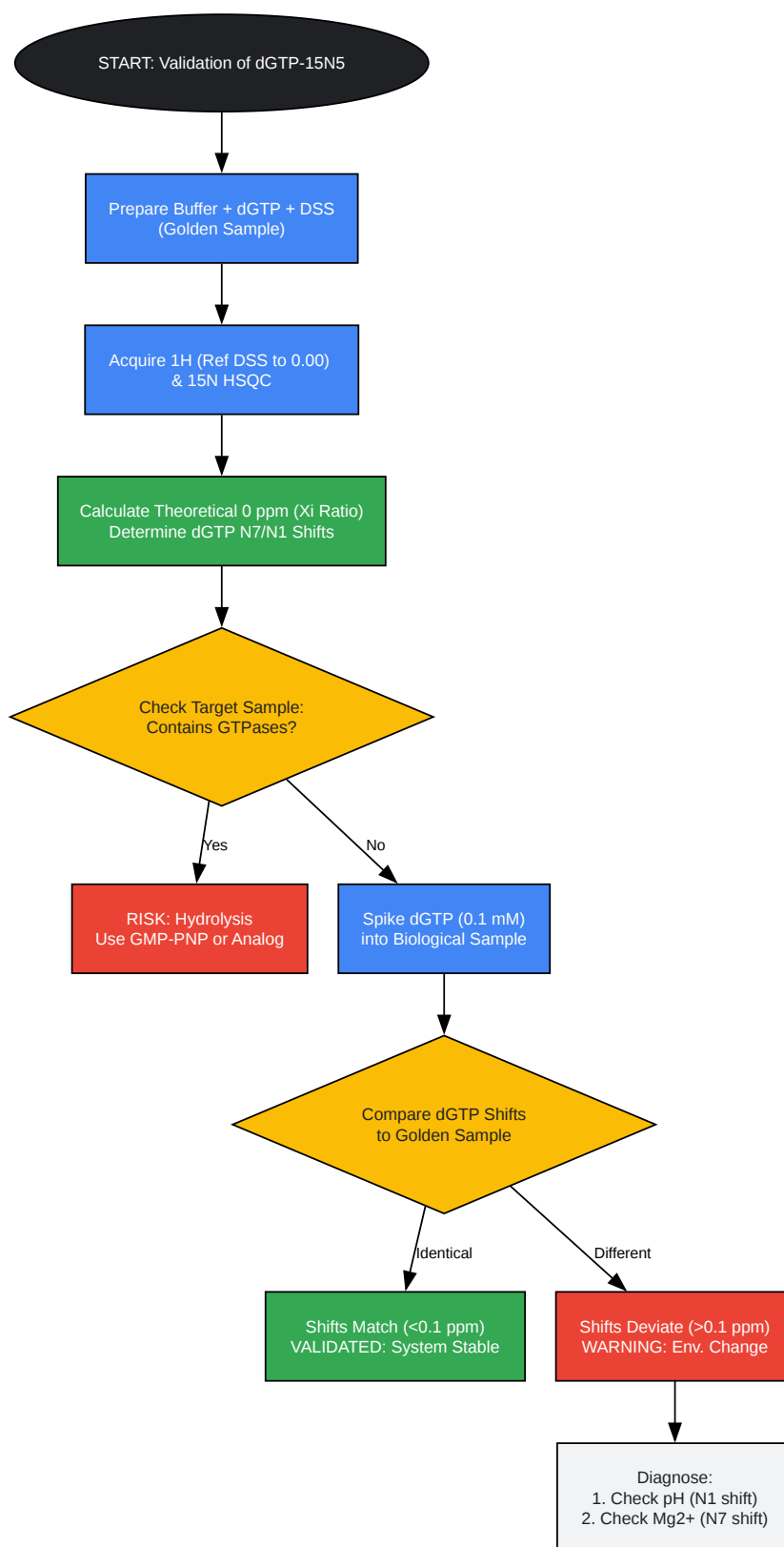

[Click to download full resolution via product page](#)

Caption: Workflow for establishing dGTP-15N5 as a reference. The "Golden Sample" step bridges the gap between IUPAC definitions and experimental utility.

Diagram 2: Interpreting dGTP Spectral Feedback

dGTP is an active probe.[1] This diagram helps you interpret why the standard might have shifted, turning a potential error into data.

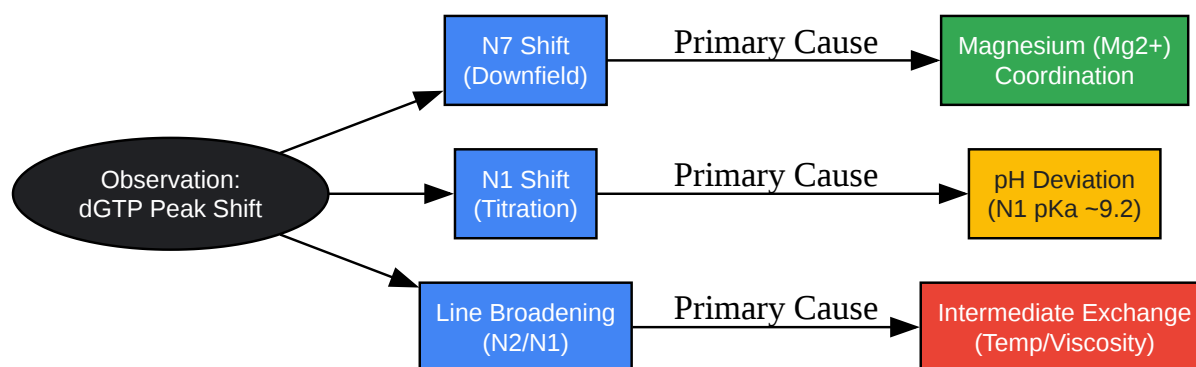

[Click to download full resolution via product page](#)

Caption: Diagnostic logic for dGTP-15N5. Unlike inert standards, dGTP shifts reveal changes in metal ion concentration (Mg²⁺) and pH.

Part 5: Scientific Integrity & Troubleshooting

1. The Magnesium Effect (Causality)

You must control for Mg

. In the presence of Mg

, the N7 signal of guanosine shifts significantly (often 1-2 ppm) due to inner-sphere coordination or electrostatic effects on the phosphate backbone transmitted to the base.

- Validation Step: If your protein requires Mg

, ensure your "Golden Sample" calibration (Phase 1) includes the exact same MgCl concentration.

2. The Hydrolysis Trap

dGTP is a high-energy molecule.[1] In the presence of catalytic impurities or extreme pH, it hydrolyzes to dGDP/dGMP, which have distinct chemical shifts.

- QC Marker: Monitor the 1D

P spectrum if possible. Appearance of inorganic phosphate (Pi) indicates standard degradation.[1]

- Alternative: If hydrolysis is observed, switch to GMP-PNP-

N, a non-hydrolyzable analog, though this requires a separate calibration curve.

3. Concentration & Sensitivity

N has a low gyromagnetic ratio.[1][2] While dGTP is enriched, using it at <100

M may require excessive scans for 1D calibration.[1]

- Recommendation: Use 2D

H-

N HSQC for referencing. It is more sensitive and resolves the N1-H1 and N2-H2 correlations clearly, avoiding overlap with protein amides (which usually sit at 100-135 ppm, while N1 is ~145+ ppm and N7 is not protonated/visible in HSQC without specific sequences).

Correction: N7 is not visible in standard HSQC; use N1-H1 correlations for alignment.

References

- Harris, R. K., et al. (2001). NMR nomenclature.[1] Nuclear spin properties and conventions for chemical shifts (IUPAC Recommendations 2001).[1] Pure and Applied Chemistry. [[Link](#)]
- Markley, J. L., et al. (1998). Recommendations for the presentation of NMR structures of proteins and nucleic acids (IUPAC Recommendations 1998). Pure and Applied Chemistry. [[Link](#)]
- Wishart, D. S., et al. (1995).

H,

C and

N chemical shift referencing in biomolecular NMR. Journal of Biomolecular NMR. [[Link](#)]

- Biological Magnetic Resonance Data Bank (BMRB). Chemical Shift Statistics.[1] [[Link](#)]
- Cortecnet. Stable Isotopes for NMR - Nucleotide Products.[1] [[Link](#)]

Need Custom Synthesis?

BenchChem offers custom synthesis for rare earth carbides and specific isotopic labeling.

Email: info@benchchem.com or [Request Quote Online](#).

Sources

- 1. [Stable Isotopes for NMR & MS \[cortecnet.com\]](#)
- 2. [Nitrogen-15 nuclear magnetic resonance spectroscopy - Wikipedia \[en.wikipedia.org\]](#)
- To cite this document: BenchChem. [Validating dGTP-15N5 as an Internal NMR Reference & Environmental Probe]. BenchChem, [2026]. [Online PDF]. Available at: [<https://www.benchchem.com/product/b12372124/docs#validating-dgtp-15n5-as-an-internal-nmr-reference-environmental-probe>]

Disclaimer & Data Validity:

The information provided in this document is for Research Use Only (RUO) and is strictly not intended for diagnostic or therapeutic procedures. While BenchChem strives to provide accurate protocols, we make no warranties, express or implied, regarding the fitness of this product for every specific experimental setup.

Technical Support: The protocols provided are for reference purposes. Unsure if this reagent suits your experiment?

Need Industrial/Bulk Grade? [Request Custom Synthesis Quote](#)

BenchChem

Our mission is to be the trusted global source of essential and advanced chemicals, empowering scientists and researchers to drive progress in science and industry.

Contact

Address: 3281 E Guasti Rd

Ontario, CA 91761, United States

Phone: (601) 213-4426

Email: info@benchchem.com

[Contact our Ph.D. Support Team for a compatibility check](#)