

Technical Support Center: Minimizing the Off-Target Activity of Nec-1

Author: BenchChem Technical Support Team. **Date:** April 2026

Compound of Interest

Compound Name: *Necrosis inhibitor 2*

Cat. No.: *B12372035*

[Get Quote](#)

This technical support center provides researchers, scientists, and drug development professionals with guidance on the proper use of Necrostatin-1 (Nec-1) and strategies to minimize its off-target activities.

Frequently Asked Questions (FAQs)

Q1: What is Nec-1 and what is its primary mechanism of action?

Necrostatin-1 (Nec-1) is a potent and specific small-molecule inhibitor of Receptor-Interacting serine/threonine-Protein Kinase 1 (RIPK1).[1] RIPK1 is a key regulator of necroptosis, a form of programmed cell death.[2][3] Nec-1 binds to a hydrophobic pocket in the kinase domain of RIPK1, locking it in an inactive conformation.[1] This inhibition of RIPK1's kinase activity prevents the downstream signaling cascade that leads to necroptosis.[1][2] Specifically, it blocks the autophosphorylation of RIPK1, which is crucial for the recruitment and phosphorylation of RIPK3 and the subsequent formation of the necrosome complex with Mixed Lineage Kinase Domain-Like protein (MLKL).[2]

Q2: What are the known off-target effects of Nec-1?

The most well-characterized off-target effect of Nec-1 is the inhibition of indoleamine 2,3-dioxygenase (IDO), an immunomodulatory enzyme.^{[2][4]} This was discovered because Nec-1 is identical to a previously identified IDO inhibitor called methyl-thiohydantoin-tryptophan (MTH-Trp).^{[2][4]} Additionally, some studies have reported other potential off-target effects, including modulation of JNK and Erk signaling, inhibition of PKA-C β , and an independent role in preventing ferroptosis.^{[5][6][7]} It has also been shown to induce apoptosis in neutrophils.^[8]

Q3: How can I control for the off-target effects of Nec-1 in my experiments?

To ensure that the observed effects in your experiments are due to the inhibition of RIPK1-mediated necroptosis and not off-target activities, several control experiments are crucial:

- **Use of Nec-1s:** Necrostatin-1s (Nec-1s), a stable analog of Nec-1, is a more specific RIPK1 inhibitor that does not inhibit IDO.^{[4][9]} It is considered a superior alternative to Nec-1 for in vivo studies due to its improved metabolic stability and specificity.^{[2][10]}
- **Use of Nec-1i (with caution):** Necrostatin-1 inactive (Nec-1i) is often used as a negative control. However, it's important to note that while it is significantly less potent in inhibiting RIPK1, it still inhibits IDO.^{[4][11][12]} At high concentrations, Nec-1i can exhibit biological activity, potentially confounding results.^{[4][9]} Therefore, it should be used at appropriate concentrations and the results interpreted with caution.
- **Genetic approaches:** The most definitive way to confirm that the observed phenotype is RIPK1-dependent is to use genetic approaches such as siRNA-mediated knockdown or knockout of RIPK1.^{[6][7]}
- **Rescue experiments:** If possible, perform rescue experiments by reintroducing a wild-type or kinase-dead mutant of RIPK1 to confirm that the effect of Nec-1 is specifically mediated through its kinase activity.

Troubleshooting Guide

Problem	Possible Cause	Recommended Solution
Inconsistent or unexpected results with Nec-1.	Off-target effects of Nec-1, particularly IDO inhibition.	1. Switch to the more specific RIPK1 inhibitor, Nec-1s, which does not inhibit IDO. 2. Include Nec-1i as a control, being mindful of its own potential effects at higher concentrations. 3. Confirm findings using genetic knockdown or knockout of RIPK1.
Nec-1 shows an effect, but RIPK1 knockdown/knockout does not.	The observed effect is likely due to an off-target activity of Nec-1, independent of RIPK1.	1. Investigate other potential off-targets of Nec-1 (e.g., IDO, JNK, Erk, PKA-C β). 2. Consider if the observed phenotype could be related to the induction of apoptosis or inhibition of ferroptosis.
Difficulty interpreting in vivo results with Nec-1.	Poor metabolic stability and off-target effects of Nec-1 can complicate in vivo studies. [2] [10]	1. Use Nec-1s, which has improved metabolic stability and specificity for in vivo experiments. [2] 2. Carefully titrate the dose of Nec-1 and include appropriate controls (vehicle, Nec-1i).
Nec-1i, the "inactive" control, shows biological activity.	Nec-1i is not completely inactive; it inhibits IDO and can have RIPK1-independent effects at higher concentrations. [4] [9]	1. Use the lowest effective concentration of Nec-1i. 2. Acknowledge the potential for Nec-1i's own biological activity in the interpretation of your data. 3. Prioritize the use of Nec-1s and genetic controls for more definitive conclusions.

Quantitative Data Summary

Table 1: Comparison of Nec-1 and its Analogs

Compound	Primary Target	IDO Inhibition	Metabolic Stability	Recommended Use
Nec-1	RIPK1	Yes	Low	In vitro studies with appropriate controls.
Nec-1i	(Inactive for RIPK1)	Yes	-	Negative control (use with caution). [4] [11] [12]
Nec-1s	RIPK1	No	High	In vitro and in vivo studies requiring high specificity. [2] [4] [9]

Table 2: Reported Potency of Nec-1 Analogs

Compound	Inhibition of human RIPK1 in vitro (relative to Nec-1)	Potency in mouse necroptosis assay (relative to Nec-1)
Nec-1	1x	1x
Nec-1i	~100x less effective	~10x less potent
Nec-1s	Similar to Nec-1	Similar to Nec-1

Data summarized from Takahashi et al., 2012.[\[4\]](#)[\[9\]](#)

Experimental Protocols

Protocol 1: In Vitro Necroptosis Inhibition Assay

- **Cell Seeding:** Plate cells (e.g., L929, HT-29) in a 96-well plate at a density of $1-5 \times 10^4$ cells/well and allow them to adhere overnight.
- **Pre-treatment with Inhibitors:** Pre-incubate the cells with various concentrations of Nec-1, Nec-1s, or Nec-1i for 1-2 hours. Include a vehicle control (e.g., DMSO).
- **Induction of Necroptosis:** Induce necroptosis by adding a combination of TNF- α (e.g., 10-100 ng/mL), a Smac mimetic (e.g., 100 nM), and a pan-caspase inhibitor (e.g., z-VAD-fmk, 20 μ M).
- **Incubation:** Incubate the plate for 4-24 hours, depending on the cell line and experimental conditions.
- **Cell Viability Assessment:** Measure cell viability using a standard assay such as MTT, CellTiter-Glo, or by staining with propidium iodide and analysis by flow cytometry.
- **Data Analysis:** Plot cell viability against inhibitor concentration to determine the EC₅₀ for each compound.

Protocol 2: Western Blot for RIPK1 Phosphorylation

- **Cell Treatment:** Treat cells with the necroptosis-inducing stimulus in the presence or absence of Nec-1 or its analogs as described in Protocol 1.
- **Cell Lysis:** Lyse the cells in RIPA buffer supplemented with protease and phosphatase inhibitors.
- **Protein Quantification:** Determine the protein concentration of each lysate using a BCA or Bradford assay.
- **SDS-PAGE and Western Blotting:** Separate equal amounts of protein on an SDS-PAGE gel and transfer to a PVDF membrane.
- **Antibody Incubation:** Probe the membrane with a primary antibody specific for phosphorylated RIPK1 (e.g., Ser166). Subsequently, probe with a primary antibody for total RIPK1 and a loading control (e.g., GAPDH, β -actin).

- Detection: Use an appropriate HRP-conjugated secondary antibody and a chemiluminescent substrate to detect the protein bands.
- Analysis: Quantify the band intensities to determine the ratio of phosphorylated RIPK1 to total RIPK1.

Visualizations

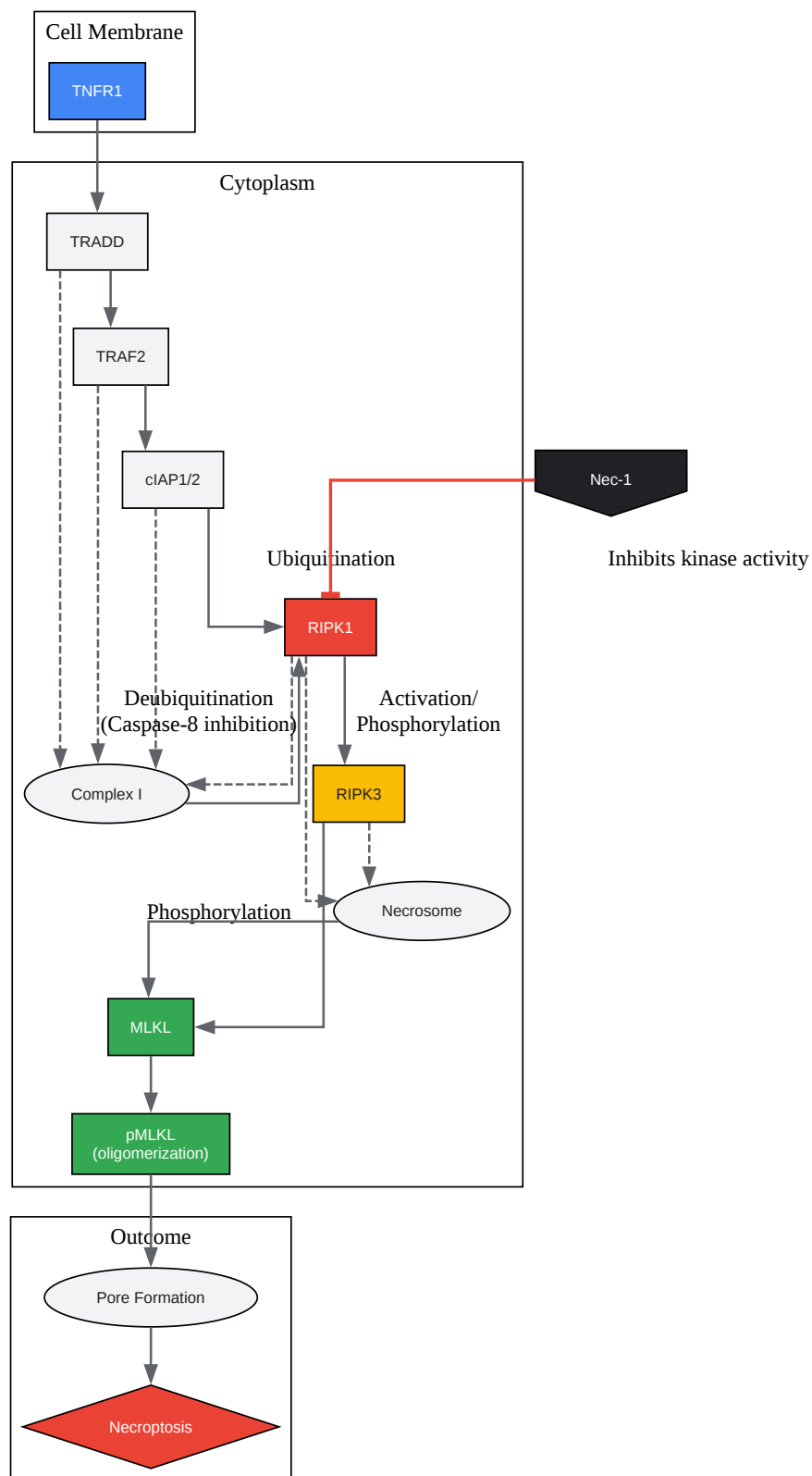

[Click to download full resolution via product page](#)

Caption: Necroptosis signaling pathway and the inhibitory action of Nec-1.

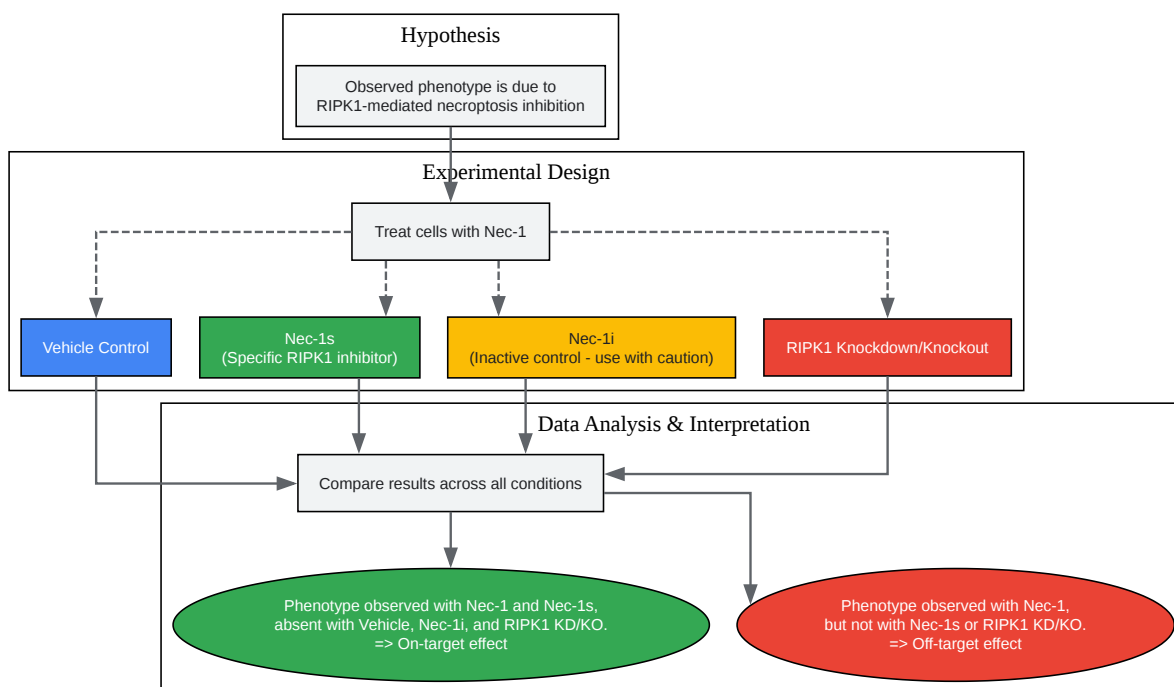

[Click to download full resolution via product page](#)

Caption: Recommended experimental workflow to validate Nec-1's on-target effects.

Need Custom Synthesis?

BenchChem offers custom synthesis for rare earth carbides and specific isotopic labeling.

Email: info@benchchem.com or [Request Quote Online](#).

References

- [1. invivogen.com \[invivogen.com\]](https://www.invivogen.com)
- [2. Necrostatin-1 and necroptosis inhibition: Pathophysiology and therapeutic implications - PMC \[pmc.ncbi.nlm.nih.gov\]](https://pubmed.ncbi.nlm.nih.gov/21192/)
- [3. researchgate.net \[researchgate.net\]](https://www.researchgate.net)
- [4. Necrostatin-1 analogues: critical issues on the specificity, activity and in vivo use in experimental disease models - PubMed \[pubmed.ncbi.nlm.nih.gov\]](https://pubmed.ncbi.nlm.nih.gov/21192/)
- [5. mdpi.com \[mdpi.com\]](https://www.mdpi.com)
- [6. RIP1-Dependent and Independent Effects of Necrostatin-1 in Necrosis and T Cell Activation | PLOS One \[journals.plos.org\]](https://doi.org/10.1371/journal.plosone.0161111)
- [7. RIP1-Dependent and Independent Effects of Necrostatin-1 in Necrosis and T Cell Activation - PMC \[pmc.ncbi.nlm.nih.gov\]](https://pubmed.ncbi.nlm.nih.gov/21192/)
- [8. Necrostatin-1 enhances the resolution of inflammation by specifically inducing neutrophil apoptosis - PMC \[pmc.ncbi.nlm.nih.gov\]](https://pubmed.ncbi.nlm.nih.gov/21192/)
- [9. "Necrostatin-1 analogues: critical issues on the specificity, activity " by N Takahashi, L Duprez et al. \[jdc.jefferson.edu\]](https://pubmed.ncbi.nlm.nih.gov/21192/)
- [10. Activity and specificity of necrostatin-1, small-molecule inhibitor of RIP1 kinase - PMC \[pmc.ncbi.nlm.nih.gov\]](https://pubmed.ncbi.nlm.nih.gov/21192/)
- [11. caymanchem.com \[caymanchem.com\]](https://www.caymanchem.com)
- [12. Necrostatin-1 Inactive Control - Biochemicals - CAT N°: 21192 \[bertin-bioreagent.com\]](https://www.bertin-bioreagent.com)
- To cite this document: BenchChem. [Technical Support Center: Minimizing the Off-Target Activity of Nec-1]. BenchChem, [2026]. [Online PDF]. Available at: [\[https://www.benchchem.com/product/b12372035/docs#technical-support-center-minimizing-the-off-target-activity-of-nec-1\]](https://www.benchchem.com/product/b12372035/docs#technical-support-center-minimizing-the-off-target-activity-of-nec-1)

Disclaimer & Data Validity:

The information provided in this document is for Research Use Only (RUO) and is strictly not intended for diagnostic or therapeutic procedures. While BenchChem strives to provide accurate protocols, we make no warranties, express or implied, regarding the fitness of this product for every specific experimental setup.

Technical Support: The protocols provided are for reference purposes. Unsure if this reagent suits your experiment?

Need Industrial/Bulk Grade? [Request Custom Synthesis Quote](#)

BenchChem

Our mission is to be the trusted global source of essential and advanced chemicals, empowering scientists and researchers to drive progress in science and industry.

Contact

Address: 3281 E Guasti Rd
Ontario, CA 91761, United States
Phone: (601) 213-4426
Email: info@benchchem.com

[Contact our Ph.D. Support Team for a compatibility check](#)