

Benchmarking Trehalose C14: A Comparative Performance Analysis for Researchers

Author: BenchChem Technical Support Team. **Date:** April 2026

Compound of Interest

Compound Name: Trehalose C14

Cat. No.: B12372939

[Get Quote](#)

In the landscape of scientific research and drug development, the disaccharide trehalose has garnered significant attention for its multifaceted applications, ranging from a cryoprotectant to a metabolic probe. When labeled with Carbon-14 (^{14}C), "**Trehalose C14**" becomes a powerful tool for tracing metabolic pathways. This guide provides a comprehensive performance comparison of **Trehalose C14** against existing methods in its two primary applications: metabolic labeling and cryopreservation.

Part 1: Trehalose C14 as a Metabolic Probe

Radiolabeled trehalose, particularly ^{14}C -trehalose, is instrumental in elucidating metabolic activities, most notably in pathogens like *Mycobacterium tuberculosis* (Mtb). Its performance is benchmarked by its efficiency of uptake and incorporation into cellular components compared to other radiolabeled precursors.

Comparative Data Summary

Radioprobe	Application	Organism	Key Findings	Reference
¹⁴ C-Trehalose	Tracing trehalose metabolism and cell wall biosynthesis	Mycobacterium tuberculosis	Significant uptake and incorporation into trehalose monomycolate (TMM) and trehalose dimycolate (TDM), key components of the mycobacterial cell wall.[1]	[1]
¹⁴ C-Acetate	General fatty acid and lipid biosynthesis	Mycobacterium tuberculosis	Labels a broad range of fatty acids and lipids, including mycolic acids. Used as a comparative probe to confirm the identity of TMM and TDM labeled by ¹⁴ C-trehalose.[1]	[1]
¹⁴ C-Glycerol	Glycerolipid and central carbon metabolism	Mycobacterium tuberculosis	Used to measure general metabolic activity and uptake.[1]	
¹⁴ C-Glucose	Central carbon metabolism	Mycobacterium tuberculosis	Measures general glucose uptake and metabolism.	
¹³ C-Glucose	Stable isotope-based flux	Yeast	Enables measurement of	

analysis

carbon flux into
trehalose from
glycolysis or
gluconeogenesis
through LC-
MS/MS.

Experimental Protocol: Metabolic Labeling of *M. tuberculosis* with ^{14}C -Trehalose

This protocol is adapted from studies investigating trehalose uptake in *M. tuberculosis*.

- **Culture Preparation:** *M. tuberculosis* cultures are grown to mid-log phase in an appropriate broth medium.
- **Infection (for in-macrophage studies):** Macrophages are infected with *M. tuberculosis* at a specified multiplicity of infection.
- **Radiolabeling:** ^{14}C -trehalose is added to the culture medium (for in vitro studies) or the infected macrophage culture at a final concentration.
- **Incubation:** Cultures are incubated for a defined period (e.g., 24 hours) to allow for the uptake and metabolism of the ^{14}C -trehalose.
- **Cell Lysis and Fractionation:**
 - For in vitro cultures, cells are harvested, washed, and lysed.
 - For infected macrophages, the supernatant (extracellular fraction) is removed, macrophages are lysed, and bacteria are separated from the host cell cytoplasm by centrifugation.
- **Lipid Extraction:** Lipids are extracted from the bacterial pellets using a series of organic solvents (e.g., chloroform/methanol).
- **Analysis:** The extracted lipids are analyzed by thin-layer chromatography (TLC) and autoradiography to visualize the incorporation of ^{14}C into specific glycolipids like TMM and

TDM.

Visualization of Trehalose Metabolism in Mycobacteria

The following diagram illustrates the pathway of trehalose incorporation into the mycobacterial cell wall, a process effectively traced using ^{14}C -trehalose.

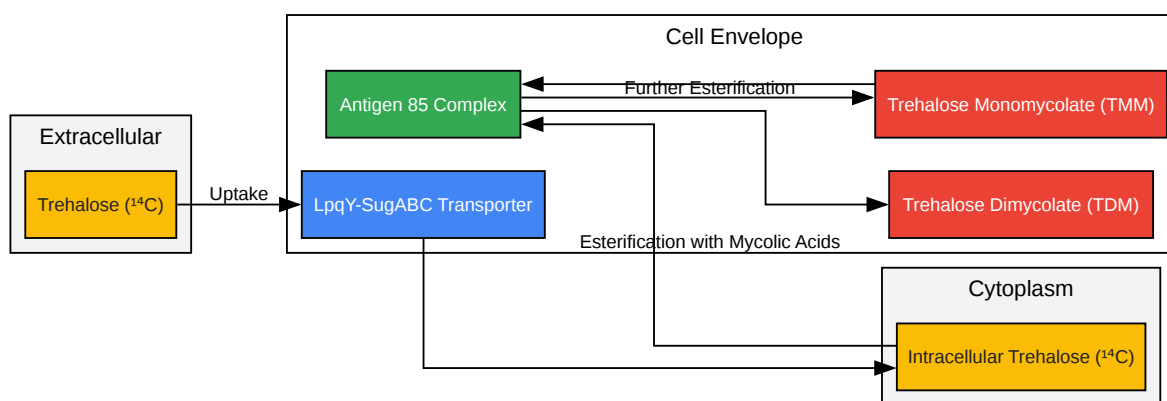

[Click to download full resolution via product page](#)

Caption: Pathway of ^{14}C -trehalose uptake and incorporation in mycobacteria.

Part 2: Trehalose as a Cryoprotectant

Trehalose is widely used to protect cells and biological molecules from damage during freezing. Its performance is often compared to traditional cryoprotectants like glycerol and dimethyl sulfoxide (DMSO), as well as other sugars such as sucrose and raffinose.

Comparative Data Summary: Sperm Cryopreservation

Cryoprotectant	Organism	Parameter	Key Findings	Reference
Trehalose	Mouse Sperm	Post-thaw membrane integrity	7.5% trehalose with 6% glycerol yielded significantly better recovery of intact cells (48%) compared to raffinose (36%).	
Raffinose	Mouse Sperm	Post-thaw membrane integrity	Less effective than trehalose under the same conditions.	
Trehalose	Noble Scallop Sperm	Motility, Velocity	Less effective than 10% DMSO but significantly better than the control group.	
DMSO	Noble Scallop Sperm	Motility, Velocity	10% DMSO provided the best protection among all tested cryoprotectants.	
Glycerol	Boar Sperm	Motility, Viability	A combination of 3% glycerol with trehalose showed a better effect on total motility post-thaw.	

Comparative Data Summary: Stem Cell and Hepatocyte Cryopreservation

Cryoprotectant	Cell Type	Parameter	Key Findings	Reference
Trehalose + DMSO	Bovine Spermatogonial Stem Cells	Cell Recovery	200 mM trehalose + 20% DMSO improved recovery (19%) compared to DMSO alone (7%) or DMSO + sucrose (5%).	
Sucrose + DMSO	Bovine Spermatogonial Stem Cells	Cell Recovery	Less effective than the trehalose and DMSO combination.	
Trehalose + DMSO	Human Hepatocytes	Viability	200 mM trehalose added to 10% DMSO improved viability (63% vs. 47% for DMSO alone).	

Experimental Protocol: Cryopreservation of Mouse Sperm

This protocol is a generalized workflow based on comparative studies.

- **Cryoprotectant Preparation:** Prepare a cryoprotectant medium, for instance, a non-bicarbonate medium (NTP) containing 6% glycerol and 7.5% trehalose.
- **Equilibration:** Add the cryoprotectant to the sperm suspension. This can be done through serial dilution or, more effectively, through dialysis to minimize osmotic shock.

- Freezing: Aliquots of the sperm suspension in cryoprotectant are cooled in a controlled-rate freezer or by suspension in liquid nitrogen vapor before plunging into liquid nitrogen for storage.
- Thawing: Samples are rapidly thawed in a water bath at a controlled temperature (e.g., 37°C).
- Post-Thaw Analysis:
 - Motility Assessment: Sperm motility is evaluated using computer-assisted sperm analysis (CASA) or manual counting.
 - Membrane Integrity: Plasma membrane integrity is assessed using vital stains (e.g., SYBR-14/propidium iodide).
 - Fertilization Capacity: In vitro fertilization (IVF) is performed to determine the functional competence of the cryopreserved sperm.

Visualization of Cryopreservation Workflow

The following diagram outlines a typical experimental workflow for comparing cryoprotectants.

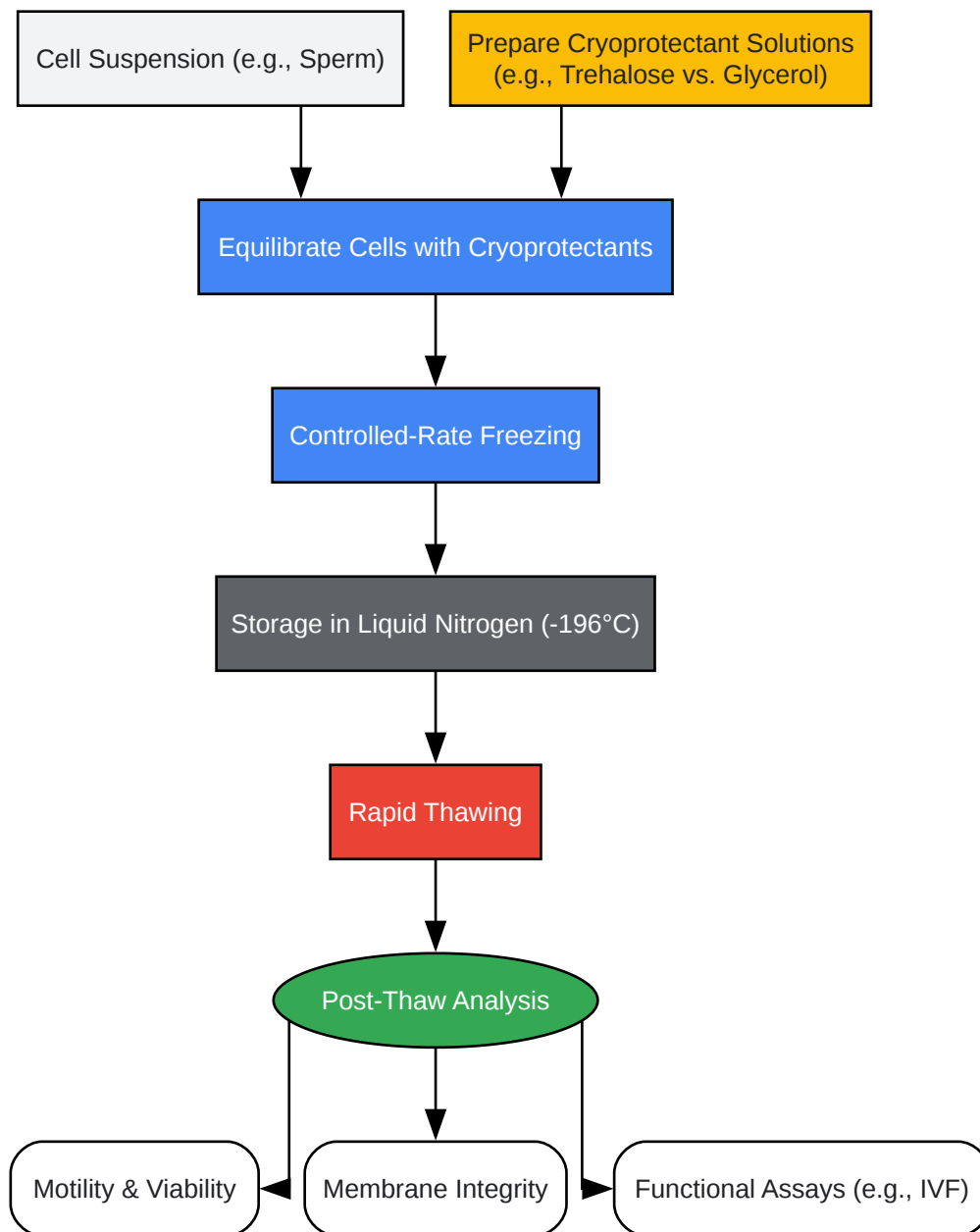

[Click to download full resolution via product page](#)

Caption: Experimental workflow for comparative cryopreservation studies.

Conclusion

As a metabolic probe, ^{14}C -trehalose offers high specificity for tracking the synthesis of essential cell wall components in organisms like *Mycobacterium tuberculosis*. Its performance is best benchmarked against broader metabolic labels like ^{14}C -acetate and ^{14}C -glucose, which help to confirm the specific pathways involving trehalose.

In cryopreservation, trehalose demonstrates significant efficacy, often outperforming other sugars like raffinose and sucrose, particularly when used in combination with a penetrating cryoprotectant like glycerol or DMSO. While it may not always surpass the effectiveness of high concentrations of traditional cryoprotectants like DMSO for all cell types, its lower toxicity and ability to stabilize membranes make it a critical component in optimizing cryopreservation protocols.

For researchers and drug development professionals, the choice of method depends on the specific application. ^{14}C -trehalose is an invaluable tool for targeted metabolic studies, while non-labeled trehalose is a high-performing and often essential component in the formulation of cryopreservation media.

Need Custom Synthesis?

BenchChem offers custom synthesis for rare earth carbides and specific isotopic labeling.

Email: info@benchchem.com or [Request Quote Online](#).

References

- [1. Uptake of unnatural trehalose analogs as a reporter for Mycobacterium tuberculosis - PMC \[pmc.ncbi.nlm.nih.gov\]](#)
- To cite this document: BenchChem. [Benchmarking Trehalose C14: A Comparative Performance Analysis for Researchers]. BenchChem, [2026]. [Online PDF]. Available at: [<https://www.benchchem.com/product/b12372939/docs#benchmarking-trehalose-c14-a-comparative-performance-analysis-for-researchers>]

Disclaimer & Data Validity:

The information provided in this document is for Research Use Only (RUO) and is strictly not intended for diagnostic or therapeutic procedures. While BenchChem strives to provide accurate protocols, we make no warranties, express or implied, regarding the fitness of this product for every specific experimental setup.

Technical Support: The protocols provided are for reference purposes. Unsure if this reagent suits your experiment?

Need Industrial/Bulk Grade? [Request Custom Synthesis Quote](#)

BenchChem

Our mission is to be the trusted global source of essential and advanced chemicals, empowering scientists and researchers to drive progress in science and industry.

Contact

Address: 3281 E Guasti Rd
Ontario, CA 91761, United States
Phone: (601) 213-4426
Email: info@benchchem.com

[Contact our Ph.D. Support Team for a compatibility check](#)