

Application Notes and Protocols for (Rac)-D3S-001: In Vitro Experimental Guide

Author: BenchChem Technical Support Team. **Date:** April 2026

Compound of Interest

Compound Name: (Rac)-D3S-001

Cat. No.: B12372128

[Get Quote](#)

Audience: Researchers, scientists, and drug development professionals.

Introduction

(Rac)-D3S-001 is a next-generation, orally bioavailable, covalent inhibitor of KRAS G12C, a common oncogenic mutation found in various solid tumors.[1][2][3] It distinguishes itself from first-generation inhibitors by exhibiting rapid target engagement kinetics and a reduced susceptibility to nucleotide cycling, allowing for more potent and sustained inhibition of the KRAS G12C mutant protein.[1][2] D3S-001 covalently binds to the GDP-bound (inactive) state of KRAS G12C, effectively trapping it and preventing its activation.[1][4][5] This leads to the suppression of downstream signaling pathways, primarily the MAPK pathway, thereby inhibiting tumor cell proliferation and survival.[1] Preclinical studies have demonstrated its robust anti-tumor activity in various cancer cell lines and xenograft models.[1][2][6]

These application notes provide detailed protocols for key in vitro experiments to characterize the activity of **(Rac)-D3S-001** and similar KRAS G12C inhibitors.

Data Presentation

Table 1: In Vitro Anti-proliferative Activity of D3S-001 in KRAS G12C Mutant Cancer Cell Lines

Cell Line	Cancer Type	2D IC ₅₀ (nM)	3D IC ₅₀ (nM)
NCI-H358	Non-Small Cell Lung Cancer	1.2	3.5
MIA PaCa-2	Pancreatic Cancer	2.5	8.1
SW837	Colorectal Cancer	3.1	10.2

Note: IC₅₀ values are representative and may vary based on experimental conditions. Data is a synthesized representation from preclinical findings.

Table 2: Inhibition of KRAS G12C Signaling by D3S-001

Assay	Cell Line	D3S-001 Concentration	% Inhibition of pERK
pERK HTRF	NCI-H358	10 nM	85%
pERK HTRF	NCI-H358	100 nM	>95%
pERK HTRF	MIA PaCa-2	10 nM	82%
pERK HTRF	MIA PaCa-2	100 nM	>95%

Note: Data is a synthesized representation from preclinical findings.

Mandatory Visualizations

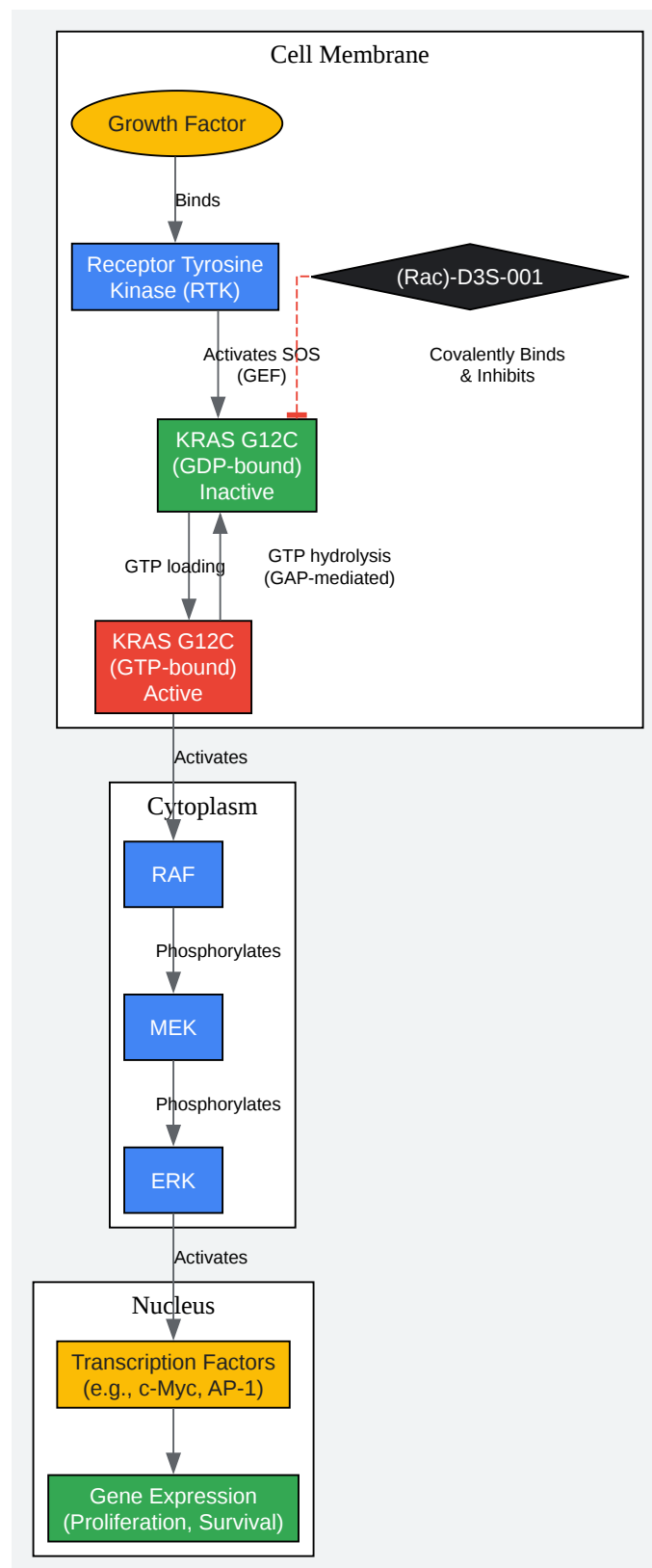

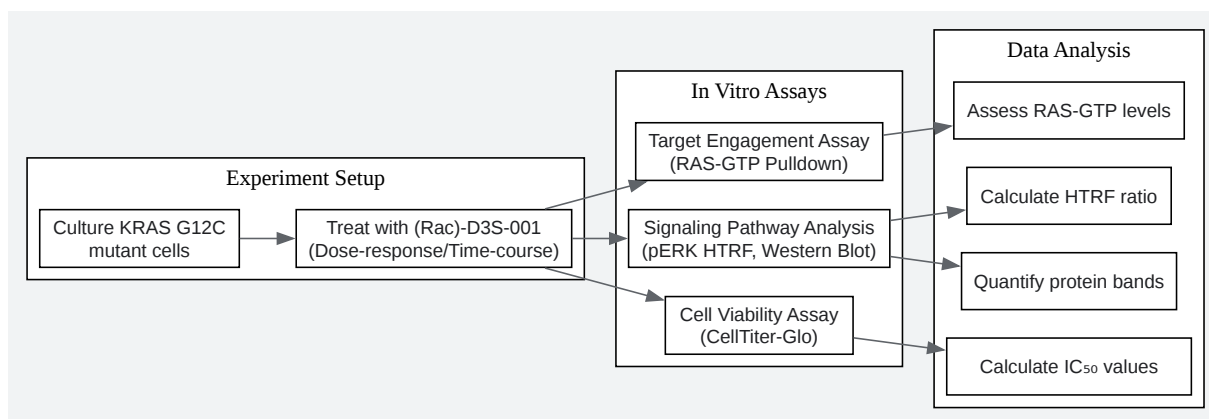

[Click to download full resolution via product page](#)

Need Custom Synthesis?

BenchChem offers custom synthesis for rare earth carbides and specific isotopic labeling.

Email: info@benchchem.com or [Request Quote Online](#).

References

- 1. [CellTiter-Glo® 3D Cell Viability Assay Protocol \[promega.kr\]](#)
- 2. [promega.com \[promega.com\]](#)
- 3. [ilexlife.com \[ilexlife.com\]](#)
- 4. [researchgate.net \[researchgate.net\]](#)
- 5. [benchchem.com \[benchchem.com\]](#)
- 6. [neweastbio.com \[neweastbio.com\]](#)
- To cite this document: BenchChem. [Application Notes and Protocols for (Rac)-D3S-001: In Vitro Experimental Guide]. BenchChem, [2026]. [Online PDF]. Available at: [\[https://www.benchchem.com/product/b12372128/docs#application-notes-and-protocols-for-rac-d3s-001-in-vitro-experimental-guide\]](https://www.benchchem.com/product/b12372128/docs#application-notes-and-protocols-for-rac-d3s-001-in-vitro-experimental-guide)

Disclaimer & Data Validity:

The information provided in this document is for Research Use Only (RUO) and is strictly not intended for diagnostic or therapeutic procedures. While BenchChem strives to provide accurate protocols, we make no warranties, express or implied, regarding the fitness of this product for every specific experimental setup.

Technical Support: The protocols provided are for reference purposes. Unsure if this reagent suits your experiment?

Need Industrial/Bulk Grade? [Request Custom Synthesis Quote](#)

BenchChem

Our mission is to be the trusted global source of essential and advanced chemicals, empowering scientists and researchers to drive progress in science and industry.

Contact

Address: 3281 E Guasti Rd

Ontario, CA 91761, United States

Phone: (601) 213-4426

Email: info@benchchem.com

[Contact our Ph.D. Support Team for a compatibility check](#)