

Application Notes & Protocols: Development of Pseudolaroside B-Loaded Nanoparticles for Cancer Therapy

Author: BenchChem Technical Support Team. **Date:** April 2026

Compound of Interest

Compound Name: *Pseudolaroside B*

Cat. No.: *B12372517*

[Get Quote](#)

Audience: Researchers, scientists, and drug development professionals.

Introduction: **Pseudolaroside B** (PLB), also known as Pseudolaric Acid B, is a diterpenoid isolated from the root bark of *Pseudolarix kaempferi*. It has demonstrated significant anti-cancer activities across various cancer cell lines. PLB is known to induce apoptosis, cell cycle arrest, and inhibit cell migration and invasion through the modulation of multiple signaling pathways.[1][2] However, its clinical application can be limited by factors such as poor water solubility. Encapsulating PLB into nanoparticles, such as those made from biodegradable polymers like Poly(lactic-co-glycolic acid) (PLGA), offers a promising strategy to improve its bioavailability, stability, and therapeutic efficacy.[3][4]

These application notes provide a comprehensive overview and detailed protocols for the formulation, characterization, and evaluation of PLB-loaded nanoparticles.

Mechanism of Action of Pseudolaroside B

PLB exerts its anti-tumor effects by targeting several key cellular processes. Its primary mechanisms include the induction of apoptosis through both mitochondrial and other signaling

pathways, and cell cycle arrest at the G2/M phase.[\[1\]\[2\]](#)

- **Mitochondrial Apoptosis Pathway:** PLB upregulates the pro-apoptotic protein Bax while downregulating anti-apoptotic proteins like Bcl-2 and Bcl-xl.[\[1\]\[5\]](#) This shift promotes the release of cytochrome c from the mitochondria into the cytoplasm, which in turn activates caspase-9 and the executioner caspase-3, leading to apoptosis.[\[1\]\[6\]](#)
- **PI3K/AKT/mTOR Pathway Inhibition:** PLB has been shown to inhibit the phosphorylation of key proteins in the PI3K/AKT/mTOR signaling pathway, a critical pathway for cell survival and proliferation.[\[1\]](#)
- **Cell Cycle Arrest:** The compound induces G2/M phase cell cycle arrest, preventing cancer cells from dividing. This is often associated with the upregulation of tumor suppressor proteins p53 and p21.[\[1\]\[7\]](#)
- **Other Signaling Pathways:** PLB also influences other pathways, including the activation of JNK and AMPK, which are involved in cellular stress responses and apoptosis.[\[5\]\[8\]](#)

Signaling Pathway Diagram

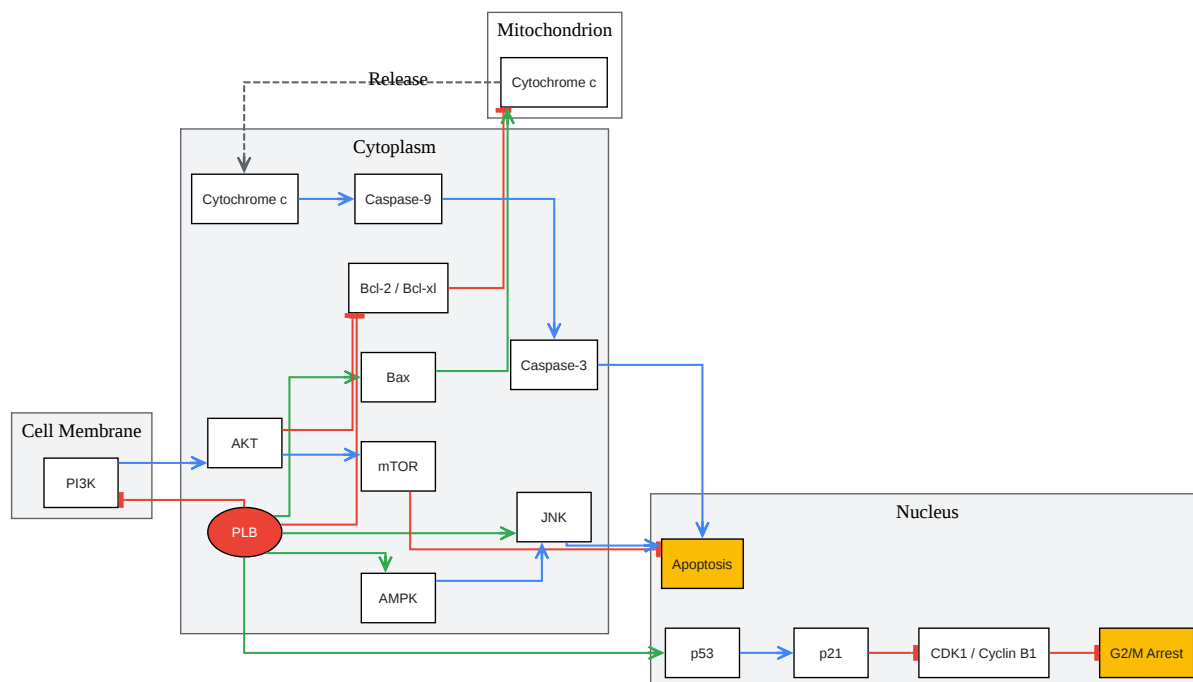

[Click to download full resolution via product page](#)

Caption: Signaling pathways modulated by **Pseudolaroside B (PLB)** in cancer cells.

Formulation of PLB-Loaded Nanoparticles

This section provides a protocol for formulating PLB-loaded PLGA nanoparticles using a single emulsion-solvent evaporation technique, a common method for encapsulating hydrophobic

drugs.[9][10]

Experimental Workflow

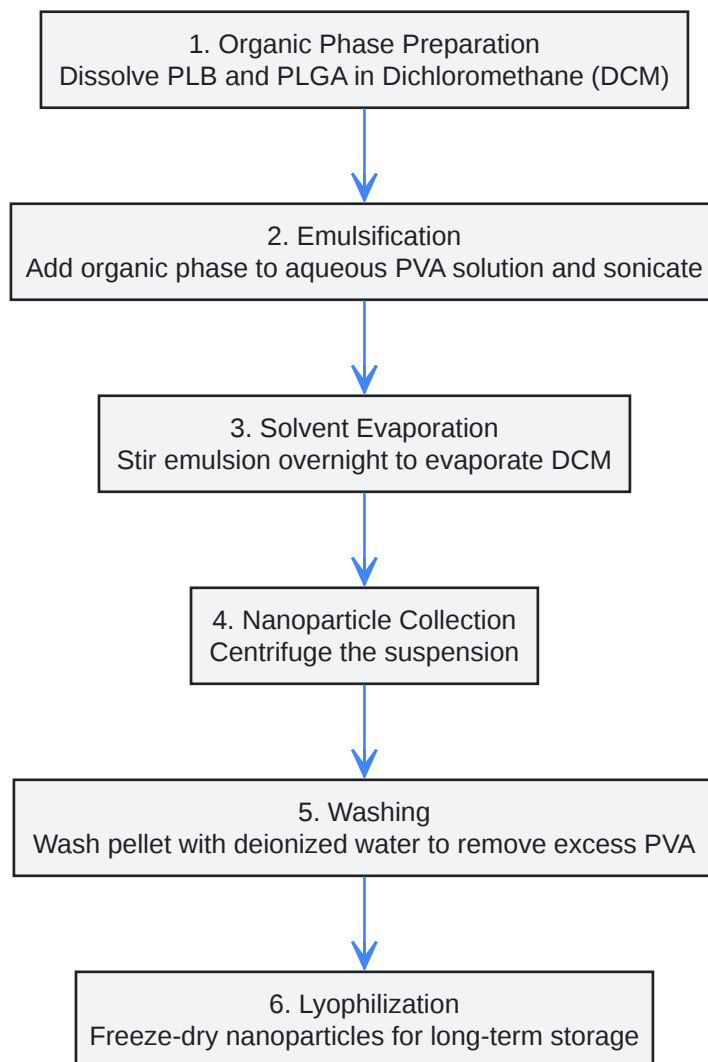

[Click to download full resolution via product page](#)

Caption: Workflow for PLB-loaded nanoparticle formulation.

Protocol 2.1: Preparation of PLB-PLGA Nanoparticles

Materials:

- **Pseudolaroside B (PLB)**
- Poly(lactic-co-glycolic acid) (PLGA, 50:50)

- Polyvinyl alcohol (PVA)
- Dichloromethane (DCM)
- Deionized water
- Probe sonicator
- Magnetic stirrer
- Centrifuge
- Lyophilizer

Method:

- Organic Phase: Dissolve 10 mg of PLB and 100 mg of PLGA in 2 mL of DCM.
- Aqueous Phase: Prepare a 1% (w/v) PVA solution in 20 mL of deionized water.
- Emulsification: Add the organic phase dropwise to the aqueous phase while stirring. Sonicate the mixture on an ice bath for 3 minutes (e.g., 40% amplitude, 10-second pulses) to form an oil-in-water (o/w) emulsion.
- Solvent Evaporation: Transfer the emulsion to a magnetic stirrer and stir at room temperature overnight to allow for the complete evaporation of DCM, leading to nanoparticle hardening.
- Collection: Centrifuge the nanoparticle suspension at 15,000 x g for 20 minutes at 4°C.
- Washing: Discard the supernatant and wash the nanoparticle pellet three times by resuspending in deionized water and centrifuging again to remove residual PVA and unencapsulated drug.
- Storage: Resuspend the final pellet in a small amount of deionized water containing a cryoprotectant (e.g., 2% trehalose) and lyophilize for 48 hours. Store the dried powder at -20°C.

Characterization of PLB-Loaded Nanoparticles

Proper characterization is crucial to ensure the quality, stability, and efficacy of the nanoparticle formulation.[\[11\]](#)[\[12\]](#)

Table 1: Key Characterization Parameters

Parameter	Method	Typical Expected Values	Purpose
Particle Size & PDI	Dynamic Light Scattering (DLS)	100 - 200 nm; PDI < 0.2	Determines size distribution and uniformity, affecting cellular uptake and biodistribution.
Zeta Potential	DLS / Electrophoretic Light Scattering	-15 to -30 mV	Indicates surface charge and colloidal stability.
Morphology	Transmission Electron Microscopy (TEM) / Scanning Electron Microscopy (SEM)	Spherical shape, smooth surface	Visual confirmation of size, shape, and surface characteristics. [12]
Drug Loading (DL)	High-Performance Liquid Chromatography (HPLC)	5 - 10%	Quantifies the amount of drug encapsulated relative to the nanoparticle weight.
Encapsulation Efficiency (EE)	High-Performance Liquid Chromatography (HPLC)	> 80%	Measures the percentage of the initial drug that is successfully encapsulated.
In Vitro Release	Dialysis Method with HPLC	Biphasic: Initial burst followed by sustained release	Evaluates the drug release profile over time under physiological conditions. [10]

Protocol 3.1: Particle Size and Zeta Potential

- Resuspend a small amount of lyophilized PLB-NPs in deionized water.
- Analyze the suspension using a DLS instrument (e.g., Malvern Zetasizer).
- Record the Z-average diameter for particle size and the Polydispersity Index (PDI).
- For Zeta Potential, use the same instrument with an appropriate folded capillary cell.

Protocol 3.2: Drug Loading and Encapsulation Efficiency

- Weigh a precise amount (e.g., 5 mg) of lyophilized PLB-NPs.
- Dissolve the nanoparticles in a suitable solvent (e.g., 1 mL of DCM or DMSO) to break them apart and release the drug.
- Evaporate the organic solvent and reconstitute the residue in the mobile phase for HPLC analysis.
- Quantify the PLB concentration using a pre-established calibration curve.
- Calculate DL and EE using the following formulas:
 - Drug Loading (%) = $(\text{Mass of drug in NPs} / \text{Mass of NPs}) \times 100$
 - Encapsulation Efficiency (%) = $(\text{Mass of drug in NPs} / \text{Initial mass of drug used}) \times 100$

In Vitro Efficacy Assessment

In vitro studies are essential to confirm that the formulated PLB-NPs retain their anti-cancer activity.^{[13][14]}

Protocol 4.1: Cell Viability (MTT Assay)

- Seed cancer cells (e.g., MDA-MB-231, HeLa) in a 96-well plate and allow them to adhere overnight.

- Treat the cells with varying concentrations of free PLB, PLB-NPs, and empty NPs (as a control) for 48-72 hours.
- Add MTT reagent to each well and incubate for 4 hours.
- Add solubilization solution (e.g., DMSO) and read the absorbance at 570 nm.
- Calculate cell viability relative to untreated controls and determine the IC50 values.

Protocol 4.2: Apoptosis Assay (Annexin V/PI Staining)

- Treat cells with PLB, PLB-NPs, or controls for 48 hours.
- Harvest the cells and wash with cold PBS.
- Resuspend cells in Annexin V binding buffer.
- Add FITC-conjugated Annexin V and Propidium Iodide (PI).
- Incubate in the dark for 15 minutes.
- Analyze the cell populations (viable, early apoptotic, late apoptotic, necrotic) using a flow cytometer.

Protocol 4.3: Western Blot Analysis

- Treat cells as described above and lyse them to extract total protein.
- Determine protein concentration using a BCA assay.
- Separate proteins by SDS-PAGE and transfer them to a PVDF membrane.
- Block the membrane and incubate with primary antibodies against key proteins (e.g., Bcl-2, Bax, cleaved Caspase-3, p-AKT, total AKT).
- Incubate with HRP-conjugated secondary antibodies.
- Visualize protein bands using an ECL detection system.

In Vivo Efficacy Assessment (General Protocol)

Animal models are used to evaluate the therapeutic efficacy and safety of PLB-NPs in a physiological system.[13][15]

Workflow for In Vivo Studies

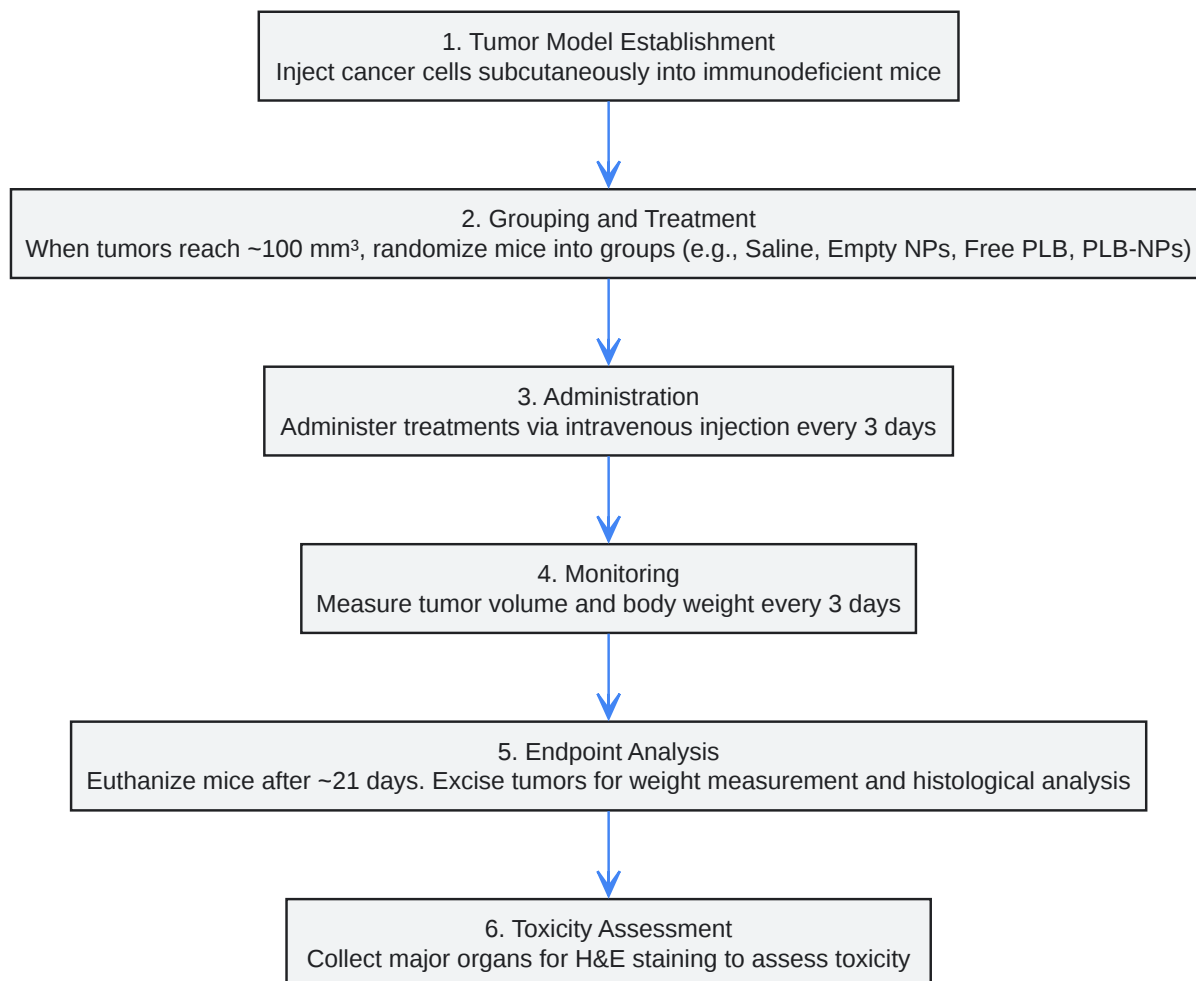

[Click to download full resolution via product page](#)

Caption: General workflow for in vivo evaluation of PLB-loaded nanoparticles.

Table 2: In Vivo Study Data Summary

Group	Average Tumor Volume (mm ³) at Day 21	Average Tumor Weight (g) at Day 21	Body Weight Change (%)
Saline Control	Data	Data	Data
Empty NPs	Data	Data	Data
Free PLB	Data	Data	Data
PLB-NPs	Data	Data	Data

Conclusion: The development of **Pseudolaroside B**-loaded nanoparticles presents a viable strategy to enhance the therapeutic potential of this potent natural anti-cancer agent. The protocols outlined here provide a framework for the successful formulation, characterization, and validation of PLB-NPs. By improving drug delivery and targeting, this nanoformulation approach could pave the way for future clinical applications in cancer therapy.

Need Custom Synthesis?

BenchChem offers custom synthesis for rare earth carbides and specific isotopic labeling.

Email: info@benchchem.com or [Request Quote Online](#).

References

- [1. Pseudolaric acid B induces apoptosis associated with the mitochondrial and PI3K/AKT/mTOR pathways in triple-negative breast cancer - PMC \[pmc.ncbi.nlm.nih.gov\]](#)
- [2. Mechanisms of pseudolaric acid B-induced apoptosis in Bel-7402 cell lines - PubMed \[pubmed.ncbi.nlm.nih.gov\]](#)
- [3. Nanoparticles for Cancer Therapy: Current Progress and Challenges - PMC \[pmc.ncbi.nlm.nih.gov\]](#)
- [4. mdpi.com \[mdpi.com\]](#)
- [5. Pseudolaric acid B induces apoptosis via activation of c-Jun N-terminal kinase and caspase-3 in HeLa cells - PubMed \[pubmed.ncbi.nlm.nih.gov\]](#)
- [6. Pseudolaric Acid B Induces Caspase-Dependent and Caspase-Independent Apoptosis in U87 Glioblastoma Cells - PMC \[pmc.ncbi.nlm.nih.gov\]](#)

- 7. Pseudolaric acid B induces apoptosis, senescence, and mitotic arrest in human breast cancer MCF-7 - PubMed [pubmed.ncbi.nlm.nih.gov]
- 8. Pseudolaric acid B triggers cell apoptosis by activating AMPK/JNK/DRP1/mitochondrial fission pathway in hepatocellular carcinoma - PubMed [pubmed.ncbi.nlm.nih.gov]
- 9. mdpi.com [mdpi.com]
- 10. Formulation and Characterization of Antigen-loaded PLGA Nanoparticles for Efficient Cross-priming of the Antigen - PMC [pmc.ncbi.nlm.nih.gov]
- 11. researchgate.net [researchgate.net]
- 12. Preparation, characterization and evaluation of targeting potential of amphotericin B-loaded engineered PLGA nanoparticles - PubMed [pubmed.ncbi.nlm.nih.gov]
- 13. Understanding the influence of experimental factors on bio-interactions of nanoparticles: Towards improving correlation between in vitro and in vivo studies - PMC [pmc.ncbi.nlm.nih.gov]
- 14. mdpi.com [mdpi.com]
- 15. In Vitro and In Vivo Methods for Analysis of Nanoparticle Potential to Induce Delayed-Type Hypersensitivity Reactions - PubMed [pubmed.ncbi.nlm.nih.gov]
- To cite this document: BenchChem. [Application Notes & Protocols: Development of Pseudolaroside B-Loaded Nanoparticles for Cancer Therapy]. BenchChem, [2026]. [Online PDF]. Available at: [<https://www.benchchem.com/product/b12372517/docs#application-notes-protocols-development-of-pseudolaroside-b-loaded-nanoparticles-for-cancer-therapy>]

Disclaimer & Data Validity:

The information provided in this document is for Research Use Only (RUO) and is strictly not intended for diagnostic or therapeutic procedures. While BenchChem strives to provide accurate protocols, we make no warranties, express or implied, regarding the fitness of this product for every specific experimental setup.

Technical Support: The protocols provided are for reference purposes. Unsure if this reagent suits your experiment?

Need Industrial/Bulk Grade? [Request Custom Synthesis Quote](#)

BenchChem

Our mission is to be the trusted global source of essential and advanced chemicals, empowering scientists and researchers to drive progress in science and industry.

Contact

Address: 3281 E Guasti Rd
Ontario, CA 91761, United States
Phone: (601) 213-4426
Email: info@benchchem.com

[Contact our Ph.D. Support Team for a compatibility check](#)