

Application Note: Enzymatic Synthesis of ¹⁵N-Labeled DNA Oligomers

Author: BenchChem Technical Support Team. **Date:** April 2026

Compound of Interest

Compound Name: *dGTP-15N5 (dilithium)*

Cat. No.: *B12372124*

[Get Quote](#)

For NMR Spectroscopy and Structural Biology Applications

Abstract & Introduction

Structural studies of DNA by multi-dimensional NMR require isotopic enrichment (

C,

N) to resolve spectral overlap and determine dynamics. While solid-phase chemical synthesis (phosphoramidite chemistry) is the industry standard for short, unlabeled oligonucleotides, it becomes prohibitively expensive and technically challenging when introducing isotopes, particularly for sequences >20 nucleotides.

Enzymatic synthesis offers a superior alternative for isotopic labeling. It utilizes DNA polymerases to incorporate

N-dNTPs onto a template.[1][2] This method is cost-effective, scalable, and produces high-molecular-weight DNA with high fidelity. This guide details the protocols for Uniform Labeling (via Primer Extension) and Site-Specific Labeling (via Gap-Filling), providing a robust workflow for producing milligram quantities of NMR-ready DNA.

Strategic Framework: Chemical vs. Enzymatic Synthesis

Before initiating synthesis, researchers must select the method that aligns with their structural goals.

Feature	Chemical Synthesis (Phosphoramidite)	Enzymatic Synthesis (Polymerase-Mediated)
Cost (Isotopes)	High: Requires N-phosphoramidites.	Low: Uses N-dNTPs (efficient incorporation).
Length Limit	< 50-60 nt (yield drops significantly).	> 100 nt (limited only by template).
Purity	Requires HPLC; failure sequences common.	High fidelity; fewer truncation products.
Labeling Type	Best for specific atom labeling.	Best for Uniform or Segment labeling.
Yield	High for small scales (<1 μmol).	Scalable to milligrams (with recycling).

Mechanism of Action

Enzymatic synthesis relies on the template-directed addition of nucleoside triphosphates (dNTPs) onto the 3'-hydroxyl group of a primer.[3]

Diagram 1: Enzymatic Synthesis Workflow

- Buffer: 10x Klenow Buffer (500 mM Tris-HCl pH 7.5, 100 mM MgCl₂, 10 mM DTT).

Step-by-Step Procedure

- Annealing:
 - Mix Template (1 equivalent) and Primer (1.2 equivalents) in 1x Buffer.
 - Heat to 95°C for 2 minutes.
 - Cool slowly to room temperature (approx. 20 mins) to ensure proper duplex formation.
- Synthesis Reaction:
 - To the annealed mixture, add N-dNTP mix (final conc. 0.2 mM each).
 - Add Klenow Fragment (exo-) (5–10 Units per nmol of template).
 - Critical Step: Incubate at 37°C for 2–4 hours.
 - Pro Tip: Add inorganic pyrophosphatase (0.01 U) to prevent pyrophosphate accumulation, which can inhibit the reaction.
- Termination & Cleavage:
 - Add EDTA (20 mM final) to stop the reaction.^[5]
 - Heat inactivate at 75°C for 20 minutes.
- Purification (Strand Separation):
 - Since the template is unlabeled and the product is labeled, they must be separated.
 - Method: Denaturing Urea-PAGE (15–20%).

- The product strand should be designed to be a different length than the template (using a "tail" on the template that isn't copied) or separated via alkaline HPLC.
- Excise the product band (UV shadowing), crush, and soak in elution buffer (0.3 M NaOAc).
- Ethanol precipitate.[5]

Protocol B: Site-Specific Labeling (Gap-Filling)

Objective: Label specific nucleotides (e.g., a specific Guanine involved in a G-quadruplex) to simplify NMR assignment.

Strategy

Use a "Gapped Duplex" approach. The template is hybridized to two flanking DNA strands, leaving a single-stranded gap at the site of interest.

Diagram 2: Gap-Filling Mechanism

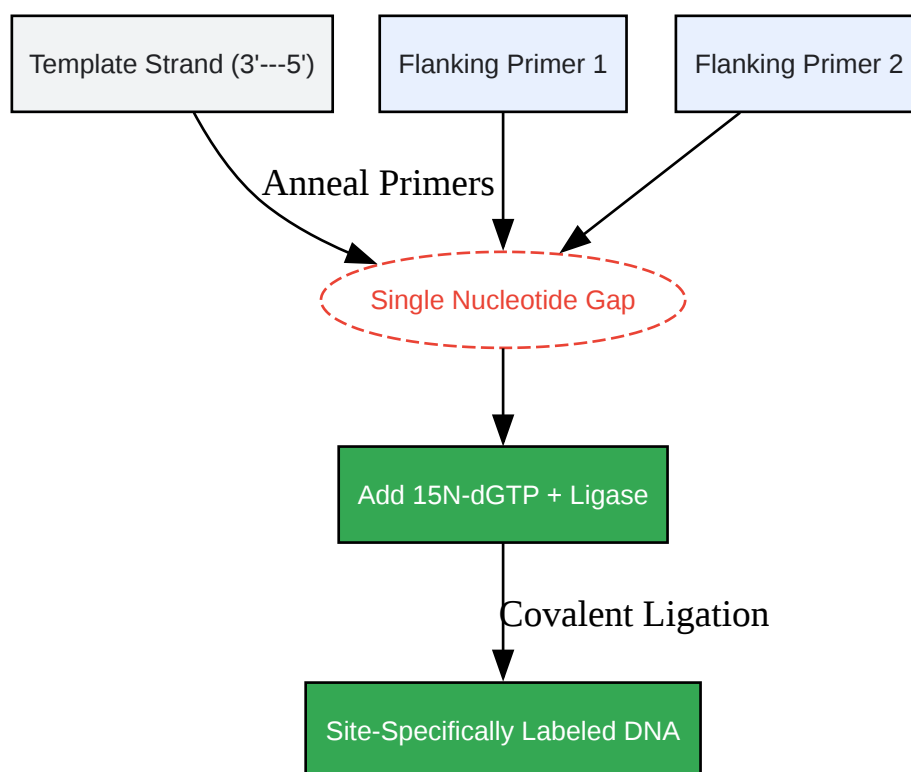

[Click to download full resolution via product page](#)

Caption: Gap-filling strategy. A specific

N-nucleotide is inserted into a defined gap, followed by ligation.

Procedure

- Annealing: Mix Template, Primer 1 (upstream), and Primer 2 (downstream) in 1:1:1 ratio. The gap should correspond to the nucleotide to be labeled.
- Incorporation:
 - Add only the specific
N-dNTP required for the gap (e.g.,
N-dGTP).
 - Add Klenow (exo-). Incubate 30 mins at 37°C.
- Ligation:
 - Add T4 DNA Ligase and ATP.
 - Incubate 1 hour at room temperature to seal the nick.
- Purification: Run on Denaturing PAGE. The ligated full-length product will run slower than the unligated primers.

QC & Validation

Every batch of

N-DNA must be validated before NMR data collection.

Method	Purpose	Acceptance Criteria
Denaturing PAGE	Check length and purity.	Single band; no n-1 or n+1 products.
ESI-MS	Verify isotope incorporation.	Mass shift corresponding to +1 Da per Nitrogen atom.
1D HSQC	Check folding and labeling.	Distinct imino proton peaks (10–14 ppm) correlating to N.

Troubleshooting Guide

Problem: Incomplete Extension (n-1 bands)

- Cause: Insufficient dNTPs or enzyme exhaustion.
- Solution: Add a "chase" step with excess unlabeled dNTPs for 15 mins at the end to force full extension (note: the 3' end will be unlabeled).

Problem: "Scrambling" of Labels

- Cause: Exonuclease activity.[\[4\]](#)[\[6\]](#)
- Solution: Ensure use of Klenow exo- or Sequenase. Avoid wild-type DNA Pol I.

Problem: Low Yield

- Cause: Template secondary structure (hairpins).
- Solution: Perform synthesis at higher temperature using Taq Polymerase (requires thermostable template design).

References

- Masse, J. E., et al. (1998). "Simple, efficient protocol for enzymatic synthesis of uniformly ¹³C, ¹⁵N-labeled DNA for heteronuclear NMR studies."[\[1\]](#) Nucleic Acids Research.[\[1\]](#)[\[2\]](#)[\[7\]](#)

- Smith, D. E., et al. (1997). "Efficient enzymatic synthesis of ^{13}C , ^{15}N -labeled DNA for NMR studies." [8] Journal of Biomolecular NMR.
- Zimmer, D. P., & Crothers, D. M. (1995). "Preparation of ^{15}N -labeled DNA for NMR studies." Methods in Enzymology.
- Thermo Fisher Scientific. "Klenow Fragment (exo-) Product Information & Protocols."

Need Custom Synthesis?

BenchChem offers custom synthesis for rare earth carbides and specific isotopic labeling.

Email: info@benchchem.com or [Request Quote Online](#).

Sources

- [1. semanticscholar.org](https://www.semanticscholar.org) [[semanticscholar.org](https://www.semanticscholar.org)]
- [2. Simple, efficient protocol for enzymatic synthesis of uniformly \$^{13}\text{C}\$, \$^{15}\text{N}\$ -labeled DNA for heteronuclear NMR studies - PubMed](#) [pubmed.ncbi.nlm.nih.gov]
- [3. researchgate.net](https://www.researchgate.net) [[researchgate.net](https://www.researchgate.net)]
- [4. nzytech.com](https://www.nzytech.com) [[nzytech.com](https://www.nzytech.com)]
- [5. promega.jp](https://www.promega.jp) [[promega.jp](https://www.promega.jp)]
- [6. documents.thermofisher.com](https://www.documents.thermofisher.com) [[documents.thermofisher.com](https://www.documents.thermofisher.com)]
- [7. Simple, efficient protocol for enzymatic synthesis of uniformly \$^{13}\text{C}\$, \$^{15}\text{N}\$ -labeled DNA for heteronuclear NMR studies - PMC](#) [[pmc.ncbi.nlm.nih.gov](https://pubmed.ncbi.nlm.nih.gov)]
- [8. Efficient enzymatic synthesis of \$^{13}\text{C}\$, \$^{15}\text{N}\$ -labeled DNA for NMR studies - PubMed](#) [pubmed.ncbi.nlm.nih.gov]
- To cite this document: BenchChem. [Application Note: Enzymatic Synthesis of ^{15}N -Labeled DNA Oligomers]. BenchChem, [2026]. [Online PDF]. Available at: [<https://www.benchchem.com/product/b12372124/docs#application-note-enzymatic-synthesis-of-15n-labeled-dna-oligomers>]

Disclaimer & Data Validity:

The information provided in this document is for Research Use Only (RUO) and is strictly not intended for diagnostic or therapeutic procedures. While BenchChem strives to provide accurate protocols, we make no warranties, express or implied, regarding the fitness of this product for every specific experimental setup.

Technical Support: The protocols provided are for reference purposes. Unsure if this reagent suits your experiment?

Need Industrial/Bulk Grade? [Request Custom Synthesis Quote](#)

BenchChem

Our mission is to be the trusted global source of essential and advanced chemicals, empowering scientists and researchers to drive progress in science and industry.

Contact

Address: 3281 E Guasti Rd
Ontario, CA 91761, United States
Phone: (601) 213-4426
Email: info@benchchem.com

[Contact our Ph.D. Support Team for a compatibility check](#)