

# Measuring ICMT Inhibition In Vitro: Application Notes and Protocols Using Icmt-IN-21

**Author:** BenchChem Technical Support Team. **Date:** April 2026

## Compound of Interest

Compound Name: *Icmt-IN-21*

Cat. No.: *B12371048*

[Get Quote](#)

## For Researchers, Scientists, and Drug Development Professionals

These application notes provide a comprehensive guide to measuring the in vitro inhibition of Isoprenylcysteine Carboxyl Methyltransferase (ICMT) using the inhibitor **Icmt-IN-21**. This document includes an overview of the ICMT signaling pathway, detailed experimental protocols for both biochemical and cell-based assays, and a summary of expected quantitative data.

## Introduction to ICMT and its Inhibition

Isoprenylcysteine Carboxyl Methyltransferase (ICMT) is a critical enzyme in the post-translational modification of a variety of cellular proteins, most notably the Ras superfamily of small GTPases.[1][2] This modification, known as carboxyl methylation, is the final step in a three-part process called prenylation.[3] This process is essential for the proper localization and function of these proteins, which are key regulators of signal transduction pathways controlling cell proliferation, differentiation, and survival.[1][2]

Inhibition of ICMT has emerged as a promising therapeutic strategy, particularly in oncology. By blocking the final step of prenylation, ICMT inhibitors can disrupt the function of oncogenic

proteins like Ras, leading to the suppression of downstream signaling pathways such as the MAPK and PI3K/Akt pathways.[1][3][4] This disruption can induce cell cycle arrest, apoptosis, and a reduction in tumor growth.[3][5] **Icmt-IN-21** is a small molecule inhibitor designed to target ICMT activity. The following protocols detail methods to quantify its inhibitory effects in vitro.

## ICMT Signaling Pathway

The following diagram illustrates the role of ICMT in the post-translational modification of Ras and its subsequent impact on downstream signaling cascades.

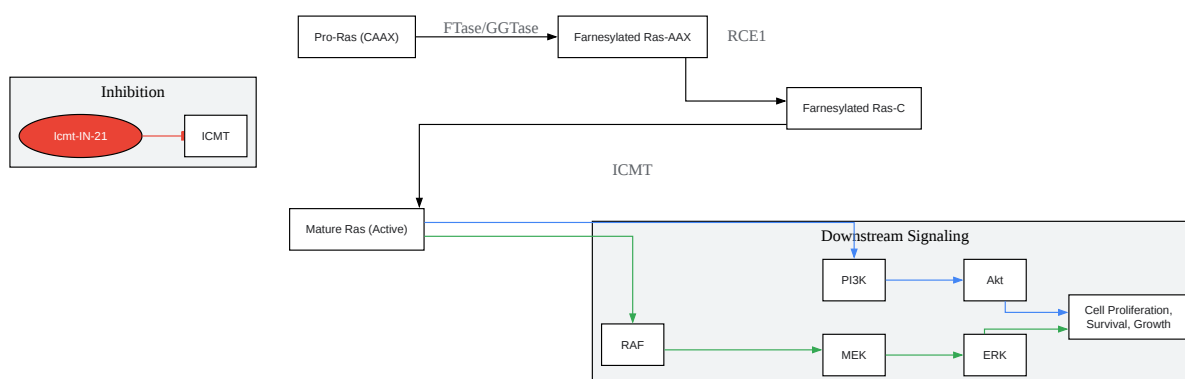

[Click to download full resolution via product page](#)

ICMT's role in Ras maturation and signaling.

## Quantitative Data Summary

The inhibitory activity of **Icmt-IN-21** can be quantified using both biochemical and cell-based assays. The following table summarizes the key quantitative parameters to be determined. Data for the well-characterized ICMT inhibitor, cysmethynil, is provided for reference.

Parameter	Icmt-IN-21 (Expected Outcome)	Cysmethynil (Reference)	Assay Type
IC50 (Enzymatic)	To be determined	12.1 $\mu$ M to 22.9 $\mu$ M[4]	Radiometric ICMT Activity Assay
IC50 (Cell Viability)	To be determined	2.9 $\mu$ M to 25 $\mu$ M (cell line dependent)[4]	MTT/CellTiter-Glo Assay
Colony Formation Inhibition	Dose-dependent reduction	Significant reduction at 10-20 $\mu$ M[5]	Soft Agar Colony Formation Assay
pERK/pAkt Reduction	Dose-dependent reduction	Observed with ICMT inhibition[1][3][6]	Western Blotting

## Experimental Protocols

The following are detailed protocols for key experiments to measure ICMT inhibition by **Icmt-IN-21**.

### Biochemical Assay: In Vitro Radiometric ICMT Activity Assay

This assay directly measures the enzymatic activity of ICMT by quantifying the transfer of a radiolabeled methyl group from S-adenosyl-L-[methyl-<sup>3</sup>H]methionine ([<sup>3</sup>H]SAM) to a prenylated substrate.

Experimental Workflow:

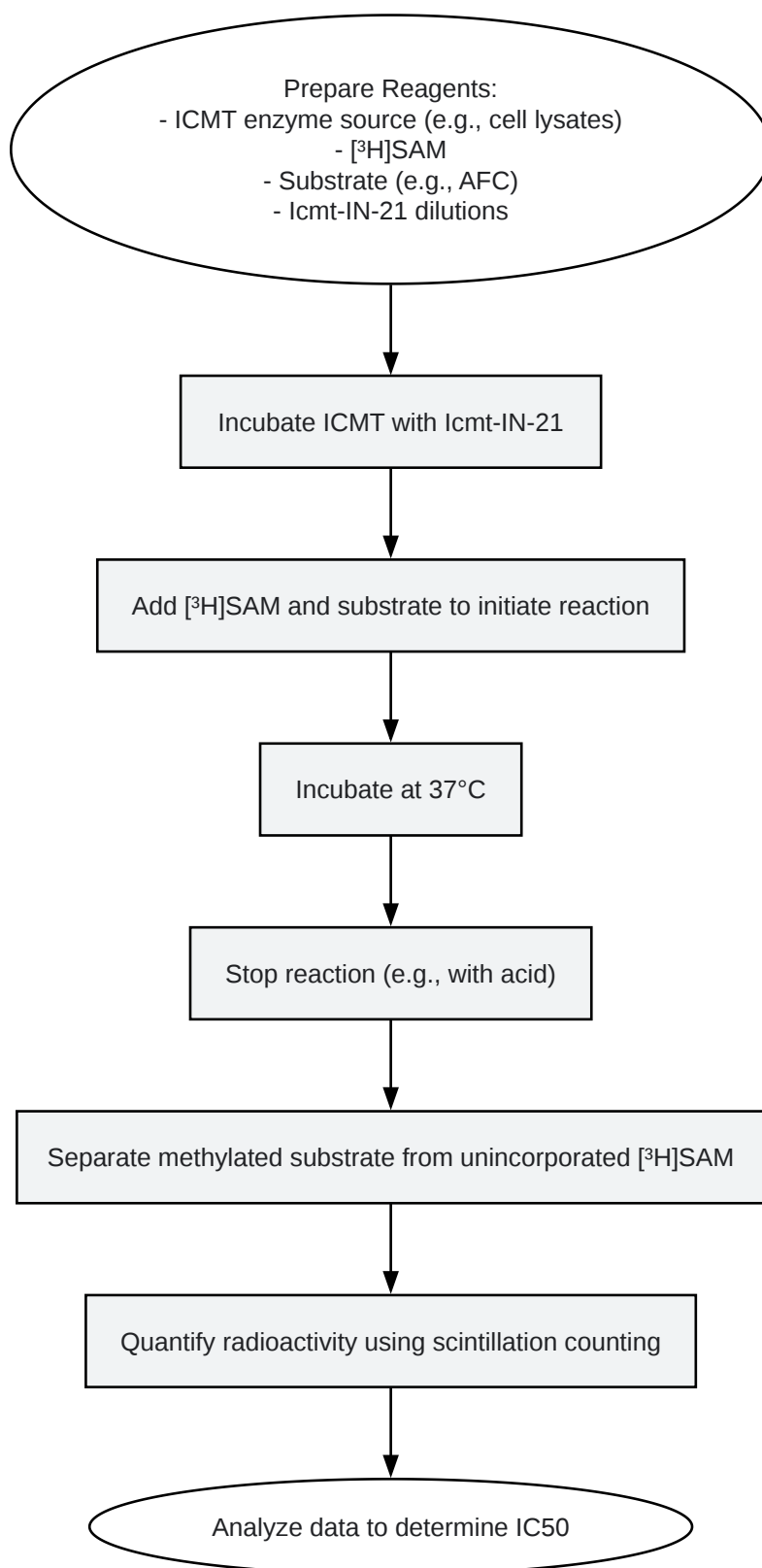

[Click to download full resolution via product page](#)

Workflow for the radiometric ICMT assay.

## Materials:

- ICMT Enzyme Source: Microsomal fractions from cells overexpressing ICMT or cell lysates.
- Substrate: N-acetyl-S-farnesyl-L-cysteine (AFC) or a biotinylated version for easier separation.
- Methyl Donor: S-adenosyl-L-[methyl-<sup>3</sup>H]methionine ([<sup>3</sup>H]SAM).
- Inhibitor: **lcmt-IN-21** dissolved in DMSO.
- Assay Buffer: 100 mM HEPES (pH 7.4), 5 mM MgCl<sub>2</sub>.
- Stop Solution: 6% Trichloroacetic acid (TCA).
- Scintillation fluid and vials.
- Microplate scintillation counter.

## Protocol:

- Prepare **lcmt-IN-21** Dilutions: Prepare a serial dilution of **lcmt-IN-21** in DMSO. Further dilute in assay buffer to the desired final concentrations. Include a DMSO-only control.
- Enzyme and Inhibitor Pre-incubation: In a microplate, add the ICMT enzyme source to each well. Add the diluted **lcmt-IN-21** or DMSO control and pre-incubate for 15-30 minutes at room temperature.
- Reaction Initiation: Prepare a reaction mix containing the substrate (e.g., 4 μM AFC) and [<sup>3</sup>H]SAM (e.g., 5 μM) in assay buffer. Add this mix to each well to start the reaction.
- Incubation: Incubate the plate at 37°C for 20-60 minutes.
- Reaction Termination: Stop the reaction by adding cold 6% TCA.
- Separation and Quantification:

- If using a non-biotinylated substrate, the reaction mixture can be spotted onto filter paper, washed to remove unincorporated [<sup>3</sup>H]SAM, and the radioactivity on the filter quantified by scintillation counting.
- If using a biotinylated substrate, the methylated substrate can be captured on streptavidin-coated beads or plates, washed, and the radioactivity quantified.[7]
- Data Analysis: Plot the percentage of ICMT inhibition against the log concentration of **lcmt-IN-21**. Fit the data to a dose-response curve to determine the IC<sub>50</sub> value.

## Cell-Based Assay: Cell Viability (MTT) Assay

This assay assesses the effect of ICMT inhibition on the metabolic activity and proliferation of cancer cells.

Protocol:

- Cell Seeding: Plate cancer cells (e.g., pancreatic or breast cancer cell lines known to be sensitive to ICMT inhibition) in a 96-well plate at a density of 1,000-5,000 cells per well and allow them to adhere overnight.
- Treatment: Treat the cells with a serial dilution of **lcmt-IN-21**. Include a DMSO-only control.
- Incubation: Incubate the cells for 48-72 hours.
- MTT Addition: Add MTT solution to each well and incubate for 2-4 hours at 37°C, allowing viable cells to form formazan crystals.
- Solubilization: Add a solubilization solution (e.g., DMSO or a specialized reagent) to dissolve the formazan crystals.
- Absorbance Measurement: Measure the absorbance at a wavelength of 570 nm using a microplate reader.
- Data Analysis: Normalize the absorbance values to the DMSO control to determine the percentage of cell viability. Plot the percentage of viability against the log concentration of **lcmt-IN-21** and calculate the IC<sub>50</sub>.

## Cell-Based Assay: Western Blotting for Downstream Signaling

This method is used to confirm that **lcmt-IN-21** inhibits the downstream signaling pathways regulated by ICMT substrates like Ras.

Protocol:

- Cell Treatment: Plate cells and treat with various concentrations of **lcmt-IN-21** for a specified time (e.g., 24 hours).
- Cell Lysis: Lyse the cells in RIPA buffer containing protease and phosphatase inhibitors.
- Protein Quantification: Determine the protein concentration of each lysate using a BCA or Bradford assay.
- SDS-PAGE and Transfer: Separate equal amounts of protein by SDS-PAGE and transfer to a PVDF membrane.
- Immunoblotting:
  - Block the membrane with 5% non-fat milk or BSA in TBST.
  - Incubate with primary antibodies against phosphorylated and total forms of key signaling proteins (e.g., p-ERK, total ERK, p-Akt, total Akt).
  - Wash and incubate with HRP-conjugated secondary antibodies.
- Detection: Visualize the protein bands using an enhanced chemiluminescence (ECL) substrate and an imaging system.
- Analysis: Quantify the band intensities and normalize the levels of phosphorylated proteins to the total protein levels to assess the extent of signaling inhibition.[\[6\]](#)

## Conclusion

The protocols outlined in these application notes provide a robust framework for the in vitro characterization of the ICMT inhibitor **lcmt-IN-21**. By employing a combination of biochemical

and cell-based assays, researchers can effectively determine the potency and mechanism of action of this compound, facilitating its further development as a potential therapeutic agent.

### Need Custom Synthesis?

BenchChem offers custom synthesis for rare earth carbides and specific isotopic labeling.

Email: [info@benchchem.com](mailto:info@benchchem.com) or [Request Quote Online](#).

## References

- [1. Isoprenylcysteine Carboxyl Methyltransferase Activity Modulates Endothelial Cell Apoptosis - PMC \[pmc.ncbi.nlm.nih.gov\]](#)
- [2. Isoprenylcysteine carboxylmethyltransferase is required for the impact of mutant KRAS on TAZ protein level and cancer cell self-renewal - PubMed \[pubmed.ncbi.nlm.nih.gov\]](#)
- [3. Suppression of isoprenylcysteine carboxylmethyltransferase compromises DNA damage repair | Life Science Alliance \[life-science-alliance.org\]](#)
- [4. Isoprenyl carboxyl methyltransferase inhibitors: a brief review including recent patents - PMC \[pmc.ncbi.nlm.nih.gov\]](#)
- [5. aacrjournals.org \[aacrjournals.org\]](#)
- [6. Suppression of isoprenylcysteine carboxylmethyltransferase compromises DNA damage repair - PMC \[pmc.ncbi.nlm.nih.gov\]](#)
- [7. pnas.org \[pnas.org\]](#)
- To cite this document: BenchChem. [Measuring ICMT Inhibition In Vitro: Application Notes and Protocols Using Icmt-IN-21]. BenchChem, [2026]. [Online PDF]. Available at: [\[https://www.benchchem.com/product/b12371048/docs#measuring-icmt-inhibition-in-vitro-application-notes-and-protocols-using-icmt-in-21\]](https://www.benchchem.com/product/b12371048/docs#measuring-icmt-inhibition-in-vitro-application-notes-and-protocols-using-icmt-in-21)

---

### Disclaimer & Data Validity:

The information provided in this document is for Research Use Only (RUO) and is strictly not intended for diagnostic or therapeutic procedures. While BenchChem strives to provide accurate protocols, we make no warranties, express or implied, regarding the fitness of this product for every specific experimental setup.

**Technical Support:** The protocols provided are for reference purposes. Unsure if this reagent suits your experiment?

**Need Industrial/Bulk Grade?** [Request Custom Synthesis Quote](#)

## BenchChem

Our mission is to be the trusted global source of essential and advanced chemicals, empowering scientists and researchers to drive progress in science and industry.

### Contact

Address: 3281 E Guasti Rd  
Ontario, CA 91761, United States  
Phone: (601) 213-4426  
Email: [info@benchchem.com](mailto:info@benchchem.com)

[Contact our Ph.D. Support Team for a compatibility check](#)