

# An In-depth Technical Guide to Endogenous Ligands for GPR120/FFAR4

**Author:** BenchChem Technical Support Team. **Date:** April 2026

## Compound of Interest

Compound Name: *GPR120 Agonist 4*

Cat. No.: *B12371319*

[Get Quote](#)

For Researchers, Scientists, and Drug Development Professionals

This guide provides a comprehensive overview of the endogenous ligands for the G-protein coupled receptor 120 (GPR120), also known as Free Fatty Acid Receptor 4 (FFAR4). It details their signaling mechanisms, presents quantitative data on their activity, and provides detailed protocols for key experimental assays used in their characterization.

## Endogenous Ligands of GPR120/FFAR4

GPR120/FFAR4 is a receptor for medium to long-chain free fatty acids (FFAs), playing a crucial role in metabolism and inflammation. The primary endogenous ligands are long-chain fatty acids (LCFAs), including both saturated and unsaturated fatty acids.

Key Endogenous Ligands:

- Omega-3 Polyunsaturated Fatty Acids (PUFAs): These are considered the most potent endogenous agonists for GPR120/FFAR4. Key examples include:
  - Docosahexaenoic acid (DHA)

- Eicosapentaenoic acid (EPA)
- Alpha-linolenic acid (ALA)[1]
- Omega-6 Polyunsaturated Fatty Acids (PUFAs):
  - Linoleic acid (LA)[2][3]
- Saturated Fatty Acids (SFAs): Long-chain saturated fatty acids (C14-C18) can also activate GPR120/FFAR4.[1]
- Monounsaturated Fatty Acids (MUFAs): Unsaturated fatty acids with a carbon chain length of C16-C22 are also recognized by the receptor.[1]

These fatty acids bind to GPR120/FFAR4 to initiate a cascade of intracellular signaling events that mediate the receptor's physiological effects.

## Quantitative Data for Endogenous Ligands

The potency of endogenous ligands for GPR120/FFAR4 can be quantified using various in vitro assays. The half-maximal effective concentration (EC50) is a common measure of a ligand's potency in functional assays, while the inhibition constant (Ki) is determined in binding assays.

Endogenous Ligand	Assay Type	Species	Cell Line	Potency (EC50/pEC50/Ki)	Reference
Linoleic acid	Calcium Mobilization	Human	HEK293	pEC50 = 5.16	[2]
$\alpha$ -Linolenic acid	$\beta$ -arrestin Recruitment	Human	CHO-K1	EC50 ~10 $\mu$ M	[4]
Docosahexaenoic acid	Calcium Mobilization	Human	HEK293	EC50 ~10-100 $\mu$ M	[2]
Eicosapentaenoic acid	Calcium Mobilization	Human	HEK293	EC50 ~10-100 $\mu$ M	
9(R)-PAHSA	Radioligand Binding ( $[^3\text{H}]$ -TUG-891)	-	GPR120-expressing cells	Ki value can be determined	[5]

## Signaling Pathways of GPR120/FFAR4

Activation of GPR120/FFAR4 by its endogenous ligands initiates two primary signaling cascades: a Gq/11-mediated pathway responsible for metabolic effects, and a  $\beta$ -arrestin-2-mediated pathway that drives the receptor's potent anti-inflammatory actions.

### Gq/11-Mediated Metabolic Signaling Pathway

This pathway is crucial for the metabolic regulation exerted by GPR120/FFAR4, including the secretion of incretin hormones like glucagon-like peptide-1 (GLP-1) and the regulation of adipogenesis.[4]

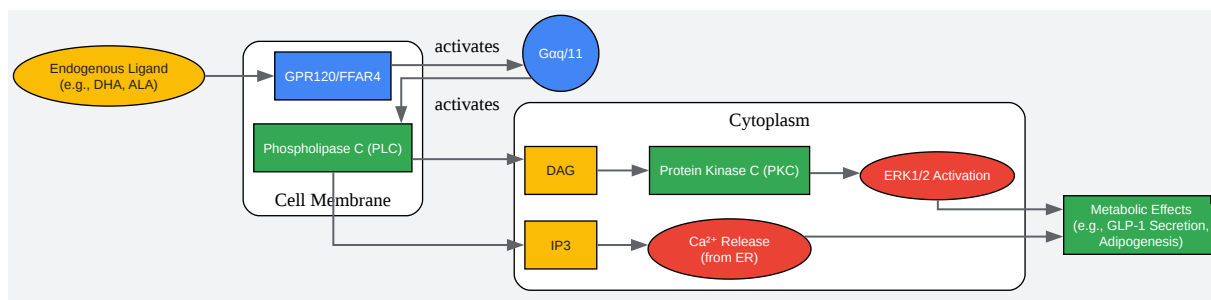

[Click to download full resolution via product page](#)

Caption: Gq/11-Mediated Signaling Pathway of GPR120/FFAR4.

## β-arrestin-2-Mediated Anti-Inflammatory Signaling Pathway

This pathway is central to the anti-inflammatory effects of GPR120/FFAR4. Ligand binding leads to the recruitment of β-arrestin-2, which in turn inhibits key pro-inflammatory signaling cascades.

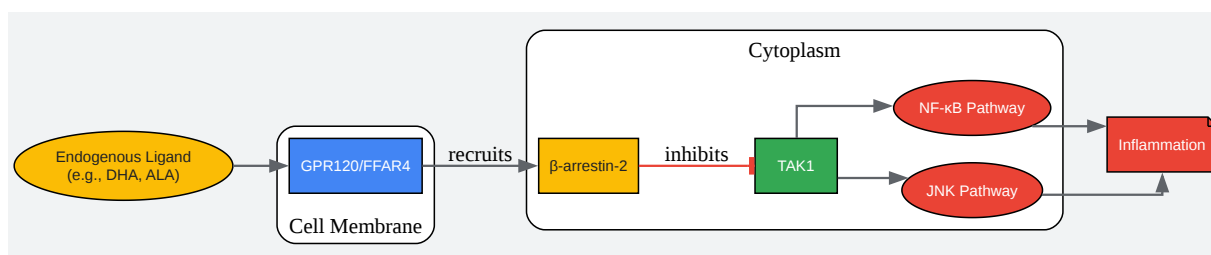

[Click to download full resolution via product page](#)

Caption: β-arrestin-2-Mediated Anti-Inflammatory Signaling.

## Experimental Protocols

The characterization of endogenous ligands for GPR120/FFAR4 relies on a variety of in vitro assays. Below are detailed protocols for key experiments.

### Calcium Mobilization Assay (FLIPR)

This assay measures the increase in intracellular calcium concentration following GPR120/FFAR4 activation via the Gq/11 pathway.

Workflow Diagram:



[Click to download full resolution via product page](#)

Caption: Workflow for a Calcium Mobilization Assay using FLIPR.

Detailed Protocol:

- Cell Culture:
  - HEK293 cells stably expressing human GPR120/FFAR4 are seeded into 96-well black-walled, clear-bottom plates at a density of 50,000 cells/well.
  - Cells are cultured overnight at 37°C in a 5% CO<sub>2</sub> incubator.
- Dye Loading:
  - The growth medium is removed, and cells are washed with Hanks' Balanced Salt Solution (HBSS).
  - Cells are then incubated with a Fluo-4 NW dye loading solution (Molecular Devices) for 1 hour at 37°C according to the manufacturer's instructions.[6]

- Measurement:
  - The plate is placed in a FLIPR (Fluorometric Imaging Plate Reader) instrument.
  - A baseline fluorescence reading is taken before the addition of the ligand.
  - Endogenous ligands, serially diluted in HBSS, are added to the wells.
  - Fluorescence is monitored in real-time for approximately 2-5 minutes to capture the calcium flux.[1]
- Data Analysis:
  - The change in fluorescence is plotted against the ligand concentration.
  - EC50 values are determined by fitting the data to a sigmoidal dose-response curve using appropriate software (e.g., GraphPad Prism).

## $\beta$ -arrestin Recruitment Assay (BRET)

This assay measures the recruitment of  $\beta$ -arrestin-2 to the activated GPR120/FFAR4, a key step in the anti-inflammatory signaling pathway.

Workflow Diagram:



[Click to download full resolution via product page](#)

Caption: Workflow for a  $\beta$ -arrestin Recruitment BRET Assay.

Detailed Protocol:

- Cell Culture and Transfection:

- HEK293 cells are co-transfected with plasmids encoding GPR120/FFAR4 fused to Renilla luciferase (Rluc8) and  $\beta$ -arrestin-2 fused to a yellow fluorescent protein variant (e.g., Venus).[7]
- Transfected cells are seeded into white, clear-bottom 96-well plates.
- Assay Procedure:
  - Cells are washed with a suitable assay buffer.
  - Endogenous ligands are added at various concentrations.
  - The luciferase substrate, Coelenterazine h, is added to each well.
  - The plate is incubated for 5-10 minutes at room temperature.[7]
- Measurement:
  - Luminescence is measured simultaneously at two wavelengths using a plate reader capable of BRET measurements (e.g., emission filters for Rluc8 at ~485 nm and Venus at ~530 nm).[8]
- Data Analysis:
  - The BRET ratio is calculated as the ratio of the light emitted by the acceptor (Venus) to the light emitted by the donor (Rluc8).
  - The net BRET ratio is determined by subtracting the basal BRET ratio (no ligand) from the ligand-induced BRET ratio.
  - EC50 values are calculated from dose-response curves.

## ERK1/2 Phosphorylation Assay (Western Blot)

This assay detects the phosphorylation of Extracellular signal-Regulated Kinases 1 and 2 (ERK1/2), a downstream event in the Gq/11 signaling pathway.

Workflow Diagram:

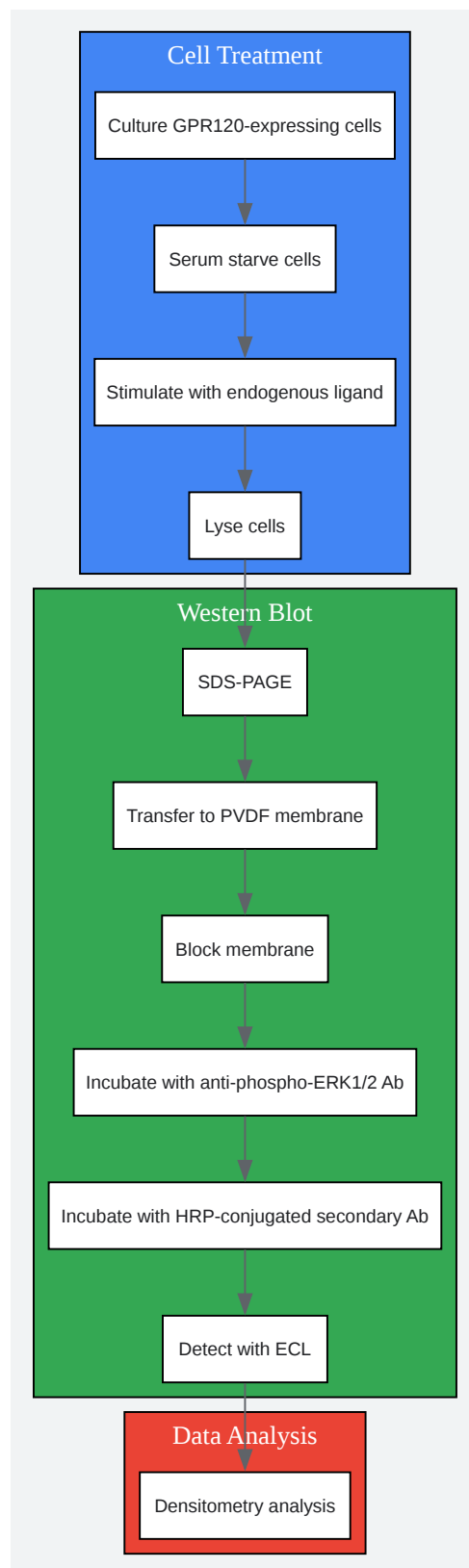

[Click to download full resolution via product page](#)

Caption: Workflow for ERK1/2 Phosphorylation Western Blot Assay.

#### Detailed Protocol:

- Cell Treatment:
  - GPR120/FFAR4-expressing cells are grown to confluence and then serum-starved for 4-12 hours to reduce basal ERK1/2 phosphorylation.[\[9\]](#)
  - Cells are stimulated with the endogenous ligand at various concentrations for a specific time (e.g., 5-15 minutes).
  - The reaction is stopped by placing the cells on ice and adding lysis buffer.[\[9\]](#)
- Western Blotting:
  - Cell lysates are resolved by SDS-PAGE and transferred to a PVDF membrane.
  - The membrane is blocked with 5% BSA in TBST for 1 hour.[\[10\]](#)
  - The membrane is incubated overnight at 4°C with a primary antibody specific for phosphorylated ERK1/2.[\[10\]](#)
  - After washing, the membrane is incubated with an HRP-conjugated secondary antibody.
  - The signal is detected using an enhanced chemiluminescence (ECL) substrate.[\[10\]](#)
- Data Analysis:
  - The membrane is stripped and re-probed with an antibody for total ERK1/2 to normalize for protein loading.
  - Band intensities are quantified using densitometry software.
  - The ratio of phosphorylated ERK1/2 to total ERK1/2 is calculated to determine the extent of activation.

## Conclusion

The identification and characterization of endogenous ligands for GPR120/FFAR4 are crucial for understanding the receptor's role in health and disease. The methodologies described in this guide provide a framework for researchers to investigate the pharmacology of this important therapeutic target. The dual signaling capabilities of GPR120/FFAR4, mediating both metabolic and anti-inflammatory effects, make it an attractive target for the development of novel therapeutics for metabolic disorders and inflammatory diseases.

### Need Custom Synthesis?

BenchChem offers custom synthesis for rare earth carbides and specific isotopic labeling.

Email: [info@benchchem.com](mailto:info@benchchem.com) or [Request Quote Online](#).

## References

- 1. Characterization of G Protein-coupled Receptors by a Fluorescence-based Calcium Mobilization Assay - PMC [[pmc.ncbi.nlm.nih.gov](https://pubmed.ncbi.nlm.nih.gov/)]
- 2. GPR120/FFAR4 Pharmacology: Focus on Agonists in Type 2 Diabetes Mellitus Drug Discovery - PMC [[pmc.ncbi.nlm.nih.gov](https://pubmed.ncbi.nlm.nih.gov/)]
- 3. [pubs.acs.org](https://pubs.acs.org) [[pubs.acs.org](https://pubs.acs.org)]
- 4. Characterizing pharmacological ligands to study the long-chain fatty acid receptors GPR40/FFA1 and GPR120/FFA4 - PMC [[pmc.ncbi.nlm.nih.gov](https://pubmed.ncbi.nlm.nih.gov/)]
- 5. [benchchem.com](https://www.benchchem.com) [[benchchem.com](https://www.benchchem.com)]
- 6. A Multiplexed Fluorescent Calcium and NFAT Reporter Gene Assay to Identify GPCR Agonists - PMC [[pmc.ncbi.nlm.nih.gov](https://pubmed.ncbi.nlm.nih.gov/)]
- 7. In-cell arrestin-receptor interaction assays - PMC [[pmc.ncbi.nlm.nih.gov](https://pubmed.ncbi.nlm.nih.gov/)]
- 8. [researchgate.net](https://www.researchgate.net) [[researchgate.net](https://www.researchgate.net)]
- 9. Measuring agonist-induced ERK MAP kinase phosphorylation for G-protein-coupled receptors - PMC [[pmc.ncbi.nlm.nih.gov](https://pubmed.ncbi.nlm.nih.gov/)]
- 10. [benchchem.com](https://www.benchchem.com) [[benchchem.com](https://www.benchchem.com)]
- To cite this document: BenchChem. [An In-depth Technical Guide to Endogenous Ligands for GPR120/FFAR4]. BenchChem, [2026]. [Online PDF]. Available at: [<https://www.benchchem.com/product/b12371319/docs#an-in-depth-technical-guide-to-endogenous-ligands-for-gpr120-ffar4>]

**Disclaimer & Data Validity:**

The information provided in this document is for Research Use Only (RUO) and is strictly not intended for diagnostic or therapeutic procedures. While BenchChem strives to provide accurate protocols, we make no warranties, express or implied, regarding the fitness of this product for every specific experimental setup.

**Technical Support:** The protocols provided are for reference purposes. Unsure if this reagent suits your experiment?

**Need Industrial/Bulk Grade?** [Request Custom Synthesis Quote](#)

## BenchChem

Our mission is to be the trusted global source of essential and advanced chemicals, empowering scientists and researchers to drive progress in science and industry.

### Contact

Address: 3281 E Guasti Rd  
Ontario, CA 91761, United States  
Phone: (601) 213-4426  
Email: [info@benchchem.com](mailto:info@benchchem.com)

[Contact our Ph.D. Support Team for a compatibility check](#)