

Application Notes: TAMRA-PEG3-NH2 Protein Labeling

Author: BenchChem Technical Support Team. **Date:** April 2026

Compound of Interest

Compound Name: Tamra-peg3-NH2

Cat. No.: B12370807

[Get Quote](#)

For Researchers, Scientists, and Drug Development Professionals

Introduction

Fluorescent labeling of proteins is a cornerstone technique for elucidating biological function, enabling researchers to visualize, track, and quantify proteins in a multitude of experimental settings. Tetramethylrhodamine (TAMRA) is a robust and widely used rhodamine-derived fluorophore, recognized for its bright orange-red fluorescence and photostability.[1][2] This document provides a detailed protocol for labeling proteins using **TAMRA-PEG3-NH2**, a specialized probe designed for covalent attachment to carboxyl groups on a target protein.

The **TAMRA-PEG3-NH2** molecule features three key components:

- TAMRA Fluorophore: Provides a strong fluorescence signal with excitation and emission maxima around 555 nm and 580 nm, respectively.[1]
- PEG3 Spacer: A three-unit polyethylene glycol linker that enhances the hydrophilicity of the dye, reduces the potential for aggregation, and minimizes steric hindrance between the dye and the protein, preserving biological activity.[3]

- Amine (NH₂) Group: A terminal primary amine that serves as the reactive site for conjugation.

This reagent facilitates the labeling of a protein's carboxylic acid residues (aspartic acid, glutamic acid, and the C-terminus) through a two-step reaction mediated by a carbodiimide, such as 1-Ethyl-3-(3-dimethylaminopropyl)carbodiimide (EDC), and N-hydroxysuccinimide (NHS) or its water-soluble analog, Sulfo-NHS.[4] The resulting TAMRA-labeled proteins are valuable tools for a wide range of applications, including fluorescence microscopy, live-cell imaging, flow cytometry, and Fluorescence Resonance Energy Transfer (FRET)-based assays.

Principle of Reaction

The conjugation of **TAMRA-PEG3-NH₂** to a protein's carboxyl groups is achieved via a two-step carbodiimide-mediated reaction. This approach offers greater control and efficiency compared to a single-step reaction.

- Activation Step: EDC reacts with the protein's carboxyl groups to form a highly reactive but unstable O-acylisourea intermediate. The addition of Sulfo-NHS displaces the O-acylisourea group to form a more stable, amine-reactive Sulfo-NHS ester. This activation step is most efficient in a slightly acidic environment (pH 4.7-6.0) and in buffers free of extraneous amines and carboxylates.
- Conjugation Step: The primary amine of the **TAMRA-PEG3-NH₂** molecule nucleophilically attacks the semi-stable Sulfo-NHS ester, resulting in the formation of a stable amide bond and the release of the Sulfo-NHS leaving group. This reaction is most efficient at a physiological to slightly alkaline pH (7.2-8.0).

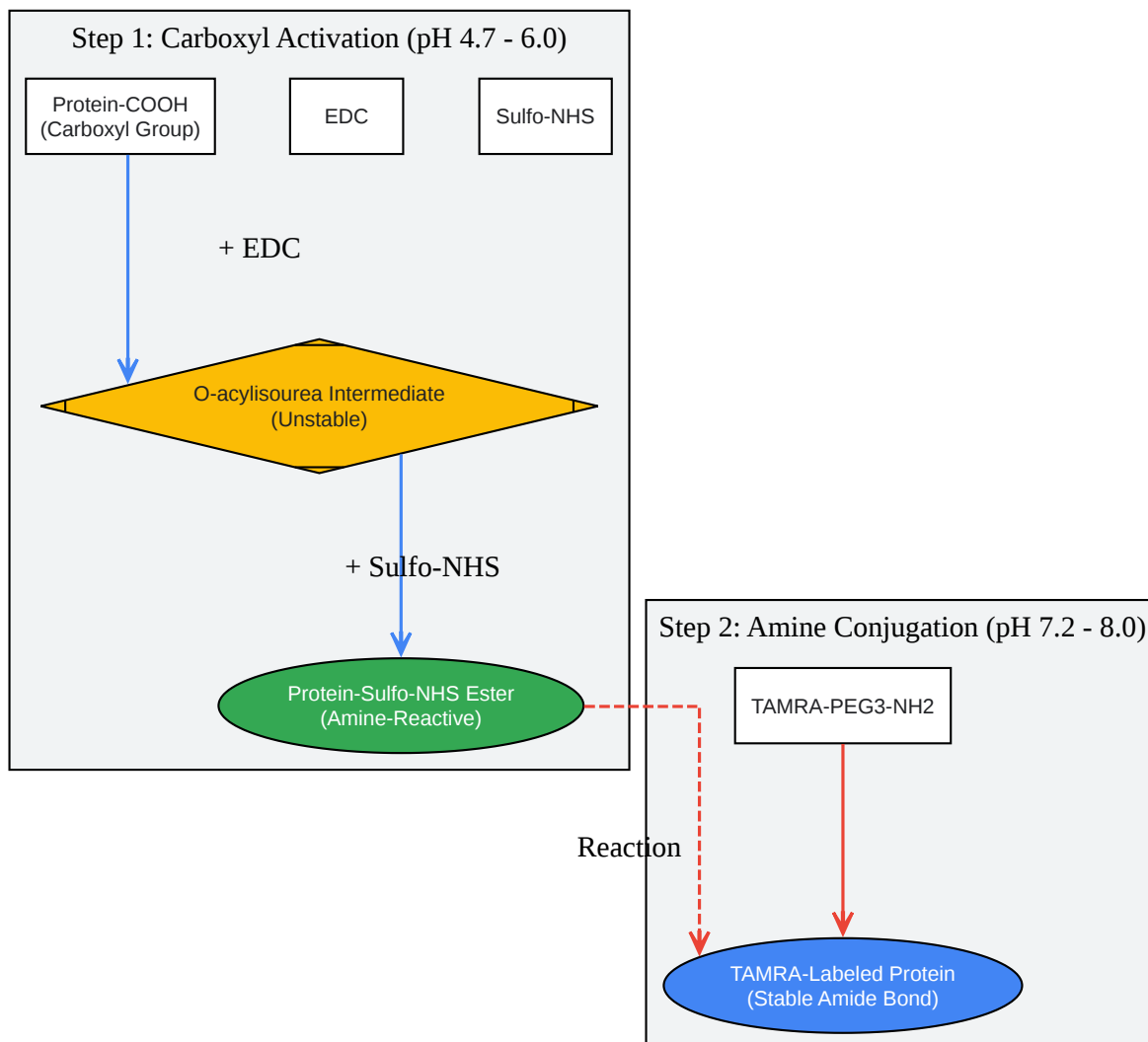

[Click to download full resolution via product page](#)

Caption: Chemical principle of two-step EDC/Sulfo-NHS protein labeling.

Quantitative Data Summary

Successful protein labeling requires an understanding of the fluorophore's properties and a method to quantify the extent of labeling.

Table 1: Spectroscopic Properties of TAMRA.

Property	Value	Reference
Excitation Maximum (λ_{ex})	~555 nm	
Emission Maximum (λ_{em})	~580 nm	
Molar Extinction Coefficient (ϵ)	~90,000 M ⁻¹ cm ⁻¹	

| Recommended Quencher | Dabcyl | |

Table 2: Example Data for Labeling Efficiency. This table provides representative data for cell surface protein labeling, which can be adapted for in-solution protein characterization using fluorescence spectroscopy.

Dye Concentration (μ M)	Incubation Time (min)	Mean Fluorescence Intensity (A.U.)
1	30	1500 \pm 120
5	30	4500 \pm 350
10	30	8200 \pm 600

Data adapted from a cell-based labeling protocol and is for illustrative purposes.

Table 3: Calculation of Degree of Labeling (DOL). The DOL, or the average number of dye molecules per protein molecule, can be estimated using absorbance spectroscopy.

Step	Description	Formula
1	Measure the absorbance of the conjugate at 280 nm (A_{280}) and at the dye's max absorbance, ~555 nm (A_{max}).	-
2	Calculate the protein concentration. A correction factor (CF) is used to account for the dye's absorbance at 280 nm. For TAMRA, this is approximately 0.36.	Protein Conc. (M) = $[A_{280} - (A_{max} * CF)] / \epsilon_{protein}$
3	Calculate the dye concentration using the Beer-Lambert law.	Dye Conc. (M) = A_{max} / ϵ_{dye}
4	Calculate the DOL.	DOL = Dye Conc. (M) / Protein Conc. (M)

Note: For more accurate protein concentration, a BCA or Bradford protein assay is recommended as an alternative to A_{280} measurements.

Experimental Protocols

This protocol details the procedure for labeling a protein with **TAMRA-PEG3-NH2**. It is essential to optimize the molar ratios of EDC, Sulfo-NHS, and dye to the protein to achieve the desired DOL without causing protein precipitation or loss of function.

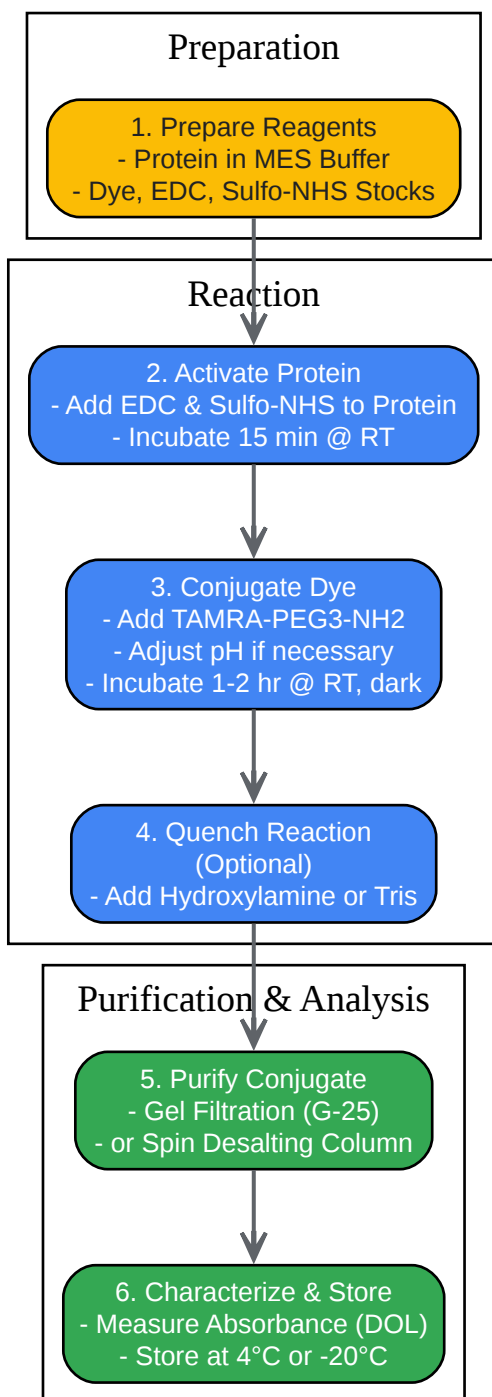

[Click to download full resolution via product page](#)

Caption: General experimental workflow for protein labeling.

Materials and Reagents

- Protein of Interest: Purified and at a known concentration (typically 1-10 mg/mL).

- **TAMRA-PEG3-NH2**: Amine-functionalized dye.
- EDC (1-Ethyl-3-(3-dimethylaminopropyl)carbodiimide HCl).
- Sulfo-NHS (N-hydroxysulfosuccinimide).
- Activation Buffer: 2-(N-morpholino)ethanesulfonic acid (MES) buffer, 0.1 M, pH 4.7-6.0.
- Reaction Buffer: Phosphate-buffered saline (PBS), pH 7.2-7.5. Do not use buffers containing primary amines (e.g., Tris).
- Quenching Buffer (Optional): 1 M Tris-HCl, pH 8.0; or 1 M Hydroxylamine, pH 8.5.
- Solvent: Anhydrous Dimethylsulfoxide (DMSO) or Dimethylformamide (DMF).
- Purification: Desalting column (e.g., Sephadex G-25) or spin columns.

Protocol Steps

Step 1: Reagent Preparation

- Protein Solution: Prepare the protein in ice-cold Activation Buffer (e.g., 0.1 M MES, pH 6.0). Ensure the buffer does not contain any primary amines or carboxylates.
- **TAMRA-PEG3-NH2** Stock: Prepare a 10 mg/mL stock solution in anhydrous DMSO. This should be prepared fresh.
- EDC Stock: Prepare a 10 mg/mL solution in Activation Buffer immediately before use. EDC is moisture-sensitive and hydrolyzes in water.
- Sulfo-NHS Stock: Prepare a 10 mg/mL solution in Activation Buffer immediately before use.

Step 2: Activation of Protein Carboxyl Groups

- Determine the required amounts of EDC and Sulfo-NHS. A 10- to 50-fold molar excess of EDC and Sulfo-NHS over the protein is a good starting point.
- Add the calculated volume of EDC stock solution to the protein solution. Mix gently.

- Immediately add the calculated volume of Sulfo-NHS stock solution. Mix gently.
- Incubate the reaction for 15 minutes at room temperature.

Step 3: Conjugation with **TAMRA-PEG3-NH2**

- Add the **TAMRA-PEG3-NH2** stock solution to the activated protein. A 10- to 20-fold molar excess of dye over protein is recommended, but this should be optimized.
- For optimal conjugation, the pH should be raised to 7.2-7.5. This can be achieved by adding a small amount of 1 M PBS (pH 7.5) or by performing a rapid buffer exchange.
- Incubate the reaction for 1-2 hours at room temperature, protected from light. Gentle stirring or rocking is recommended.

Step 4: Quenching the Reaction (Optional)

- To stop the labeling reaction, add Quenching Buffer to a final concentration of 20-50 mM (e.g., add 50 μ L of 1 M Tris per 1 mL of reaction).
- Incubate for 15-30 minutes at room temperature. This step hydrolyzes any unreacted Sulfo-NHS esters and consumes unreacted dye if it is an NHS-ester form (not applicable here, but good practice).

Step 5: Purification of Labeled Protein

- Separate the TAMRA-labeled protein from unreacted dye and reaction byproducts.
- Gel Filtration: Apply the reaction mixture to a desalting column (e.g., Sephadex G-25) pre-equilibrated with your desired storage buffer (e.g., PBS). The labeled protein will elute in the void volume, while smaller molecules like free dye will be retained longer.
- Spin Columns: For smaller sample volumes, spin desalting columns offer a rapid and efficient method for purification. Follow the manufacturer's protocol.

Step 6: Characterization and Storage

- Measure the absorbance of the purified conjugate at 280 nm and ~555 nm to determine the protein concentration and calculate the Degree of Labeling (see Table 3).
- Store the purified conjugate at 4°C for short-term use, protected from light. For long-term storage, add a cryoprotectant like glycerol (to 50%) and store in aliquots at -20°C or -80°C.

Application Example: Probing a Signaling Pathway

A TAMRA-labeled protein, such as a growth factor or an antibody, can be used as a probe to study cellular signaling pathways. For instance, a TAMRA-labeled ligand can be incubated with live cells to visualize its binding to a specific cell surface receptor. Subsequent downstream events, such as receptor internalization or the activation of intracellular signaling cascades, can then be monitored using fluorescence microscopy.

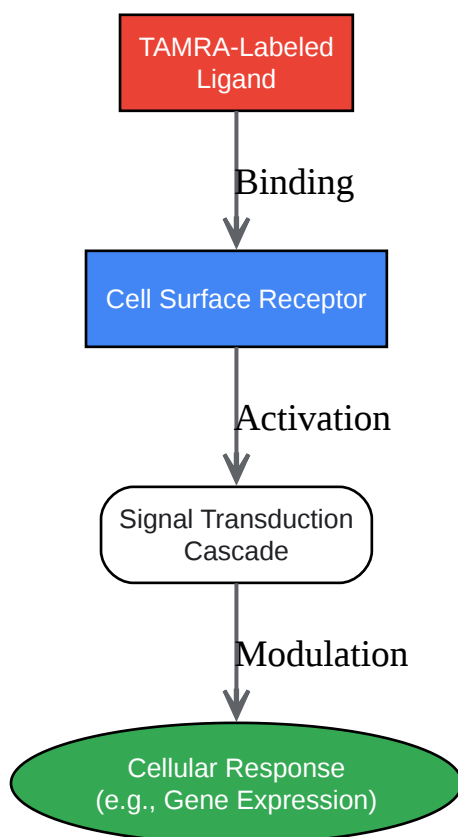

[Click to download full resolution via product page](#)

Caption: Using a TAMRA-labeled ligand to track a signaling pathway.

Troubleshooting

Problem	Possible Cause	Suggested Solution
Low Labeling Efficiency (Low DOL)	<ul style="list-style-type: none"> - Inactive EDC/Sulfo-NHS due to hydrolysis. - Insufficient molar excess of reagents. - Incorrect buffer pH during activation or conjugation. - Protein has few accessible carboxyl groups. 	<ul style="list-style-type: none"> - Prepare EDC and Sulfo-NHS solutions fresh immediately before use. - Increase the molar ratio of EDC, Sulfo-NHS, and/or dye. - Verify buffer pH is 4.7-6.0 for activation and 7.2-8.0 for conjugation. - Consider an alternative labeling strategy (e.g., labeling primary amines with a TAMRA-NHS ester).
Protein Precipitation	<ul style="list-style-type: none"> - High DOL can increase hydrophobicity. - Protein is unstable at the reaction pH. - High concentration of organic solvent (DMSO). 	<ul style="list-style-type: none"> - Reduce the molar ratio of dye to protein. - Perform a pilot experiment to test protein stability at different pH values. - Ensure the final concentration of DMSO is low (typically <10% v/v).
High Background Fluorescence	<ul style="list-style-type: none"> - Incomplete removal of free dye. 	<ul style="list-style-type: none"> - Repeat the purification step or use a column with a longer bed height for better separation.
Loss of Protein Activity	<ul style="list-style-type: none"> - Labeling occurred at a critical residue in the active site. - Protein denaturation during the labeling process. 	<ul style="list-style-type: none"> - Reduce the DOL to favor labeling of more accessible, less critical residues. - Perform the reaction at 4°C, although this will increase the required incubation time.

Need Custom Synthesis?

BenchChem offers custom synthesis for rare earth carbides and specific isotopic labeling.

Email: info@benchchem.com or [Request Quote Online](#).

References

- [1. lifetein.com \[lifetein.com\]](https://lifetein.com)
- [2. TAMRA dye for labeling in life science research \[baseclick.eu\]](https://baseclick.eu)
- [3. benchchem.com \[benchchem.com\]](https://benchchem.com)
- [4. cdn.gbiosciences.com \[cdn.gbiosciences.com\]](https://cdn.gbiosciences.com)
- To cite this document: BenchChem. [Application Notes: TAMRA-PEG3-NH2 Protein Labeling]. BenchChem, [2026]. [Online PDF]. Available at: [\[https://www.benchchem.com/product/b12370807/docs#application-notes-tamra-peg3-nh2-protein-labeling\]](https://www.benchchem.com/product/b12370807/docs#application-notes-tamra-peg3-nh2-protein-labeling)

Disclaimer & Data Validity:

The information provided in this document is for Research Use Only (RUO) and is strictly not intended for diagnostic or therapeutic procedures. While BenchChem strives to provide accurate protocols, we make no warranties, express or implied, regarding the fitness of this product for every specific experimental setup.

Technical Support: The protocols provided are for reference purposes. Unsure if this reagent suits your experiment?

Need Industrial/Bulk Grade? [Request Custom Synthesis Quote](#)

BenchChem

Our mission is to be the trusted global source of essential and advanced chemicals, empowering scientists and researchers to drive progress in science and industry.

Contact

Address: 3281 E Guasti Rd
Ontario, CA 91761, United States
Phone: (601) 213-4426
Email: info@benchchem.com

Contact our Ph.D. Support Team for a compatibility check