

A Comparative Kinome Profile Analysis of Tibremciclib and Other CDK4/6 Inhibitors

Author: BenchChem Technical Support Team. **Date:** December 2025

Compound of Interest

Compound Name: Tibremciclib

Cat. No.: B12370543

[Get Quote](#)

For Researchers, Scientists, and Drug Development Professionals

This guide provides a detailed comparison of the kinome profiles of the novel cyclin-dependent kinase 4/6 (CDK4/6) inhibitor, **Tibremciclib** (BPI-16350), against the established CDK4/6 inhibitors: Palbociclib, Ribociclib, and Abemaciclib. This analysis is based on publicly available preclinical and clinical data, offering insights into their selectivity and potential off-target effects.

Introduction to CDK4/6 Inhibition

Cyclin-dependent kinases 4 and 6 are key regulators of the cell cycle, promoting the transition from the G1 to the S phase.[1] In many cancers, the CDK4/6 pathway is hyperactivated, leading to uncontrolled cell proliferation.[2] CDK4/6 inhibitors, such as Palbociclib, Ribociclib, and Abemaciclib, have demonstrated significant efficacy in the treatment of hormone receptor-positive (HR+), human epidermal growth factor receptor 2-negative (HER2-) advanced or metastatic breast cancer.[3][4] **Tibremciclib** is a novel, potent, and selective CDK4/6 inhibitor currently under investigation.[5][6] Understanding the broader kinome profile of these inhibitors is crucial for predicting their full spectrum of activity, potential side effects, and mechanisms of resistance.

Comparative Kinome Profiling Data

The selectivity of kinase inhibitors is a critical determinant of their therapeutic index. The following tables summarize the available quantitative data on the inhibitory activity of Palbociclib, Ribociclib, and Abemaciclib against a panel of kinases. While comprehensive,

directly comparable kinome-wide data for **Tibremciclib** is not yet publicly available, descriptive information on its selectivity is provided.

Table 1: IC50/Ki Values (nM) of CDK4/6 Inhibitors Against Primary Targets and Select Off-Targets

Kinase Target	Palbociclib (IC50/Ki, nM)	Ribociclib (IC50/Ki, nM)	Abemaciclib (IC50/Ki, nM)	Tibremciclib (BPI-16350) (IC50/Ki, nM)
CDK4/cyclin D1	11	10	2	Potent, specific data not available
CDK6/cyclin D3	15	39	10	Potent, specific data not available
CDK1/cyclin B	>10,000	>10,000	65	Less inhibition than Abemaciclib
CDK2/cyclin A	>10,000	>10,000	16	Data not available
CDK9/cyclin T1	>10,000	>10,000	4	Less inhibition than Abemaciclib
GSK3 β	Not a primary target	Not a primary target	7.9	Data not available
CAMK2A	Not a primary target	Not a primary target	Potent inhibitor	Data not available

Data compiled

from various

sources.[\[7\]](#)[\[8\]](#)

Note that assay

conditions can

vary between

studies, affecting

absolute values.

Tibremciclib (BPI-16350) Kinome Profile Overview:

Preclinical studies have described **Tibremciclib** as a highly potent and selective CDK4/6 inhibitor.[5][6] Its kinome profile shows that its binding is significantly concentrated on the CGMC group of kinases, which includes CDKs, MAPKs, GSKs, and CLKs.[6] Notably, **Tibremciclib** demonstrates less inhibitory activity against CDK9 compared to Abemaciclib, suggesting a potentially different off-target profile.[6] Further quantitative data from comprehensive kinome-wide screens are needed for a direct comparison with other CDK4/6 inhibitors.

Signaling Pathway Overview

The primary mechanism of action for CDK4/6 inhibitors is the disruption of the Cyclin D-CDK4/6-Rb pathway, leading to G1 cell cycle arrest. The following diagram illustrates the core components of this pathway and the points of intervention by these inhibitors.

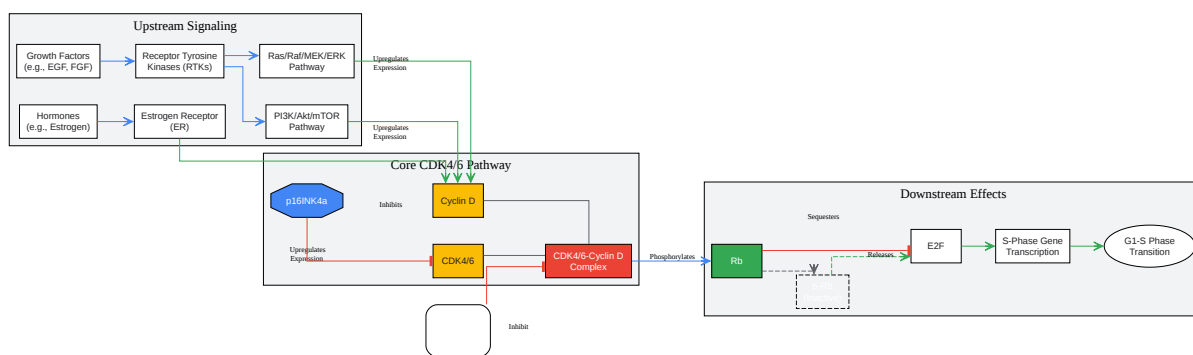

[Click to download full resolution via product page](#)

Caption: CDK4/6 Signaling Pathway and Inhibition.

Experimental Protocols for Kinome Profiling

Kinome profiling is essential for determining the selectivity of kinase inhibitors. Two common high-throughput methods are KINOMEScan® and Multiplexed Inhibitor Bead Mass Spectrometry (MIB/MS).

KINOMEScan® Assay

The KINOMEScan® platform is a competition-based binding assay that quantitatively measures the interaction between a test compound and a large panel of kinases.

Methodology Overview:

- **Assay Components:** The assay utilizes three main components: a DNA-tagged kinase, an immobilized ligand that binds to the active site of the kinase, and the test compound.[5]
- **Competitive Binding:** The test compound is incubated with the DNA-tagged kinase and the immobilized ligand. If the test compound binds to the kinase's active site, it will compete with the immobilized ligand, reducing the amount of kinase captured on the solid support.[5]
- **Quantification:** The amount of kinase bound to the immobilized ligand is measured using quantitative PCR (qPCR) to detect the DNA tag. A lower qPCR signal indicates stronger binding of the test compound to the kinase.[5]
- **Data Analysis:** Results are typically reported as "percent of control," where a lower percentage signifies greater inhibition. For more detailed analysis, dissociation constants (Kd) can be determined by running the assay with a range of compound concentrations.[9]

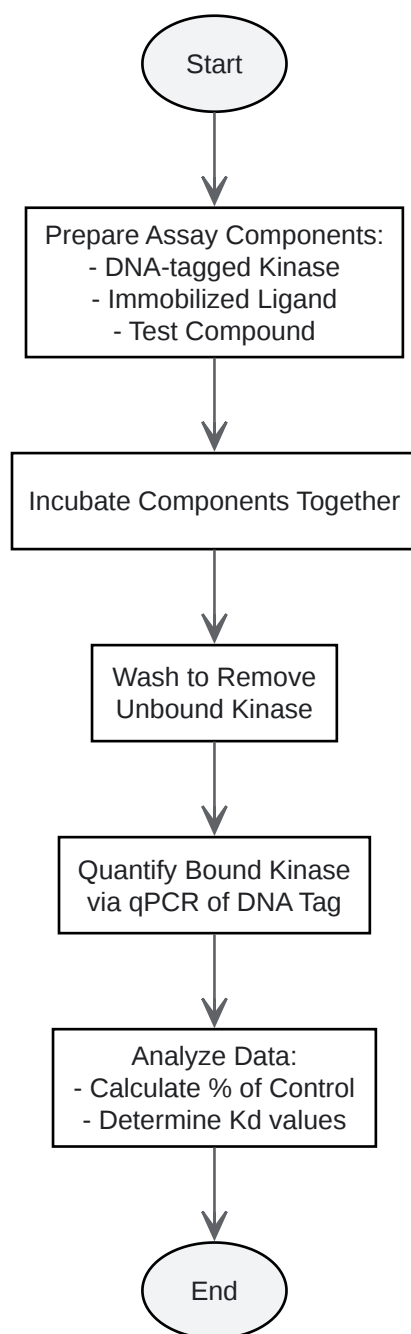

[Click to download full resolution via product page](#)

Caption: KINOMEscan® Experimental Workflow.

Multiplexed Inhibitor Bead Mass Spectrometry (MIB/MS)

MIB/MS is a chemical proteomics approach that uses a mixture of kinase inhibitors immobilized on beads to capture a broad range of kinases from cell or tissue lysates.

Methodology Overview:

- **Lysate Preparation:** Cells or tissues are lysed to release proteins, including kinases.
- **MIB Affinity Chromatography:** The lysate is passed through a column containing multiplexed inhibitor beads. Kinases in the lysate bind to the immobilized inhibitors.[\[10\]](#)
- **Washing and Elution:** The column is washed to remove non-specifically bound proteins. The captured kinases are then eluted.
- **Protein Digestion and Mass Spectrometry:** The eluted kinases are digested into peptides, which are then analyzed by liquid chromatography-tandem mass spectrometry (LC-MS/MS) to identify and quantify the captured kinases.[\[10\]](#)
- **Competitive Profiling:** To determine the targets of a specific inhibitor, lysates can be pre-incubated with the soluble inhibitor before the MIB pulldown. Kinases that are bound by the soluble inhibitor will not be captured by the MIBs, leading to a reduced signal in the MS analysis.[\[10\]](#)

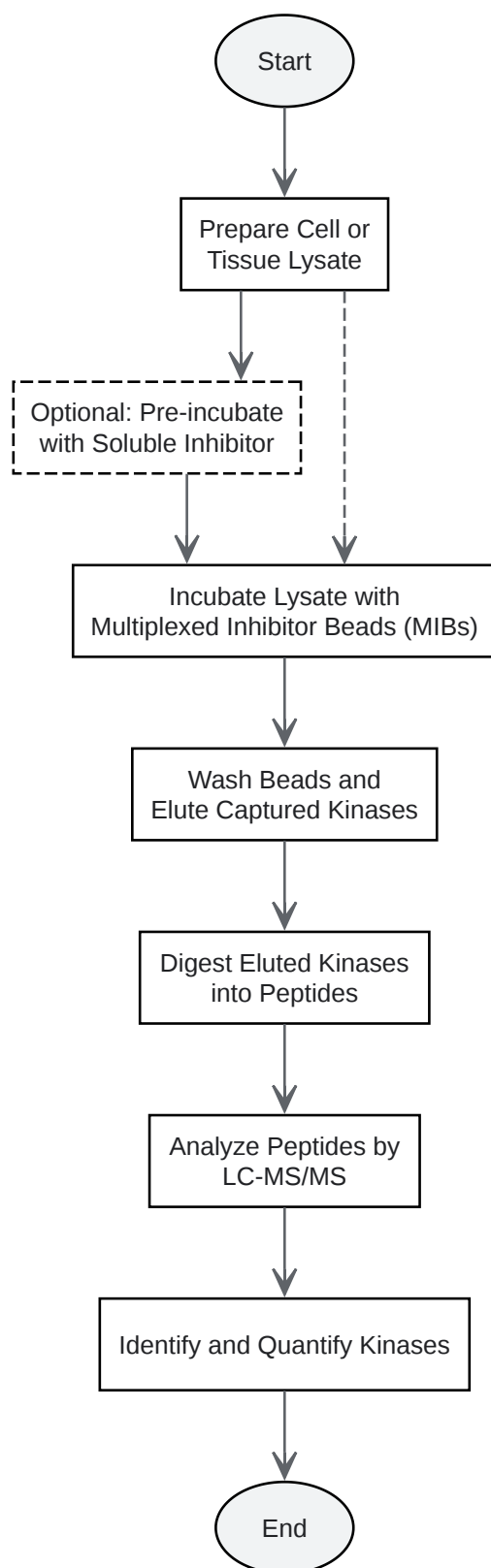

[Click to download full resolution via product page](#)

Caption: MIB/MS Experimental Workflow.

Conclusion

The established CDK4/6 inhibitors Palbociclib, Ribociclib, and Abemaciclib exhibit distinct kinome profiles. Palbociclib and Ribociclib are highly selective for CDK4/6, whereas Abemaciclib demonstrates a broader spectrum of activity, inhibiting other kinases such as CDK1, CDK2, and GSK3 β .^{[4][7]} This polypharmacology may contribute to its different efficacy and toxicity profile.^[4]

Tibremciclib is a promising novel CDK4/6 inhibitor with high potency and selectivity.^{[5][6]} Preclinical data suggests a favorable profile with potentially fewer off-target effects on kinases like CDK9 compared to Abemaciclib.^[6] However, a comprehensive, publicly available kinome-wide dataset is required for a definitive comparative analysis. As more data on **Tibremciclib** becomes available, a clearer understanding of its place within the therapeutic landscape of CDK4/6 inhibitors will emerge. The methodologies of KINOMEScan[®] and MIB/MS will be instrumental in further elucidating its precise molecular interactions.

Need Custom Synthesis?

BenchChem offers custom synthesis for rare earth carbides and specific isotopic labeling.

Email: info@benchchem.com or [Request Quote Online](#).

References

- 1. aacrjournals.org [aacrjournals.org]
- 2. researchgate.net [researchgate.net]
- 3. A phase I dose-escalation and dose-expansion study of tibremciclib, a novel CDK4/6 inhibitor, monotherapy and in combination with fulvestrant in HR-positive/HER2-negative advanced breast cancer - PMC [pmc.ncbi.nlm.nih.gov]
- 4. Abemaciclib, Palbociclib, and Ribociclib in Real-World Data: A Direct Comparison of First-Line Treatment for Endocrine-Receptor-Positive Metastatic Breast Cancer - PMC [pmc.ncbi.nlm.nih.gov]
- 5. CDK4/6 inhibition in cancer: beyond cell cycle arrest - PMC [pmc.ncbi.nlm.nih.gov]
- 6. researchgate.net [researchgate.net]

- 7. Multiomics profiling establishes the polypharmacology of FDA approved CDK4/6 inhibitors and the potential for differential clinical activity. | CCSP [ccsp.hms.harvard.edu]
- 8. Pre-clinical Selectivity Profile of the CDK4/6 Inhibitor Ribociclib Compared With That of Palbociclib and Abemaciclib - OAK Open Access Archive [oak.novartis.com]
- 9. chayon.co.kr [chayon.co.kr]
- 10. Application of Integrated Drug Screening/Kinome Analysis to Identify Inhibitors of Gemcitabine-Resistant Pancreatic Cancer Cell Growth - PMC [pmc.ncbi.nlm.nih.gov]
- To cite this document: BenchChem. [A Comparative Kinome Profile Analysis of Tibremciclib and Other CDK4/6 Inhibitors]. BenchChem, [2025]. [Online PDF]. Available at: [https://www.benchchem.com/product/b12370543#kinome-profiling-of-tibremciclib-versus-other-cdk4-6-inhibitors]

Disclaimer & Data Validity:

The information provided in this document is for Research Use Only (RUO) and is strictly not intended for diagnostic or therapeutic procedures. While BenchChem strives to provide accurate protocols, we make no warranties, express or implied, regarding the fitness of this product for every specific experimental setup.

Technical Support: The protocols provided are for reference purposes. Unsure if this reagent suits your experiment? [[Contact our Ph.D. Support Team for a compatibility check](#)]

Need Industrial/Bulk Grade? [Request Custom Synthesis Quote](#)

BenchChem

Our mission is to be the trusted global source of essential and advanced chemicals, empowering scientists and researchers to drive progress in science and industry.

Contact

Address: 3281 E Guasti Rd
Ontario, CA 91761, United States
Phone: (601) 213-4426
Email: info@benchchem.com