

Application Note: Characterization of Tryptophan Radical g-Tensors using EPR Spectroscopy

Author: BenchChem Technical Support Team. **Date:** April 2026

Compound of Interest

Compound Name: *Tryptophan radical*

Cat. No.: *B1237849*

[Get Quote](#)

Audience: Researchers, scientists, and drug development professionals.

Abstract: **Tryptophan radicals** are crucial intermediates in a variety of biological electron transfer and catalytic reactions. Electron Paramagnetic Resonance (EPR) spectroscopy is a powerful technique for characterizing these transient species. The g-tensor, a fundamental magnetic parameter, is highly sensitive to the electronic structure and local environment of the radical. This application note provides a detailed overview and protocols for using EPR spectroscopy, particularly high-frequency EPR, to precisely determine the g-tensors of **tryptophan radicals**. Resolving the principal values of the g-tensor allows for the differentiation between neutral and cationic radicals, the identification of radical sites in proteins, and the characterization of environmental factors such as hydrogen bonding.

Introduction to Tryptophan Radicals and EPR

Tryptophan residues can be oxidized to form radical species that participate in enzymatic catalysis and long-range electron transfer pathways within proteins.[1] The electronic structure of these radicals is described by magnetic parameters, including the g-tensor and hyperfine couplings. The g-tensor reflects the interaction of the unpaired electron's spin with the external

magnetic field and is influenced by spin-orbit coupling. Consequently, its anisotropy (the difference between its principal values) provides a sensitive probe of the radical's identity (neutral vs. cationic) and its interaction with the surrounding environment.[2][3]

Conventional X-band (~9.5 GHz) EPR spectra of **tryptophan radicals** often suffer from poor resolution due to the small g-anisotropy, where the spectral features overlap with the much larger hyperfine couplings.[4] High-frequency/high-field EPR (HF-EPR), operating at frequencies from ~95 GHz (W-band) to 700 GHz and beyond, enhances the g-tensor resolution, making the separation of the principal g-values possible.[2][4] This increased resolution is essential for accurately determining the g-tensor and extracting detailed information about the radical's structure and function.[4][5]

Data Presentation: Tryptophan Radical g-Tensors

The following table summarizes experimentally determined g-tensor values for various **tryptophan radicals** from the literature, showcasing the differences between cationic and neutral species and the influence of the local environment.

Radical Species	Matrix / Protein Environment	g_x / g_{\min}	g_y / g_{mid}	g_z / g_{\max}	EPR Frequency (GHz)	Reference
Cationic Radicals						
L-Tryptophan	Frozen Solution (Photocatalyst)	2.00227	2.00240	2.00329	406.4	[1]
D-Tryptophan	Frozen Solution (Photocatalyst)	2.00228	2.00238	2.00328	406.4	[1]
5-OH-Tryptophan	Frozen Solution (Photocatalyst)	2.00224	2.00277	2.00350	406.4	[1]
5-F-Tryptophan	Frozen Solution (Photocatalyst)	2.00226	2.00240	2.00336	406.4	[1]
7-OH-Tryptophan	Frozen Solution (Photocatalyst)	2.00231	2.00235	2.00305	406.4	[1]
Neutral Radicals						
Trp48 (AzC Azurin)	Protein (Hydrophobic Core)	2.00361	2.00270	2.00215	~690	[2]

Trp108 (ReAzS Azurin)	Protein (Solvent- Exposed, H-Bonded)	2.00346	2.00264	2.00216	~690	[2]
Trp Radical (Wa•)	E. coli RNR (Y122F mutant)	2.0033	2.0024	2.0021	9.4	[6][7]
Trp Radical	B. adusta Versatile Peroxidase	2.0033	2.0024	2.0021	9.4 & 94	[8]
Trp Radical	P. eryngii Versatile Peroxidase	2.0033	2.0024	2.0021	9.4 & 94	[8]

Experimental Protocols

Detailed methodologies for generating and characterizing **tryptophan radicals** are presented below.

This protocol is adapted from a method for generating **tryptophan radicals** for HFEPR studies at cryogenic temperatures.[1]

A. Reagents and Equipment

- L-Tryptophan (or derivative)
- [Ru(bpy)₃]Cl₂ (photocatalyst)
- Sodium persulfate (sacrificial oxidant)
- Phosphate buffer (pH 7.0)
- EPR sample cups (e.g., 150 µL volume)
- Liquid nitrogen

- 405 nm violet laser (e.g., 120 mW)
- X-band and High-Frequency EPR spectrometers

B. Procedure

- Prepare a stock solution of the tryptophan derivative in phosphate buffer.
- Prepare stock solutions of $[\text{Ru}(\text{bpy})_3]\text{Cl}_2$ and sodium persulfate in the same buffer.
- In an EPR sample cup, mix the solutions to final concentrations of approximately 10 mM tryptophan, 1 mM $[\text{Ru}(\text{bpy})_3]\text{Cl}_2$, and 20 mM sodium persulfate.
- Immediately freeze the sample by plunging it into liquid nitrogen (77 K).
- Irradiate the frozen sample at 77 K for 30 minutes using a 405 nm laser to generate the radical species.[\[1\]](#)
- Verify radical formation using a preliminary scan on an X-band EPR spectrometer.
- Transfer the sample to the HF-EPR spectrometer for data acquisition.

C. HF-EPR Data Acquisition

- Cool the spectrometer to the desired temperature (e.g., 4.5 K).[\[1\]](#)
- Acquire spectra at the desired high frequency (e.g., 406.4 GHz) with appropriate modulation amplitude (e.g., 0.3 mT).[\[1\]](#)
- Use a magnetic field standard (e.g., atomic hydrogen) for precise g-value calibration.[\[1\]](#)
- Simulate the experimental spectrum using software that allows for fitting the principal values of the g-tensor to obtain an accurate determination.[\[1\]](#)

This protocol, adapted from studies on solution-phase radicals, is suitable for generating radical cations for X-band EPR.[\[9\]](#)

A. Reagents and Equipment

- L-Tryptophan
- Cerium(IV) sulfate (Ce^{4+} , oxidant)
- Sulfuric acid (H_2SO_4)
- Deionized water
- Fast-flow continuous-wave EPR system with a flat cell
- Syringe pump or peristaltic pump system

B. Procedure

- Prepare two separate aqueous solutions:
 - Solution A: 1.0 mM L-Tryptophan in 0.45 M H_2SO_4 .
 - Solution B: 0.5 mM Ce^{4+} in 0.45 M H_2SO_4 .
- Set up the fast-flow system to mix equal volumes of Solution A and Solution B milliseconds before they enter the EPR flat cell.
- Maintain a constant total flow rate (e.g., 60 mL/min) to ensure a steady-state concentration of the radical in the EPR cavity.[9]
- Record the EPR spectrum at room temperature. Typical X-band spectrometer settings might include 20 mW microwave power and 0.1 mT modulation amplitude.[9]

C. Data Analysis

- The resulting isotropic spectrum will be characterized by hyperfine coupling constants.
- While the full g-tensor cannot be resolved, the isotropic g-value can be determined. Computer simulation of the spectrum is required to extract the hyperfine coupling constants, which confirm the identity of the radical cation.[9]

Visualizations: Workflows and Mechanisms

Diagrams created using the DOT language illustrate key experimental and logical flows.

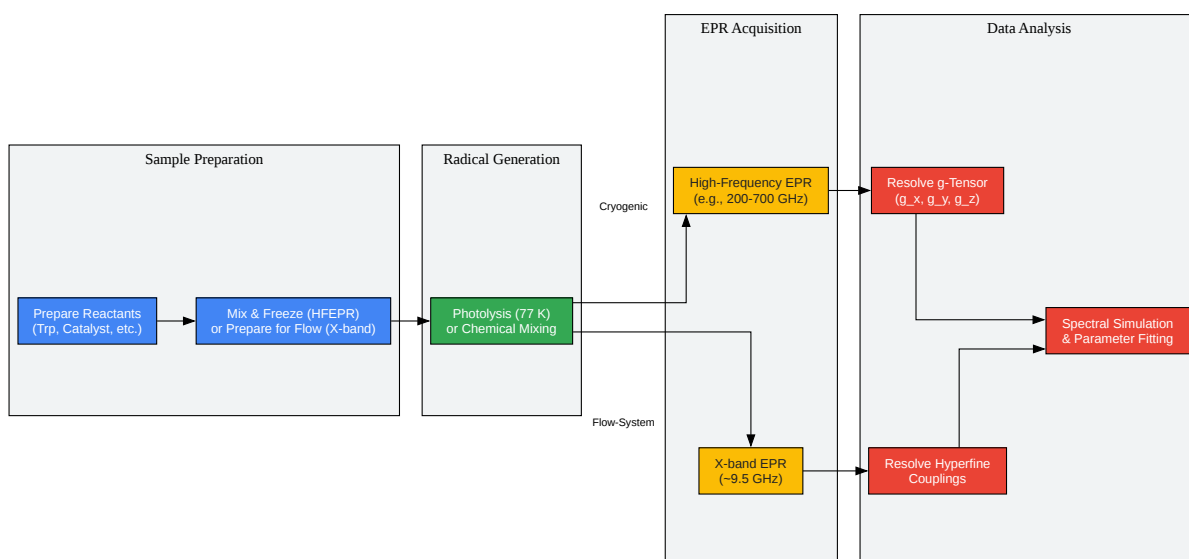

[Click to download full resolution via product page](#)

Caption: Experimental workflow for **tryptophan radical** characterization by EPR.

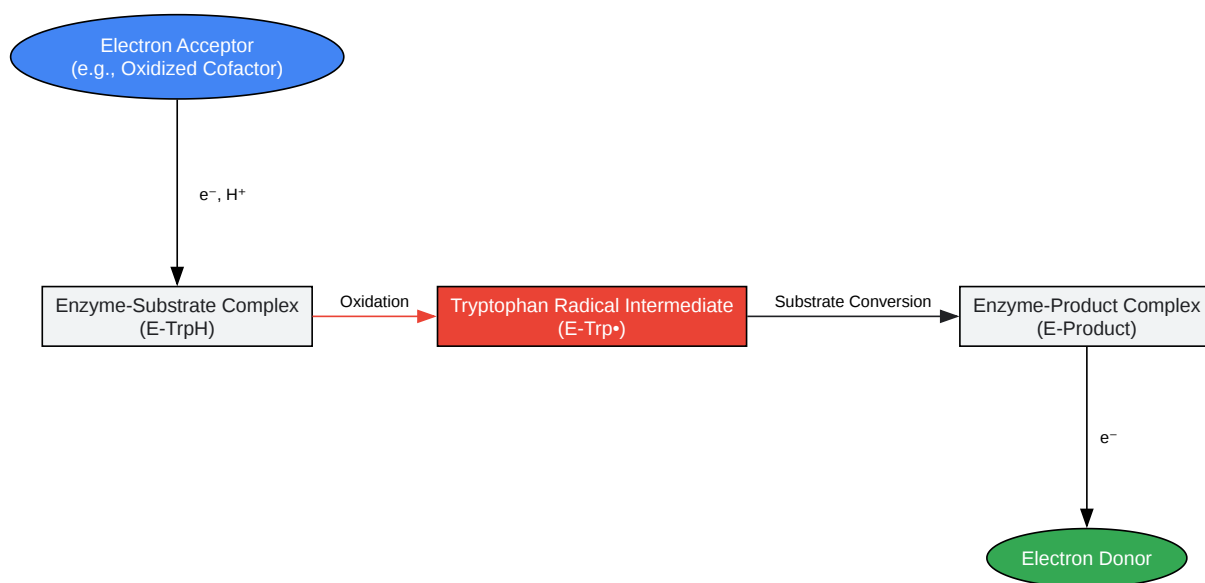

[Click to download full resolution via product page](#)

Caption: Generalized enzymatic cycle involving a **tryptophan radical** intermediate.

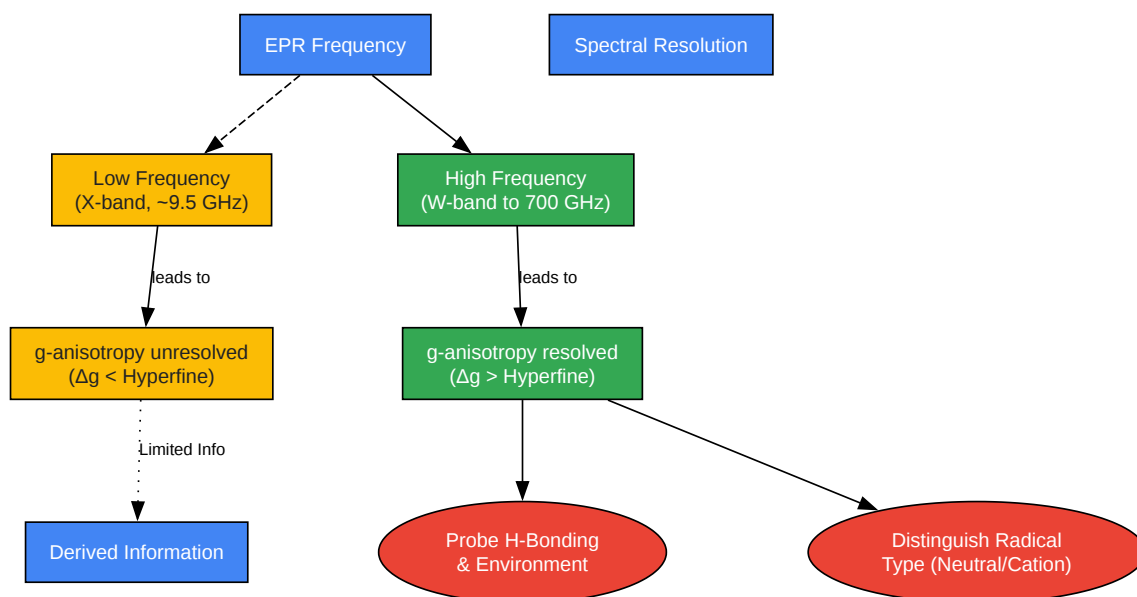

[Click to download full resolution via product page](#)

Caption: Relationship between EPR frequency, resolution, and obtainable information.

Need Custom Synthesis?

BenchChem offers custom synthesis for rare earth carbides and specific isotopic labeling.

Email: info@benchchem.com or [Request Quote Online](#).

References

- 1. High-Frequency/High-Field EPR and Theoretical Studies of Tryptophan-Based Radicals - PMC [[pmc.ncbi.nlm.nih.gov](https://pubmed.ncbi.nlm.nih.gov/)]
- 2. nationalmaglab.org [nationalmaglab.org]

- [3. Hydrogen bonding of tryptophan radicals revealed by EPR at 700 GHz - PMC \[pmc.ncbi.nlm.nih.gov\]](#)
- [4. depts.washington.edu \[depts.washington.edu\]](#)
- [5. researchgate.net \[researchgate.net\]](#)
- [6. researchgate.net \[researchgate.net\]](#)
- [7. ethz.ch \[ethz.ch\]](#)
- [8. researchgate.net \[researchgate.net\]](#)
- [9. I-Tryptophan Radical Cation Electron Spin Resonance Studies: Connecting Solution-derived Hyperfine Coupling Constants with Protein Spectral Interpretations - PMC \[pmc.ncbi.nlm.nih.gov\]](#)
- To cite this document: BenchChem. [Application Note: Characterization of Tryptophan Radical g-Tensors using EPR Spectroscopy]. BenchChem, [2026]. [Online PDF]. Available at: [<https://www.benchchem.com/product/b1237849/docs#application-note-characterization-of-tryptophan-radical-g-tensors-using-epr-spectroscopy>]

Disclaimer & Data Validity:

The information provided in this document is for Research Use Only (RUO) and is strictly not intended for diagnostic or therapeutic procedures. While BenchChem strives to provide accurate protocols, we make no warranties, express or implied, regarding the fitness of this product for every specific experimental setup.

Technical Support: The protocols provided are for reference purposes. Unsure if this reagent suits your experiment?

Need Industrial/Bulk Grade? [Request Custom Synthesis Quote](#)

BenchChem

Our mission is to be the trusted global source of essential and advanced chemicals, empowering scientists and researchers to drive progress in science and industry.

Contact

Address: 3281 E Guasti Rd
Ontario, CA 91761, United States
Phone: (601) 213-4426
Email: info@benchchem.com

Contact our Ph.D. Support Team for a compatibility check