

A Comparative Analysis of Tryptophan Radical Formation in Key Enzyme Families

Author: BenchChem Technical Support Team. **Date:** April 2026

Compound of Interest

Compound Name: *Tryptophan radical*

Cat. No.: *B1237849*

[Get Quote](#)

For researchers, scientists, and drug development professionals, understanding the nuances of radical chemistry within biological systems is paramount. This guide provides a detailed comparison of **tryptophan radical** formation across three vital enzyme families: Ribonucleotide Reductases (RNRs), Peroxidases, and Photosynthetic Enzymes. By presenting quantitative data, detailed experimental protocols, and clear visual pathways, this document serves as a comprehensive resource for investigating and targeting these crucial enzymatic mechanisms.

Introduction

Tryptophan, an essential amino acid, plays a multifaceted role in protein structure and function. Beyond its contribution to protein architecture, the indole side chain of tryptophan can be oxidized to form a transient but functionally critical tryptophanyl radical. This reactive intermediate participates in a variety of enzymatic reactions, often facilitating long-range electron transfer (ET) processes that are central to catalysis. This guide explores the similarities and differences in the generation, properties, and functional roles of **tryptophan radicals** in ribonucleotide reductases, peroxidases, and photosynthetic enzymes, offering insights into the diverse strategies nature employs to harness the power of this potent redox cofactor.

Quantitative Comparison of Tryptophan Radical Properties

The local protein environment significantly influences the spectroscopic and electrochemical properties of **tryptophan radicals**. Key parameters such as g-values and hyperfine coupling constants, determined by Electron Paramagnetic Resonance (EPR) spectroscopy, provide a fingerprint for the radical's electronic structure and its interaction with the surrounding matrix. Redox potentials indicate the thermodynamic feasibility of radical formation.

Enzyme Family	Specific Enzyme (Organism)	Tryptophan Residue	g-values (g _{iso})	Major Hyperfine Couplings (MHz)	Redox Potential (E°)	Reference
Ribonucleotide Reductase	E. coli RNR (Y122F mutant)	Trp122	g _x = 2.0034, g _y = 2.0026, g _z = 2.0022	A(N1) ≈ 8.4, A(Hβ1) ≈ 14.6, A(Hβ2) ≈ 6.7	-	[1][2]
E. coli RNR (Y356W mutant)	Trp356	Not reported	Not reported	Rate of formation: (4.4 ± 0.2) × 10 ⁵ s ⁻¹	[3][4]	
Peroxidases	Versatile Peroxidase (Bjerkandera adusta)	Trp164	g _{iso} ≈ 2.0027	A(N1) ≈ 8.7, A(Hβ1) ≈ 13.5, A(Hβ2) ≈ 7.3	Not reported	[5][6][7]
Cytochrome c Peroxidase (Saccharomyces cerevisiae)	Trp191	Not directly measured due to coupling with heme	-	≤ 0.740 V	[8]	
Photosynthetic Enzymes	Photosystem II (Spinach)	Multiple Trp residues	Not reported for a specific radical	Not reported	D1-Trp14 is easily oxidizable (low E _m)	[9][10]

Table 1: Comparative quantitative data for **tryptophan radicals** across different enzyme families. This table summarizes key spectroscopic and electrochemical parameters for

tryptophan radicals identified in ribonucleotide reductases, peroxidases, and photosynthetic enzymes.

Tryptophan Radical Formation Pathways

The mechanisms of **tryptophan radical** formation are intricately linked to the overall catalytic cycle of each enzyme. While the initial trigger for oxidation differs, the subsequent involvement of the tryptophanyl radical in electron transfer cascades is a common theme.

Ribonucleotide Reductase (Class Ia)

In Class Ia RNRs, a stable tyrosyl radical (Y122•) in the $\beta 2$ subunit initiates a long-range radical transfer (RT) process to the active site in the $\alpha 2$ subunit. In engineered mutants where the native tyrosines are replaced, tryptophan can participate in this pathway.

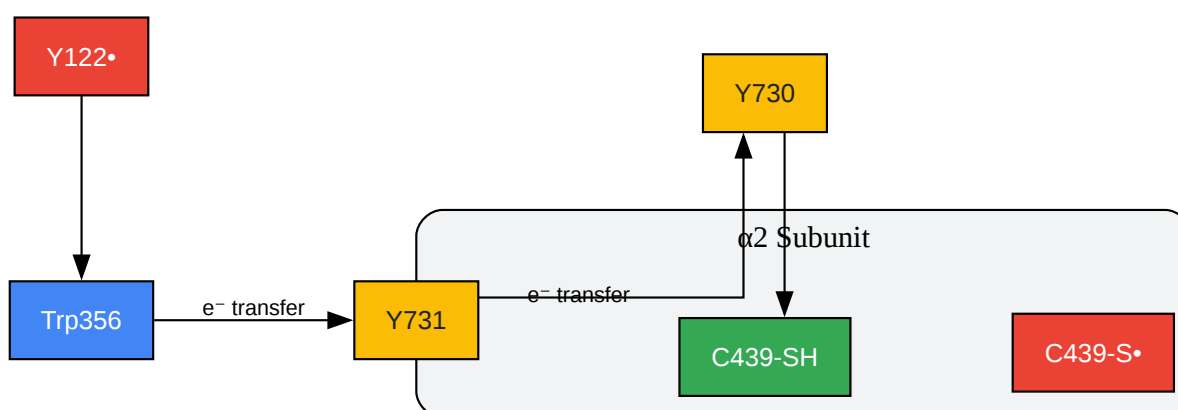

[Click to download full resolution via product page](#)

Figure 1: Radical Transfer Pathway in E. coli Ribonucleotide Reductase. This diagram illustrates the proposed radical hopping mechanism from the initial tyrosyl radical (or an engineered **tryptophan radical**) in the $\beta 2$ subunit to the active site cysteine in the $\alpha 2$ subunit. [11][12][13][14]

Peroxidases (Versatile Peroxidase)

Versatile Peroxidases (VPs) utilize a heme cofactor that is first oxidized by hydrogen peroxide to a high-valent iron-oxo species (Compound I). In many VPs, an electron is abstracted from a

nearby tryptophan residue to form a tryptophanyl radical, which then participates in the oxidation of bulky substrates that cannot directly access the heme active site.

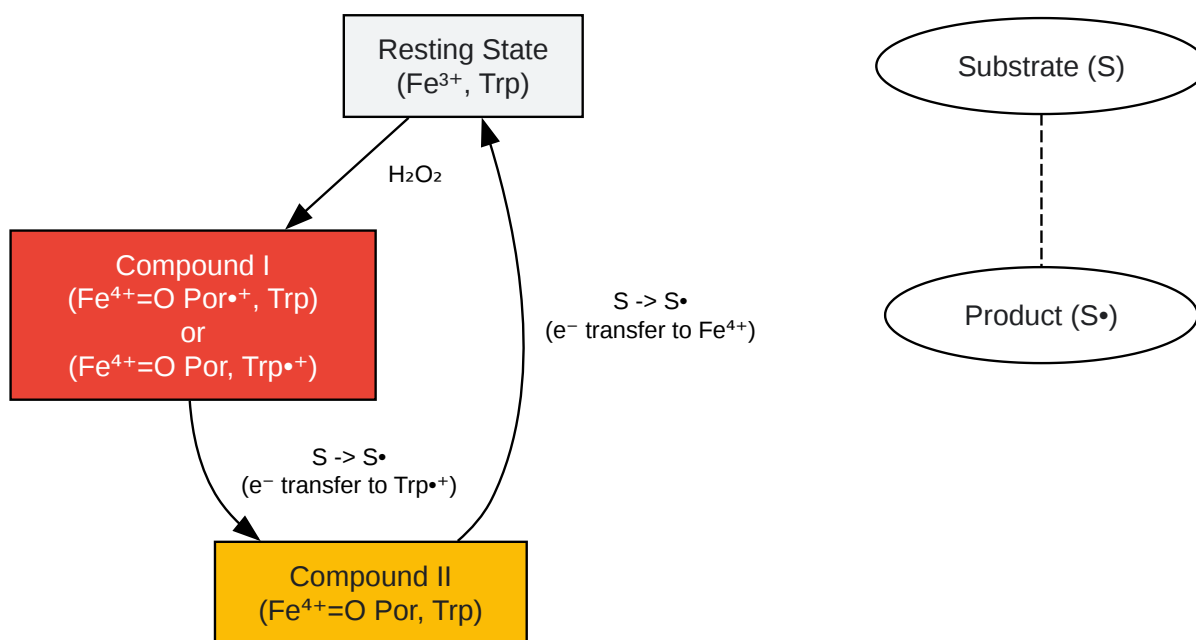

[Click to download full resolution via product page](#)

Figure 2: Catalytic Cycle of Versatile Peroxidase. This diagram shows the formation of a **tryptophan radical** in Compound I and its role in substrate oxidation.[5][6][15]

Photosynthetic Enzymes (Photosystem II)

In Photosystem II (PSII), light-induced charge separation generates a powerful oxidant, P680⁺. While tyrosine radicals (Yz[•] and Yd[•]) are the well-established redox intermediates, tryptophan residues are also susceptible to oxidation, particularly under conditions of photo-oxidative stress. This oxidation can lead to protein damage and degradation, a key aspect of the PSII repair cycle. The exact pathway of **tryptophan radical** formation is less defined than in RNRs and peroxidases but is thought to be initiated by reactive oxygen species (ROS) generated during photosynthesis.

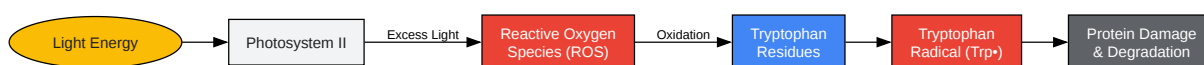

[Click to download full resolution via product page](#)

Figure 3: Tryptophan Oxidation in Photosystem II. This workflow illustrates the proposed mechanism of tryptophan oxidation in PSII, initiated by ROS under high-light stress.[10][16]

Key Experimental Protocols

The characterization of **tryptophan radicals** relies heavily on a combination of spectroscopic and molecular biology techniques.

Electron Paramagnetic Resonance (EPR) Spectroscopy

EPR is the most direct method for detecting and characterizing paramagnetic species like **tryptophan radicals**.

Objective: To detect and characterize the **tryptophan radical** in an enzyme sample.

Methodology:

- Sample Preparation:
 - Purify the enzyme of interest to homogeneity.
 - For enzymes like RNR mutants or peroxidases, the radical is generated by adding a specific trigger (e.g., Fe^{2+} and O_2 for RNR mutants, H_2O_2 for peroxidases).[1][5]
 - The reaction is typically quenched by rapid freezing in liquid nitrogen to trap the radical intermediate.
 - Samples are loaded into EPR tubes, ensuring they are free of air bubbles.
- EPR Data Acquisition:
 - Continuous-wave (CW) X-band (9.5 GHz) EPR is a common starting point.
 - Spectra are recorded at cryogenic temperatures (e.g., 77 K) to prevent radical decay and reduce spin-lattice relaxation.

- Key acquisition parameters to optimize include microwave power, modulation amplitude, and receiver gain. Power saturation studies can provide information about the radical's environment and proximity to other paramagnetic centers.[5]
- For higher resolution of g-anisotropy and hyperfine couplings, high-field/high-frequency EPR (e.g., 94 GHz) is employed.[1]
- Data Analysis:
 - The g-value is determined by including a standard with a known g-value in the measurement.
 - Hyperfine coupling constants are extracted by simulating the experimental spectrum using software packages that model the interactions of the unpaired electron with nearby magnetic nuclei (e.g., ^{14}N of the indole ring and specific protons).[7]

Site-Directed Mutagenesis

This technique is crucial for identifying the specific tryptophan residue involved in radical formation and for probing the roles of other amino acids in the radical transfer pathway.

Objective: To substitute a specific tryptophan residue with a non-redox-active amino acid (e.g., phenylalanine or alanine) to confirm its role in radical formation.

Methodology:

- Primer Design: Design complementary oligonucleotide primers containing the desired mutation. The mutation should be centrally located and flanked by 10-15 bases of correct sequence on both sides.
- Mutagenesis PCR:
 - Use a high-fidelity DNA polymerase to minimize secondary mutations.
 - Perform thermal cycling to denature the plasmid DNA, anneal the mutagenic primers, and extend the primers with the polymerase, resulting in a nicked circular plasmid containing the mutation.

- Template DNA Digestion:
 - Digest the parental, methylated, non-mutated plasmid DNA with the restriction enzyme DpnI, which specifically cleaves methylated and hemimethylated DNA. The newly synthesized, mutated DNA is not methylated and remains intact.
- Transformation and Selection:
 - Transform the DpnI-treated plasmid into competent E. coli cells.
 - Select for transformed cells on antibiotic-containing agar plates.
- Verification:
 - Isolate plasmid DNA from several colonies.
 - Verify the presence of the desired mutation and the absence of any unwanted mutations by DNA sequencing.
 - Express and purify the mutant protein and confirm the absence of the **tryptophan radical** signal by EPR spectroscopy after attempting to generate it.[15]

Conclusion

The formation of **tryptophan radicals** is a critical event in the catalytic cycles of diverse enzyme families. In ribonucleotide reductases and peroxidases, these radicals are integral components of sophisticated long-range electron transfer pathways essential for catalysis. In photosynthetic systems, tryptophan oxidation appears to be more of a consequence of oxidative stress, playing a role in the protein quality control machinery. The comparative analysis presented here, including quantitative data, mechanistic pathways, and experimental methodologies, provides a valuable framework for researchers seeking to further unravel the intricate roles of **tryptophan radicals** in biological redox chemistry and to leverage this knowledge for applications in biotechnology and drug development.

Need Custom Synthesis?

BenchChem offers custom synthesis for rare earth carbides and specific isotopic labeling.

Email: info@benchchem.com or [Request Quote Online](#).

References

- 1. Tryptophan and tyrosine radicals in ribonucleotide reductase: a comparative high-field EPR study at 94 GHz - PubMed [pubmed.ncbi.nlm.nih.gov]
- 2. pubs.acs.org [pubs.acs.org]
- 3. Photochemical Generation of a Tryptophan Radical within the Subunit Interface of Ribonucleotide Reductase - PMC [pmc.ncbi.nlm.nih.gov]
- 4. Photochemical Generation of a Tryptophan Radical within the Subunit Interface of Ribonucleotide Reductase - PubMed [pubmed.ncbi.nlm.nih.gov]
- 5. Tryptophan-based radical in the catalytic mechanism of versatile peroxidase from *Bjerkandera adusta* [pubmed.ncbi.nlm.nih.gov]
- 6. pubs.acs.org [pubs.acs.org]
- 7. researchgate.net [researchgate.net]
- 8. Computational analysis of the tryptophan cation radical energetics in peroxidase Compound I - PMC [pmc.ncbi.nlm.nih.gov]
- 9. Energetics of tryptophan residues in electron transfer and photoprotection of type-II photosynthetic reaction centers - PMC [pmc.ncbi.nlm.nih.gov]
- 10. Characterization of tryptophan oxidation affecting D1 degradation by FtsH in the photosystem II quality control of chloroplasts - PMC [pmc.ncbi.nlm.nih.gov]
- 11. pnas.org [pnas.org]
- 12. pubs.acs.org [pubs.acs.org]
- 13. Reversible, long-range radical transfer in *E. coli* class Ia ribonucleotide reductase - PubMed [pubmed.ncbi.nlm.nih.gov]
- 14. dspace.mit.edu [dspace.mit.edu]
- 15. Protein radicals in fungal versatile peroxidase: catalytic tryptophan radical in both compound I and compound II and studies on W164Y, W164H, and W164S variants - PubMed [pubmed.ncbi.nlm.nih.gov]
- 16. Characterization of Tryptophan Oxidation Affecting D1 Degradation by FtsH in the Photosystem II Quality Control of Chloroplasts [elifesciences.org]
- To cite this document: BenchChem. [A Comparative Analysis of Tryptophan Radical Formation in Key Enzyme Families]. BenchChem, [2026]. [Online PDF]. Available at: [<https://www.benchchem.com/product/b1237849/docs#a-comparative-analysis-of-tryptophan-radical-formation-in-key-enzyme-families>]

Disclaimer & Data Validity:

The information provided in this document is for Research Use Only (RUO) and is strictly not intended for diagnostic or therapeutic procedures. While BenchChem strives to provide accurate protocols, we make no warranties, express or implied, regarding the fitness of this product for every specific experimental setup.

Technical Support: The protocols provided are for reference purposes. Unsure if this reagent suits your experiment?

Need Industrial/Bulk Grade? [Request Custom Synthesis Quote](#)

BenchChem

Our mission is to be the trusted global source of essential and advanced chemicals, empowering scientists and researchers to drive progress in science and industry.

Contact

Address: 3281 E Guasti Rd
Ontario, CA 91761, United States
Phone: (601) 213-4426
Email: info@benchchem.com

[Contact our Ph.D. Support Team for a compatibility check](#)