

Technical Support Center: IVMT-Rx-3

Experimental Setup

Author: BenchChem Technical Support Team. **Date:** April 2026

Compound of Interest

Compound Name: IVMT-Rx-3

Cat. No.: B12369662

[Get Quote](#)

This technical support center provides troubleshooting guides and frequently asked questions (FAQs) for researchers, scientists, and drug development professionals working with **IVMT-Rx-3**, a dual-PDZ domain inhibitor of MDA-9/Syntenin.

Frequently Asked Questions (FAQs)

Q1: What is **IVMT-Rx-3** and what is its primary mechanism of action?

A: **IVMT-Rx-3** is a novel inhibitor that simultaneously targets both the PDZ1 and PDZ2 domains of the MDA-9/Syntenin protein.^{[1][2]} It is a peptide-small molecule conjugate, designed to maximize the disruption of MDA-9/Syntenin signaling.^{[1][2]} Its primary mechanism of action involves blocking the interaction of MDA-9/Syntenin with Src, which in turn reduces the activation of NF-κB and inhibits the expression of matrix metalloproteinases MMP-2 and MMP-9.^{[1][2]} This cascade of events ultimately leads to the repression of melanoma metastasis.^{[1][2]}

Q2: In which experimental models has **IVMT-Rx-3** been utilized?

A: **IVMT-Rx-3** has been successfully used in both in vitro and in vivo experimental models. In vitro studies have commonly employed established human melanoma cell lines such as A-375, C8161.9, and MeWo. For in vivo studies, **IVMT-Rx-3** has been tested in mouse models of

experimental metastasis, where it has been shown to significantly reduce the formation of lung nodules.

Q3: What is the molecular composition of **IVMT-Rx-3**?

A: **IVMT-Rx-3** is a bivalent molecule. It is composed of a small molecule inhibitor of the PDZ1 domain (PDZ1i) joined to a peptide that binds to the second PDZ domain (TNYYFV) via a PEG linker.^{[1][2]} This design allows for the simultaneous engagement and inhibition of both PDZ domains of MDA-9/Syntenin.^{[1][2]}

Troubleshooting Guides

This section provides solutions to common challenges that may be encountered during the experimental setup and execution of studies involving **IVMT-Rx-3**.

In Vitro Assays

Issue 1: Inconsistent or no effect of **IVMT-Rx-3** on cell invasion in Transwell assays.

Potential Cause	Troubleshooting Step
Suboptimal Cell Seeding Density	Determine the optimal cell density for your specific cell line by performing a titration experiment. Too few cells can lead to inconsistent results, while too many can oversaturate the pores of the membrane.[3]
Incorrect Chemoattractant Concentration	Titrate the chemoattractant concentration to find the optimal level for inducing migration in your cell line. If no prior data is available, a good starting point for serum is 10%.
Inappropriate Incubation Time	Optimize the incubation time for your assay. This is cell-type dependent, but a typical starting point is 16-24 hours.
Extracellular Matrix (ECM) Barrier Issues	If using an invasion assay, ensure the ECM gel is properly prepared and coated on the inserts. Include a control with a low-invasion cell line to verify the barrier's effectiveness.[3]
IVMT-Rx-3 Solubility or Stability	As a peptide-small molecule conjugate, IVMT-Rx-3 may have specific solubility and stability requirements. Ensure it is properly dissolved and stored according to the manufacturer's instructions. Peptides can be susceptible to degradation, so handle them with care.[4][5]

Issue 2: Difficulty in monitoring the downstream effects of **IVMT-Rx-3** on signaling pathways.

Potential Cause	Troubleshooting Step
Low Signal-to-Noise Ratio in NF- κ B Activation Assays	For monitoring NF- κ B activation, consider using a sensitive method like a luciferase reporter assay.[6][7][8] When performing Western blots for phosphorylated proteins, ensure the use of appropriate inhibitors of phosphatases during cell lysis.
Variability in MMP-2/MMP-9 Expression or Activity	For analyzing MMP expression, qPCR can be a sensitive method. For MMP activity, gelatin zymography is a standard and effective technique.[9] Be aware that MMP expression and activity can be influenced by various factors in the cell culture environment.[10][11]
Antibody Performance in Western Blots	Validate the specificity and sensitivity of your primary antibodies for all target proteins (e.g., phospho-Src, NF- κ B subunits, MMPs).

In Vivo Assays

Issue 3: High variability or lack of significant effect of **IVMT-Rx-3** in mouse models of metastasis.

Potential Cause	Troubleshooting Step
Inappropriate Mouse Model	The choice between a syngeneic or xenograft model is critical. Syngeneic models are better for studying the interaction with an intact immune system, while xenograft models use human cells but require immunocompromised mice.[1][12]
Injection Site and Procedure	The route of injection (e.g., tail vein, intracardiac, orthotopic) will influence the site of metastasis.[1] Standardize the injection procedure to minimize variability between animals.
Tumor Cell Heterogeneity	The metastatic potential of cell lines can vary. Ensure you are using a cell line with a known and consistent metastatic phenotype.[13]
IVMT-Rx-3 Dosing and Administration	Optimize the dose, frequency, and route of administration of IVMT-Rx-3 for your specific model. Consider the pharmacokinetic properties of peptide-small molecule conjugates, which can have rapid metabolism.[5]
Lack of a Tumor Microenvironment	Ectopic implantation models may not fully recapitulate the natural tumor microenvironment. Orthotopic implantation is more complex but can provide a more relevant context.[12]

Experimental Protocols & Visualizations

IVMT-Rx-3 Signaling Pathway

The following diagram illustrates the signaling pathway inhibited by **IVMT-Rx-3**.

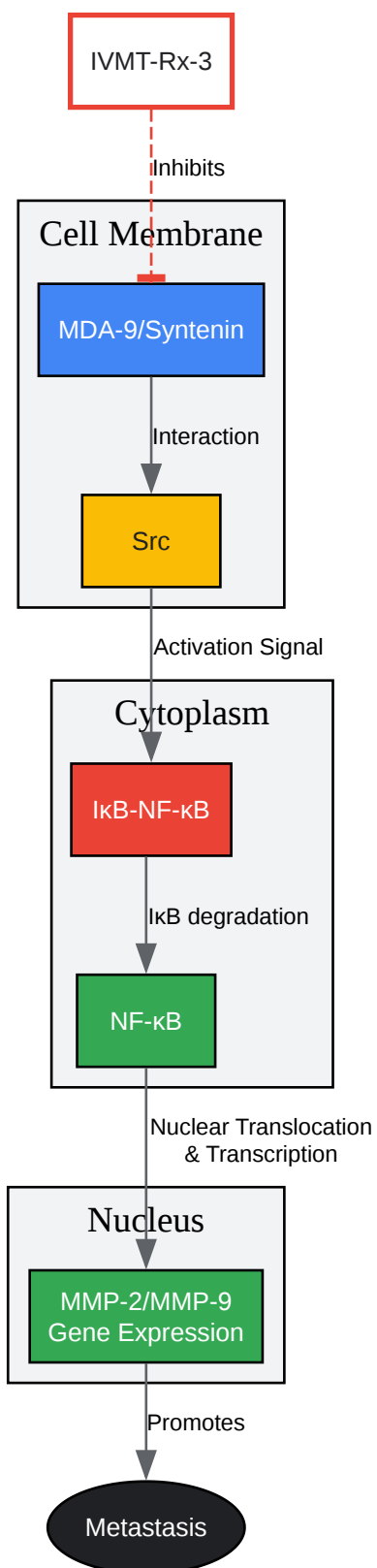

[Click to download full resolution via product page](#)

Caption: **IVMT-Rx-3** inhibits the MDA-9/Syntenin signaling pathway, leading to reduced metastasis.

Experimental Workflow: In Vitro Invasion Assay

The following diagram outlines a typical workflow for an in vitro invasion assay using **IVMT-Rx-3**.

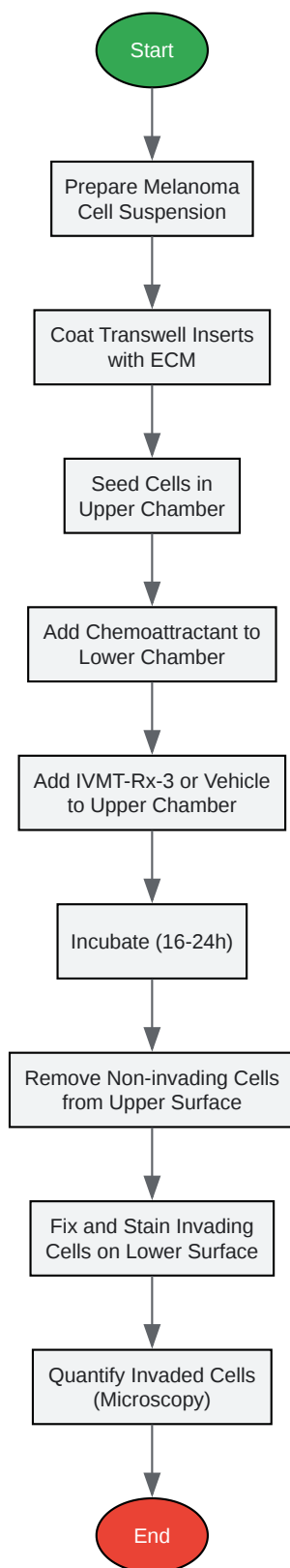

[Click to download full resolution via product page](#)

Caption: A generalized workflow for conducting an in vitro cell invasion assay with **IVMT-Rx-3**.

Need Custom Synthesis?

BenchChem offers custom synthesis for rare earth carbides and specific isotopic labeling.

Email: info@benchchem.com or [Request Quote Online](#).

References

- [1. academic.oup.com \[academic.oup.com\]](https://academic.oup.com)
- [2. Dual Targeting of the PDZ1 and PDZ2 Domains of MDA-9/Syntenin Inhibits Melanoma Metastasis - PubMed \[pubmed.ncbi.nlm.nih.gov\]](#)
- [3. corning.com \[corning.com\]](https://www.corning.com)
- [4. creative-diagnostics.com \[creative-diagnostics.com\]](https://www.creative-diagnostics.com)
- [5. labtesting.wuxiapptec.com \[labtesting.wuxiapptec.com\]](https://www.labtesting.wuxiapptec.com)
- [6. Real-time monitoring of NF-kappaB activity in cultured cells and in animal models - PMC \[pmc.ncbi.nlm.nih.gov\]](#)
- [7. Challenges with Methods for Detecting and Studying the Transcription Factor Nuclear Factor Kappa B \(NF-κB\) in the Central Nervous System - PMC \[pmc.ncbi.nlm.nih.gov\]](#)
- [8. scienceopen.com \[scienceopen.com\]](https://www.scienceopen.com)
- [9. Differential Expression of MMP-2 and -9 and their Inhibitors in Fetal Lung Cells Exposed to Mechanical Stretch: Regulation by IL-10 - PMC \[pmc.ncbi.nlm.nih.gov\]](#)
- [10. mdpi.com \[mdpi.com\]](https://www.mdpi.com)
- [11. Comparison of MMP-2 and MMP-9 secretion from T helper 0, 1 and 2 lymphocytes alone and in coculture with macrophages - PMC \[pmc.ncbi.nlm.nih.gov\]](#)
- [12. Modeling metastasis in mice: a closer look - PMC \[pmc.ncbi.nlm.nih.gov\]](#)
- [13. Mouse models of metastasis: progress and prospects - PMC \[pmc.ncbi.nlm.nih.gov\]](#)
- To cite this document: BenchChem. [Technical Support Center: IVMT-Rx-3 Experimental Setup]. BenchChem, [2026]. [Online PDF]. Available at: [\[https://www.benchchem.com/product/b12369662/docs#technical-support-center-ivmt-rx-3-experimental-setup\]](https://www.benchchem.com/product/b12369662/docs#technical-support-center-ivmt-rx-3-experimental-setup)

Disclaimer & Data Validity:

The information provided in this document is for Research Use Only (RUO) and is strictly not intended for diagnostic or therapeutic procedures. While BenchChem strives to provide accurate protocols, we make no warranties, express or implied, regarding the fitness of this product for every specific experimental setup.

Technical Support: The protocols provided are for reference purposes. Unsure if this reagent suits your experiment?

Need Industrial/Bulk Grade? [Request Custom Synthesis Quote](#)

BenchChem

Our mission is to be the trusted global source of essential and advanced chemicals, empowering scientists and researchers to drive progress in science and industry.

Contact

Address: 3281 E Guasti Rd
Ontario, CA 91761, United States
Phone: (601) 213-4426
Email: info@benchchem.com

[Contact our Ph.D. Support Team for a compatibility check](#)