

# Essential Safety and Operational Guide for Handling CK2-IN-11

**Author:** BenchChem Technical Support Team. **Date:** April 2026

## Compound of Interest

Compound Name: CK2-IN-11

Cat. No.: B12369572

[Get Quote](#)

This document provides immediate and essential safety and logistical information for researchers, scientists, and drug development professionals handling the casein kinase 2 (CK2) inhibitor, **CK2-IN-11**. It includes detailed operational and disposal plans to ensure the safe and effective use of this compound in a laboratory setting.

## Personal Protective Equipment (PPE) and Safety Precautions

Disclaimer: A specific Safety Data Sheet (SDS) for **CK2-IN-11** was not publicly available at the time of this writing. The following recommendations are based on the SDS for a similar CK2 inhibitor and general best practices for handling chemical compounds in a laboratory environment. Users should always consult the specific SDS provided by the supplier before handling any chemical.

Proper PPE is the first line of defense against potential exposure to **CK2-IN-11**. The following table summarizes the recommended PPE for various laboratory operations.

Operation	Recommended Personal Protective Equipment
Weighing and Preparing Solutions	- Chemical-resistant gloves (e.g., nitrile) - Safety glasses with side shields or chemical splash goggles - Laboratory coat - Respiratory protection (e.g., N95 respirator or use of a chemical fume hood) to avoid inhalation of powder.
Cell Culture and In Vitro Assays	- Chemical-resistant gloves - Safety glasses - Laboratory coat
In Vivo Studies	- Chemical-resistant gloves - Safety glasses or face shield - Laboratory coat or disposable gown - Respiratory protection may be required depending on the route of administration and potential for aerosolization.
Waste Disposal	- Chemical-resistant gloves - Safety glasses - Laboratory coat

## Operational Plan: Step-by-Step Handling Procedures

Adherence to a strict operational plan is crucial for minimizing risks and ensuring the integrity of experiments.

### Receiving and Storage

- **Inspection:** Upon receipt, visually inspect the container for any damage or leaks.
- **Storage Conditions:** Store **CK2-IN-11** in a tightly sealed container in a cool, dry, and well-ventilated area, away from incompatible materials such as strong oxidizing agents. Recommended storage temperature is typically -20°C for long-term stability.
- **Labeling:** Ensure the container is clearly labeled with the chemical name, concentration, date received, and any hazard warnings.

## Preparation of Stock Solutions

- **Work Area:** All weighing and solution preparation should be conducted in a designated area, preferably within a chemical fume hood to minimize inhalation exposure.
- **Dissolving the Compound:** **CK2-IN-11** is typically dissolved in a suitable solvent such as Dimethyl Sulfoxide (DMSO).
- **Procedure:**
  - Ensure all necessary PPE is worn.
  - Calculate the required amount of **CK2-IN-11** and solvent to achieve the desired stock concentration.
  - Carefully weigh the powdered compound using a calibrated analytical balance.
  - Slowly add the solvent to the powder in a sterile, conical tube or vial.
  - Vortex or sonicate the solution until the compound is completely dissolved.
  - Label the stock solution container with the compound name, concentration, solvent, date of preparation, and your initials.
  - Store the stock solution at the recommended temperature, typically -20°C or -80°C, in small aliquots to avoid repeated freeze-thaw cycles.

## Use in Experiments

- **Dilutions:** Prepare working dilutions from the stock solution immediately before use. Dilute the stock solution in the appropriate cell culture medium or buffer.
- **Handling:** When adding the compound to cell cultures or experimental systems, use appropriate pipetting techniques to avoid splashes or aerosols.
- **Incubation:** After treatment, incubate cells or experimental systems under the specified conditions.

## Disposal Plan

Proper disposal of **CK2-IN-11** and contaminated materials is essential to prevent environmental contamination and ensure laboratory safety.

Waste Type	Disposal Procedure
Unused CK2-IN-11 Powder	- Dispose of as hazardous chemical waste in accordance with local, state, and federal regulations. - Do not dispose of down the drain or in regular trash.
Stock Solutions and Working Solutions	- Collect all solutions containing CK2-IN-11 in a designated, labeled hazardous waste container. - The container should be made of a compatible material (e.g., glass or polyethylene).
Contaminated Labware (e.g., pipette tips, tubes)	- Dispose of in a designated solid hazardous waste container.
Contaminated Cell Culture Media	- Aspirate the media and collect it in a labeled hazardous waste container. - Alternatively, treat the media with a suitable chemical disinfectant (e.g., bleach) before disposal down the sanitary sewer, if permitted by local regulations.
Contaminated PPE (gloves, disposable lab coats)	- Dispose of in a designated solid hazardous waste container.

## CK2 Signaling Pathway

Protein Kinase CK2 is a constitutively active serine/threonine kinase that plays a crucial role in various cellular processes by phosphorylating a wide range of substrate proteins. Its activity is implicated in several key signaling pathways that are often dysregulated in diseases like cancer. **CK2-IN-11**, as an inhibitor, is designed to modulate these pathways.

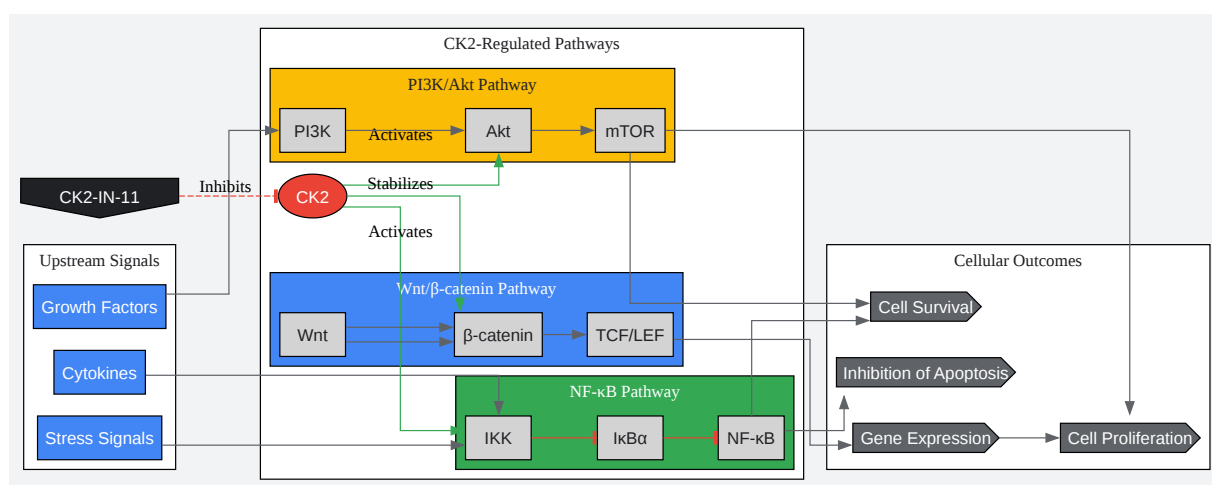

[Click to download full resolution via product page](#)

- To cite this document: BenchChem. [Essential Safety and Operational Guide for Handling CK2-IN-11]. BenchChem, [2026]. [Online PDF]. Available at: [\[https://www.benchchem.com/product/b12369572/docs#essential-safety-and-operational-guide-for-handling-ck2-in-11\]](https://www.benchchem.com/product/b12369572/docs#essential-safety-and-operational-guide-for-handling-ck2-in-11)

### Disclaimer & Data Validity:

The information provided in this document is for Research Use Only (RUO) and is strictly not intended for diagnostic or therapeutic procedures. While BenchChem strives to provide accurate protocols, we make no warranties, express or implied, regarding the fitness of this product for every specific experimental setup.

**Technical Support:** The protocols provided are for reference purposes. Unsure if this reagent suits your experiment?

**Need Industrial/Bulk Grade?** [Request Custom Synthesis Quote](#)

## BenchChem

Our mission is to be the trusted global source of essential and advanced chemicals, empowering scientists and researchers to drive progress in science and industry.

### Contact

Address: 3281 E Guasti Rd  
Ontario, CA 91761, United States  
Phone: (601) 213-4426  
Email: [info@benchchem.com](mailto:info@benchchem.com)

[Contact our Ph.D. Support Team for a compatibility check](#)