

A Comparative Guide to Adjuvants for Protein-Based Subunit Vaccines

Author: BenchChem Technical Support Team. **Date:** April 2026

Compound of Interest

Compound Name: GK83
Cat. No.: B12369761

[Get Quote](#)

For Researchers, Scientists, and Drug Development Professionals

This guide provides an objective comparison of commonly used adjuvants for protein-based subunit vaccines, supported by experimental data and detailed protocols. Given the absence of public data on a specific "GK83" antigen, this comparison utilizes data from studies with well-characterized protein antigens, such as the SARS-CoV-2 spike protein and influenza hemagglutinin, to provide a relevant and informative resource for vaccine development.

Introduction to Vaccine Adjuvants

Adjuvants are critical components of subunit vaccines, which are composed of purified antigens that are often poorly immunogenic on their own.[1] Adjuvants enhance the magnitude and durability of the immune response to a co-administered antigen.[2] They can achieve this through various mechanisms, including forming an antigen depot at the injection site for slow release, activating innate immune cells through pattern recognition receptors (PRRs), and promoting the recruitment of immune cells to the site of injection.[3][4] The choice of adjuvant can significantly influence the type of immune response generated, for instance, skewing it towards a humoral (antibody-based) or cellular (T-cell-based) response.[5]

Comparative Analysis of Adjuvant Performance

The following tables summarize quantitative data from studies comparing the efficacy of different adjuvants when formulated with a model protein antigen. These studies typically measure the humoral response (antibody titers) and the cellular response (T-cell activation and cytokine production).

Humoral Immune Response

The induction of high-titer neutralizing antibodies is a primary goal for many vaccines. The following table compares the antibody responses generated by different adjuvants when formulated with the SARS-CoV-2 spike protein.

Table 1: Comparison of Adjuvant Efficacy on Antibody Responses to SARS-CoV-2 Spike Protein in Mice

Adjuvant	Antigen-Specific IgG Titer (Geometric Mean Titer)	Neutralizing Antibody Titer (ID50)	Primary IgG Subclass	Reference
Aluminum Hydroxide	1.5×10^4	86	IgG1 (Th2-biased)	[5]
Squalene Emulsion (SE)	8.0×10^5	4063	Balanced IgG1/IgG2a	[5]
Cationic Liposomes (CAF01)	5.0×10^5	1024	IgG2a (Th1-biased)	[5]
No Adjuvant	$< 10^2$	< 20	-	[5]

Data is representative and compiled from a study using a single immunization in mice with the SARS-CoV-2 pre-fusion stabilized spike protein (S-2P).[5]

Cellular Immune Response

T-cell responses, particularly CD4+ T helper cells, are crucial for orchestrating the adaptive immune response and promoting long-lived immunity. The cytokine profile of these T cells indicates the nature of the immune response (e.g., Th1, Th2, or Th17).

Table 2: Comparison of Adjuvant Efficacy on T-Cell Responses to SARS-CoV-2 Spike Protein in Mice

Adjuvant	Dominant CD4+ T-cell Cytokine Profile	Key Cytokines Produced	Reference
Aluminum Hydroxide	Th2-biased	IL-5, IL-10	[5]
Squalene Emulsion (SE)	Balanced Th1/Th2	IFN- γ , IL-5	[5]
Cationic Liposomes (CAF01)	Th1/Th17-biased	IFN- γ , IL-17	[5]
No Adjuvant	Weak response	-	[5]

Data is representative and compiled from the same study as Table 1, assessing spike-specific CD4+ T-cell responses.[5]

Mechanisms of Action and Signaling Pathways

The diverse immunological outcomes observed with different adjuvants are a direct result of their distinct mechanisms of action.

Aluminum Hydroxide (Alum)

Alum, the most widely used adjuvant in human vaccines, is thought to work through several mechanisms.[6] It forms a depot at the injection site, facilitating antigen uptake by antigen-presenting cells (APCs).[6] Alum can also activate the NLRP3 inflammasome in APCs, leading to the release of pro-inflammatory cytokines like IL-1 β and IL-18.[7][8] This promotes a Th2-biased immune response.[8]

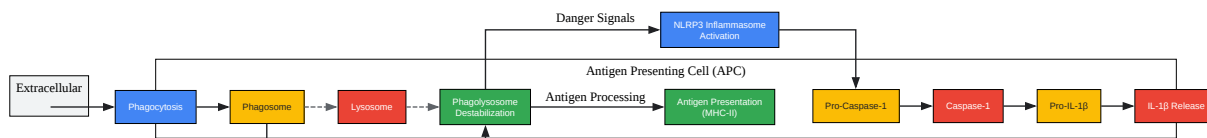

[Click to download full resolution via product page](#)

Alum Adjuvant Signaling Pathway

Oil-in-Water Emulsions (e.g., MF59, AS03, AddaVax)

Squalene-based oil-in-water emulsions like MF59, AS03, and AddaVax create a local inflammatory environment at the injection site.[9][10] This leads to the recruitment of immune cells, including monocytes and granulocytes, which differentiate into APCs.[3][9] These adjuvants enhance antigen uptake and transport to the draining lymph nodes, leading to a robust and balanced Th1/Th2 response.[9][10] The mechanism is largely independent of Toll-like receptor (TLR) signaling but involves MyD88-dependent pathways, likely downstream of cytokine receptors.[11]

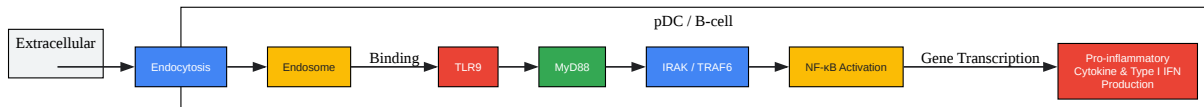
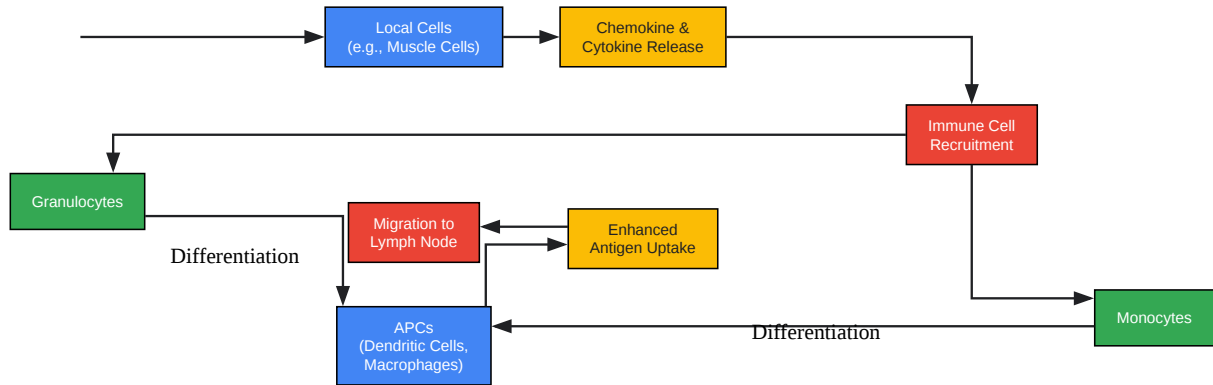

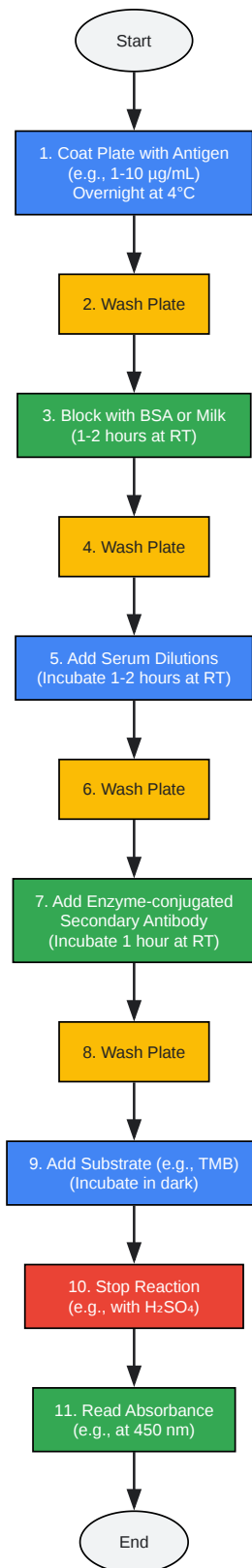

[Click to download full resolution via product page](#)

Need Custom Synthesis?

BenchChem offers custom synthesis for rare earth carbides and specific isotopic labeling.

Email: info@benchchem.com or [Request Quote Online](#).

References

- [1. academic.oup.com \[academic.oup.com\]](https://academic.oup.com)
- [2. journals.asm.org \[journals.asm.org\]](https://journals.asm.org)
- [3. Mechanisms of Action of Adjuvants - PMC \[pmc.ncbi.nlm.nih.gov\]](https://pubmed.ncbi.nlm.nih.gov/31111111/)
- [4. Comparison of Adjuvants to Optimize Influenza Neutralizing Antibody Responses - PMC \[pmc.ncbi.nlm.nih.gov\]](https://pubmed.ncbi.nlm.nih.gov/31111112/)
- [5. Adjuvanted SARS-CoV-2 spike protein elicits neutralizing antibodies and CD4 T cell responses after a single immunization in mice - PMC \[pmc.ncbi.nlm.nih.gov\]](https://pubmed.ncbi.nlm.nih.gov/31111113/)
- [6. Advances in aluminum hydroxide-based adjuvant research and its mechanism - PMC \[pmc.ncbi.nlm.nih.gov\]](https://pubmed.ncbi.nlm.nih.gov/31111114/)
- [7. pharmiweb.com \[pharmiweb.com\]](https://pharmweb.com)
- [8. Mechanism of Immunopotentiality and Safety of Aluminum Adjuvants - PMC \[pmc.ncbi.nlm.nih.gov\]](https://pubmed.ncbi.nlm.nih.gov/31111115/)
- [9. The mechanism of action of MF59 - an innately attractive adjuvant formulation - PubMed \[pubmed.ncbi.nlm.nih.gov\]](https://pubmed.ncbi.nlm.nih.gov/31111116/)
- [10. AddaVax-Adjuvanted H5N8 Inactivated Vaccine Induces Robust Humoral Immune Response against Different Clades of H5 Viruses - PMC \[pmc.ncbi.nlm.nih.gov\]](https://pubmed.ncbi.nlm.nih.gov/31111117/)
- [11. The adjuvant MF59 induces ATP release from muscle that potentiates response to vaccination - PMC \[pmc.ncbi.nlm.nih.gov\]](https://pubmed.ncbi.nlm.nih.gov/31111118/)
- To cite this document: BenchChem. [A Comparative Guide to Adjuvants for Protein-Based Subunit Vaccines]. BenchChem, [2026]. [Online PDF]. Available at: [\[https://www.benchchem.com/product/b12369761/docs#a-comparative-guide-to-adjuvants-for-protein-based-subunit-vaccines\]](https://www.benchchem.com/product/b12369761/docs#a-comparative-guide-to-adjuvants-for-protein-based-subunit-vaccines)

Disclaimer & Data Validity:

The information provided in this document is for Research Use Only (RUO) and is strictly not intended for diagnostic or therapeutic procedures. While BenchChem strives to provide accurate protocols, we make no warranties, express or implied, regarding the fitness of this product for every specific experimental setup.

Technical Support: The protocols provided are for reference purposes. Unsure if this reagent suits your experiment?

Need Industrial/Bulk Grade? [Request Custom Synthesis Quote](#)

BenchChem

Our mission is to be the trusted global source of essential and advanced chemicals, empowering scientists and researchers to drive progress in science and industry.

Contact

Address: 3281 E Guasti Rd
Ontario, CA 91761, United States
Phone: (601) 213-4426
Email: info@benchchem.com

[Contact our Ph.D. Support Team for a compatibility check](#)