

Application Notes and Protocols: Determining the Potency of BRD1652 Using Cell-Based Assays

Author: BenchChem Technical Support Team. **Date:** April 2026

Compound of Interest

Compound Name: BRD1652
Cat. No.: B12368270

[Get Quote](#)

Audience: Researchers, scientists, and drug development professionals.

Introduction

Bromodomain and Extra-Terminal Domain (BET) proteins, such as BRD2, BRD3, BRD4, and BRDT, are epigenetic readers that play a crucial role in the regulation of gene transcription.[1] These proteins recognize and bind to acetylated lysine residues on histone tails, thereby recruiting transcriptional machinery to specific gene promoters and enhancers. Dysregulation of BET protein function has been implicated in a variety of diseases, including cancer, inflammation, and cardiovascular disease. Consequently, the development of small molecule inhibitors targeting BET bromodomains is an area of intense therapeutic interest.[2][3]

BRD1652 is a novel small molecule inhibitor designed to target BET bromodomains. To characterize the pharmacological activity of **BRD1652**, it is essential to determine its potency in a cellular context. Cell-based assays are critical for this purpose as they provide a more physiologically relevant environment compared to biochemical assays and can assess not only target engagement but also downstream functional consequences of target inhibition.[4][5]

This document provides detailed protocols for a panel of cell-based assays to quantitatively determine the potency of **BRD1652**. The described assays include a cell viability assay to measure the anti-proliferative effects, a target engagement assay to confirm binding to the BET protein target within the cell, and a downstream functional assay to measure the effect on the expression of a target gene.

Signaling Pathway of BET Proteins

BET proteins, such as BRD4, bind to acetylated histones at promoter and enhancer regions of genes, including oncogenes like c-Myc. This binding facilitates the recruitment of the positive transcription elongation factor b (P-TEFb), which in turn phosphorylates RNA Polymerase II, leading to transcriptional elongation and gene expression. Inhibition of BET proteins with molecules like **BRD1652** displaces them from chromatin, leading to a downregulation of target gene expression and subsequent anti-proliferative effects.

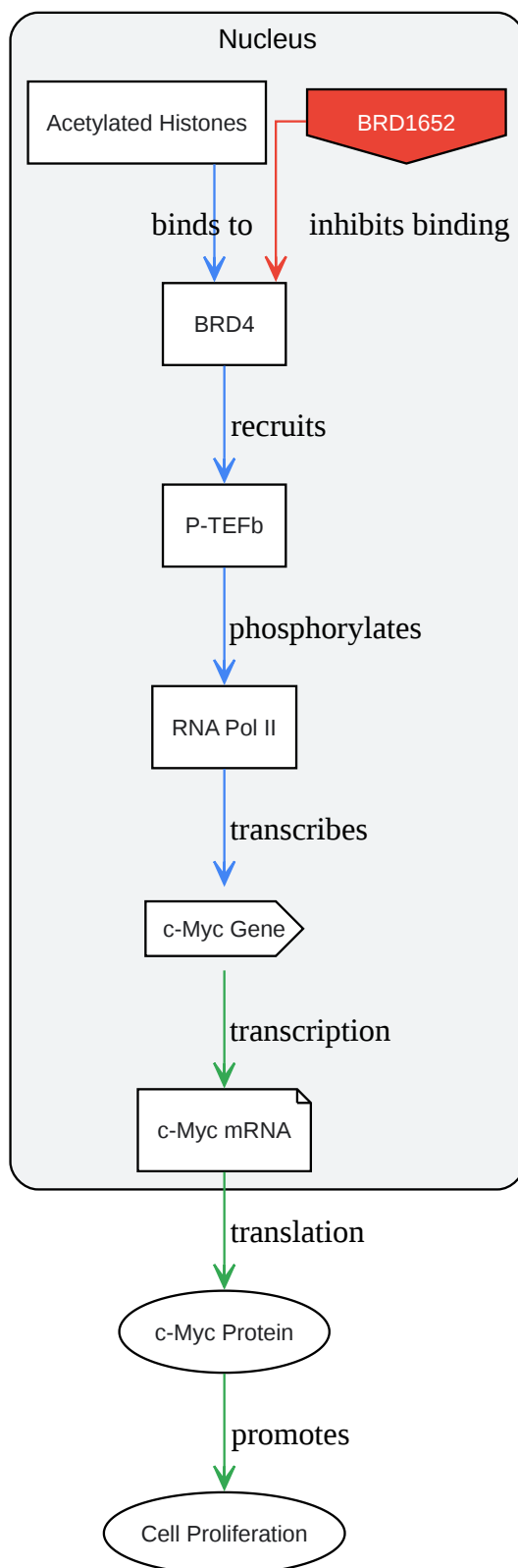

[Click to download full resolution via product page](#)

Figure 1. Simplified BET signaling pathway.

Experimental Workflow for Potency Determination

The overall workflow for determining the potency of **BRD1652** involves a series of cell-based assays, starting from a general assessment of cellular effects to specific target engagement and downstream functional readouts.

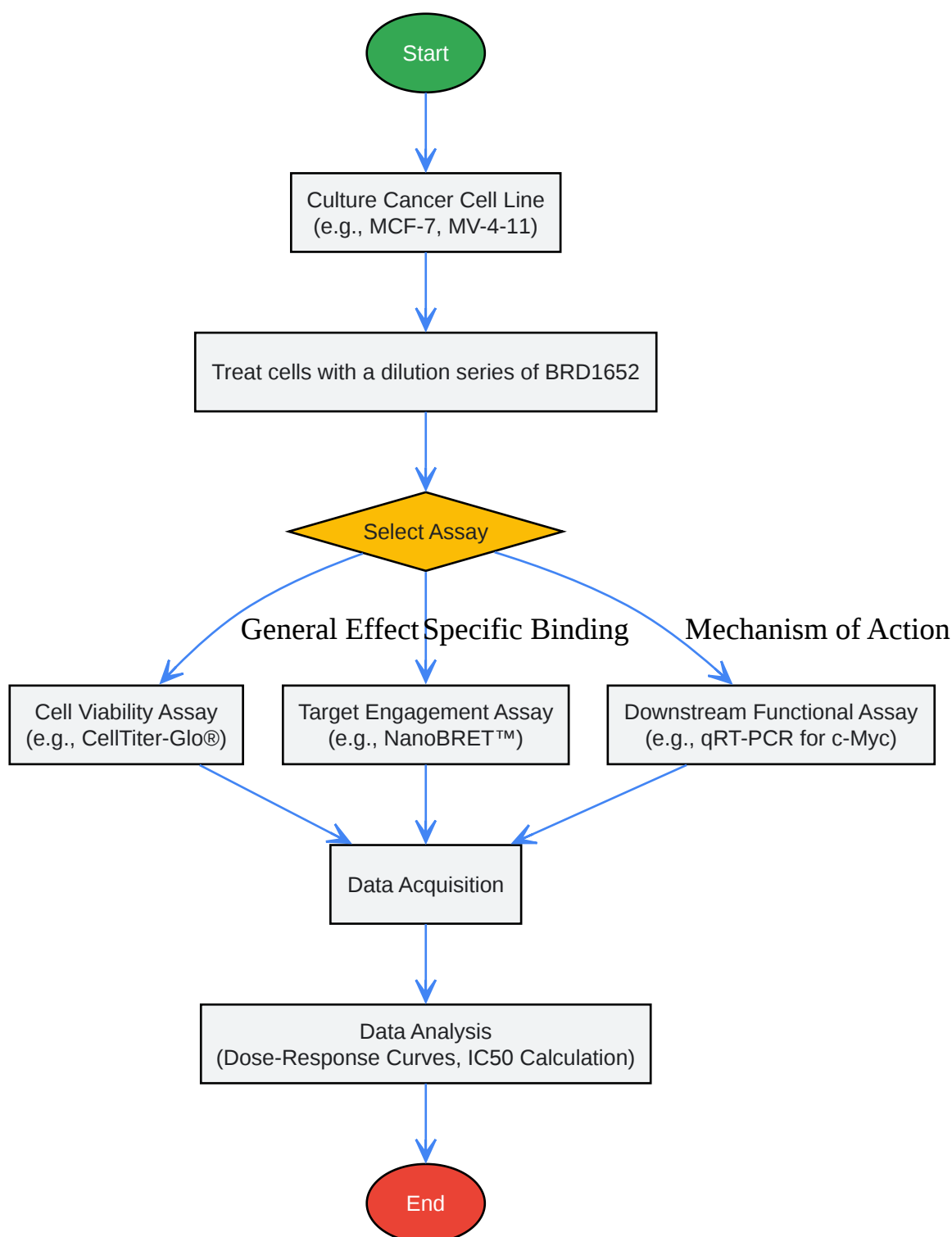

[Click to download full resolution via product page](#)

Figure 2. Experimental workflow for **BRD1652** potency assessment.

Protocols

Cell Viability Assay (Anti-Proliferation)

This protocol describes a method to determine the effect of **BRD1652** on the viability and proliferation of a cancer cell line known to be sensitive to BET inhibitors (e.g., MV-4-11, a human acute myeloid leukemia cell line). The CellTiter-Glo® Luminescent Cell Viability Assay is used as an example, which measures ATP levels as an indicator of metabolically active cells.[6]

Materials:

- MV-4-11 cells
- RPMI-1640 medium supplemented with 10% Fetal Bovine Serum (FBS) and 1% Penicillin-Streptomycin
- **BRD1652** stock solution (e.g., 10 mM in DMSO)
- CellTiter-Glo® Luminescent Cell Viability Assay kit
- Opaque-walled 96-well plates suitable for luminescence measurements
- Multimode plate reader with luminescence detection capabilities

Procedure:

- Cell Seeding:
 - Culture MV-4-11 cells to a sufficient density.
 - Harvest and count the cells.
 - Seed the cells in an opaque-walled 96-well plate at a density of 5,000 cells per well in 90 μ L of culture medium.
 - Incubate the plate for 24 hours at 37°C in a humidified atmosphere with 5% CO₂.

- Compound Treatment:
 - Prepare a serial dilution of **BRD1652** in culture medium. A common starting point is a 10-point, 3-fold dilution series starting from 10 μ M.
 - Add 10 μ L of the diluted compound to the respective wells. Include wells with vehicle control (DMSO) and no-cell control (medium only).
 - Incubate the plate for 72 hours at 37°C and 5% CO₂.
- Assay Measurement:
 - Equilibrate the plate and the CellTiter-Glo® reagent to room temperature.
 - Add 100 μ L of CellTiter-Glo® reagent to each well.
 - Mix the contents on an orbital shaker for 2 minutes to induce cell lysis.
 - Incubate the plate at room temperature for 10 minutes to stabilize the luminescent signal.
 - Measure the luminescence using a plate reader.
- Data Analysis:
 - Subtract the background luminescence (no-cell control) from all other readings.
 - Normalize the data to the vehicle control (100% viability).
 - Plot the normalized data against the logarithm of the **BRD1652** concentration and fit a four-parameter logistic curve to determine the IC₅₀ value.

Target Engagement Assay (NanoBRET™)

This protocol measures the direct binding of **BRD1652** to its putative BET target (e.g., BRD4) within living cells using NanoBRET™ technology. This assay relies on Bioluminescence Resonance Energy Transfer (BRET) between a NanoLuc® luciferase-tagged BET protein (the energy donor) and a fluorescently labeled tracer that binds to the same bromodomain (the

energy acceptor). A test compound that binds to the target will compete with the tracer, leading to a decrease in the BRET signal.

Materials:

- HEK293 cells
- Opti-MEM™ I Reduced Serum Medium
- Plasmid DNA encoding the BRD4-NanoLuc® fusion protein
- NanoBRET™ Tracer
- FuGENE® HD Transfection Reagent
- **BRD1652** stock solution
- White, non-binding surface 96-well plates
- NanoBRET™ Nano-Glo® Substrate

Procedure:

- Cell Transfection:
 - Co-transfect HEK293 cells with the BRD4-NanoLuc® plasmid using FuGENE® HD according to the manufacturer's protocol.
 - Plate the transfected cells in a white 96-well plate and incubate for 24 hours.
- Compound and Tracer Addition:
 - Prepare a serial dilution of **BRD1652** in Opti-MEM™.
 - Prepare the NanoBRET™ Tracer at the recommended concentration in Opti-MEM™.
 - Add the diluted **BRD1652** and the tracer to the cells.
 - Incubate at 37°C and 5% CO₂ for 2 hours.

- Signal Detection:
 - Prepare the NanoBRET™ Nano-Glo® Substrate according to the manufacturer's instructions.
 - Add the substrate to each well.
 - Read the plate on a BRET-capable plate reader, measuring both donor (460 nm) and acceptor (618 nm) emission.
- Data Analysis:
 - Calculate the BRET ratio (Acceptor Emission / Donor Emission).
 - Normalize the BRET ratios to the vehicle control.
 - Plot the normalized BRET ratio against the logarithm of the **BRD1652** concentration and fit a dose-response curve to determine the IC50 value for target engagement.

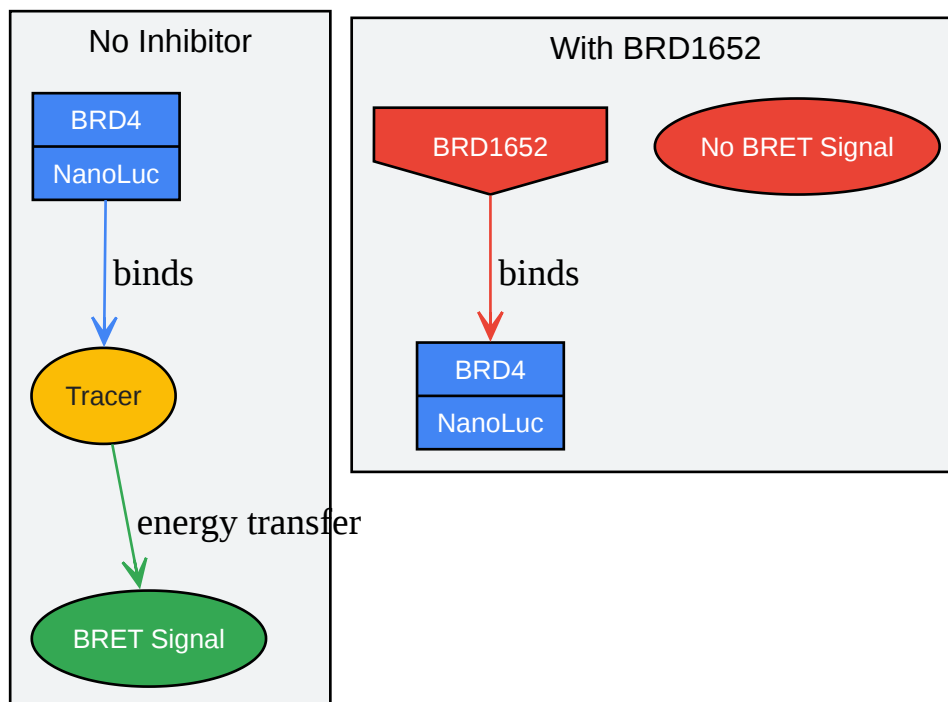

[Click to download full resolution via product page](#)

Need Custom Synthesis?

BenchChem offers custom synthesis for rare earth carbides and specific isotopic labeling.

Email: info@benchchem.com or [Request Quote Online](#).

References

- [1. Intrinsic signaling pathways modulate targeted protein degradation - PMC \[pmc.ncbi.nlm.nih.gov\]](#)
- [2. Bromodomain-Containing Protein 9 Regulates Signaling Pathways and Reprograms the Epigenome in Immortalized Human Uterine Fibroid Cells - PubMed \[pubmed.ncbi.nlm.nih.gov\]](#)
- [3. Bromodomain-Containing Protein 9 Regulates Signaling Pathways and Reprograms the Epigenome in Immortalized Human Uterine Fibroid Cells \[mdpi.com\]](#)
- [4. resources.biomol.com \[resources.biomol.com\]](#)
- [5. criver.com \[criver.com\]](#)
- [6. Cell Based Assays Development_2D Cell-based Assays_Cell-Based Bioassays - 2D Cell-based Assays - ICE Bioscience \[en.ice-biosci.com\]](#)
- To cite this document: BenchChem. [Application Notes and Protocols: Determining the Potency of BRD1652 Using Cell-Based Assays]. BenchChem, [2026]. [Online PDF]. Available at: [<https://www.benchchem.com/product/b12368270/docs#application-notes-and-protocols-determining-the-potency-of-brd1652-using-cell-based-assays>]

Disclaimer & Data Validity:

The information provided in this document is for Research Use Only (RUO) and is strictly not intended for diagnostic or therapeutic procedures. While BenchChem strives to provide accurate protocols, we make no warranties, express or implied, regarding the fitness of this product for every specific experimental setup.

Technical Support: The protocols provided are for reference purposes. Unsure if this reagent suits your experiment?

Need Industrial/Bulk Grade? [Request Custom Synthesis Quote](#)

BenchChem

Our mission is to be the trusted global source of essential and advanced chemicals, empowering scientists and researchers to drive progress in science and industry.

Contact

Address: 3281 E Guasti Rd

Ontario, CA 91761, United States

Phone: (601) 213-4426

Email: info@benchchem.com

[Contact our Ph.D. Support Team for a compatibility check](#)