

A Comparative Guide to Bioanalytical Method Validation for Fexofenadine Following ICH Guidelines

Author: BenchChem Technical Support Team. **Date:** April 2026

Compound of Interest

Compound Name: *Fexofenadine-d3-1*

Cat. No.: *B12368700*

[Get Quote](#)

For Researchers, Scientists, and Drug Development Professionals

This guide provides a comprehensive comparison of validated bioanalytical methods for the quantification of Fexofenadine, a widely used second-generation antihistamine. The validation parameters are presented in accordance with the International Council for Harmonisation (ICH) M10 guideline on bioanalytical method validation, ensuring the reliability and acceptability of the data for regulatory submissions.[1][2][3] This document is intended to assist researchers and analytical scientists in selecting the most appropriate method for their specific needs and in understanding the critical parameters for successful validation.

Experimental Protocols: A Validated RP-HPLC Method

This section details the experimental protocol for a robust and validated Reverse-Phase High-Performance Liquid Chromatography (RP-HPLC) method for the determination of Fexofenadine in pharmaceutical dosage forms.

1. Instrumentation and Chromatographic Conditions:

- HPLC System: A standard HPLC system equipped with a UV-Vis detector is employed.
- Column: A C18 column (e.g., 250 mm x 4.6 mm, 5 μ m particle size) is used for separation.
- Mobile Phase: A mixture of a buffer solution (e.g., 5mM acetate buffer) and an organic solvent (e.g., acetonitrile) in a 50:50 (v/v) ratio is a common mobile phase.[4] The pH of the buffer should be adjusted as needed (e.g., pH 9.4 with acetic acid).[4]
- Flow Rate: A flow rate of 1.0 mL/min is typically maintained.
- Detection Wavelength: The UV detector is set to a wavelength of 220 nm or 254 nm for optimal detection of Fexofenadine.
- Injection Volume: A 20 μ L injection volume is standard.

2. Preparation of Standard and Sample Solutions:

- Standard Stock Solution: A standard stock solution of Fexofenadine hydrochloride is prepared by accurately weighing a known amount of the reference standard and dissolving it in the mobile phase to achieve a specific concentration (e.g., 1 mg/mL).
- Working Standard Solutions: A series of working standard solutions are prepared by diluting the stock solution with the mobile phase to cover the desired concentration range for the calibration curve.
- Sample Preparation: For tablet dosage forms, a representative number of tablets are weighed, crushed into a fine powder, and an amount equivalent to a specific dose of Fexofenadine is dissolved in the mobile phase. The solution is then sonicated and filtered through a 0.45 μ m filter before injection.

3. Method Validation Procedure:

The validation of the analytical method is performed according to ICH guidelines, assessing the following parameters:

- Specificity/Selectivity: The ability of the method to differentiate and quantify the analyte in the presence of other components in the sample matrix is evaluated. This is often assessed by

analyzing blank and placebo samples.

- **Linearity:** The linearity of the method is determined by analyzing a series of at least five concentrations of the analyte. A calibration curve of peak area versus concentration is plotted, and the correlation coefficient (r^2) is calculated. An r^2 value of >0.99 is generally considered acceptable.
- **Accuracy:** The accuracy of the method is determined by recovery studies. Known amounts of the analyte are added to a placebo mixture at different concentration levels (e.g., 80%, 100%, and 120% of the nominal concentration). The percentage recovery is then calculated.
- **Precision:** The precision of the method is evaluated at two levels: repeatability (intra-day precision) and intermediate precision (inter-day precision). Repeatability is assessed by analyzing multiple injections of the same sample on the same day, while intermediate precision is determined by analyzing samples on different days. The results are expressed as the percentage relative standard deviation (%RSD). A %RSD of $<2\%$ is typically required.
- **Limit of Detection (LOD) and Limit of Quantification (LOQ):** The LOD is the lowest concentration of the analyte that can be detected but not necessarily quantified, while the LOQ is the lowest concentration that can be quantified with acceptable precision and accuracy. These are often determined based on the signal-to-noise ratio (typically 3:1 for LOD and 10:1 for LOQ) or from the standard deviation of the response and the slope of the calibration curve.
- **Robustness:** The robustness of the method is evaluated by intentionally varying critical parameters such as the mobile phase composition, flow rate, and column temperature to assess the method's reliability during normal use.

Data Presentation: Comparison of Bioanalytical Methods

The following tables summarize the performance characteristics of different validated analytical methods for Fexofenadine, providing a clear comparison for method selection.

Table 1: Comparison of RP-HPLC Methods for Fexofenadine Analysis

Parameter	Method 1	Method 2	Method 3
Column	C18 (250x4.6 mm, 5 μ m)	Agilent Extend C18	Symmetry C18 (150x4.6mm, 5 μ m)
Mobile Phase	5mM acetate buffer: acetonitrile (50:50)	Acetonitrile: 20 mM KH ₂ PO ₄ (pH 7.5) (35:65)	Buffer: Methanol (30:70)
Flow Rate	1.0 mL/min	1.2 mL/min	1.0 mL/min
Detection	UV at 254 nm	UV at 220 nm	UV at 254 nm
Linearity Range	31.5-500 μ g/mL	10–60 μ g/mL	20-60 μ g/mL
Correlation (r^2)	0.999	> 0.999	> 0.999
Accuracy (% Recovery)	Not Specified	99.45 - 100.52%	Not Specified
Precision (%RSD)	Not Specified	< 2% (Intra-day & Inter-day)	Not Specified
LOD	3.5 μ g/mL	1.50 μ g/mL	3.03 μ g/mL
LOQ	10.1 μ g/mL	4.50 μ g/mL	9.92 μ g/mL

Table 2: Comparison of LC-MS/MS and Other Methods for Fexofenadine Bioanalysis

Parameter	LC-MS/MS Method	UPLC-MS/MS Method	UV-Visible Spectrophotometry
Matrix	Human Plasma	Human Serum	Pharmaceutical Tablets
Linearity Range	0.625–300 ng/mL	1.0–500.0 ng/mL	Not specified
Correlation (r^2)	> 0.99	> 0.99	Not specified
Accuracy (% Recovery)	Within acceptable limits	93% to 98%	Not specified
Precision (%RSD)	Within acceptable limits	±15% (Intra-day & Inter-day)	Not specified
LOD	Not Specified	0.25 ng/mL	Not specified
LOQ	Not Specified	1.0 ng/mL	Not specified

Mandatory Visualizations

The following diagrams illustrate the key workflows and relationships in the bioanalytical method validation process for Fexofenadine.

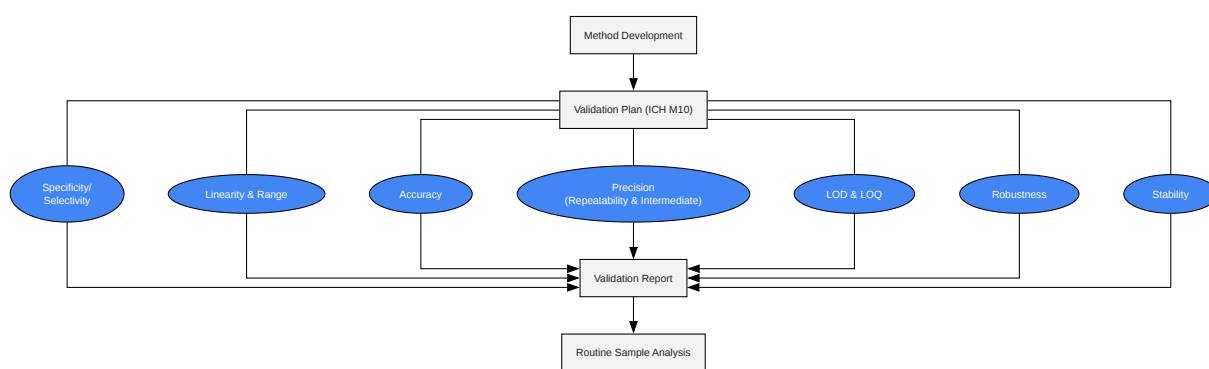

[Click to download full resolution via product page](#)

Caption: Workflow for Bioanalytical Method Validation of Fexofenadine according to ICH M10 Guidelines.

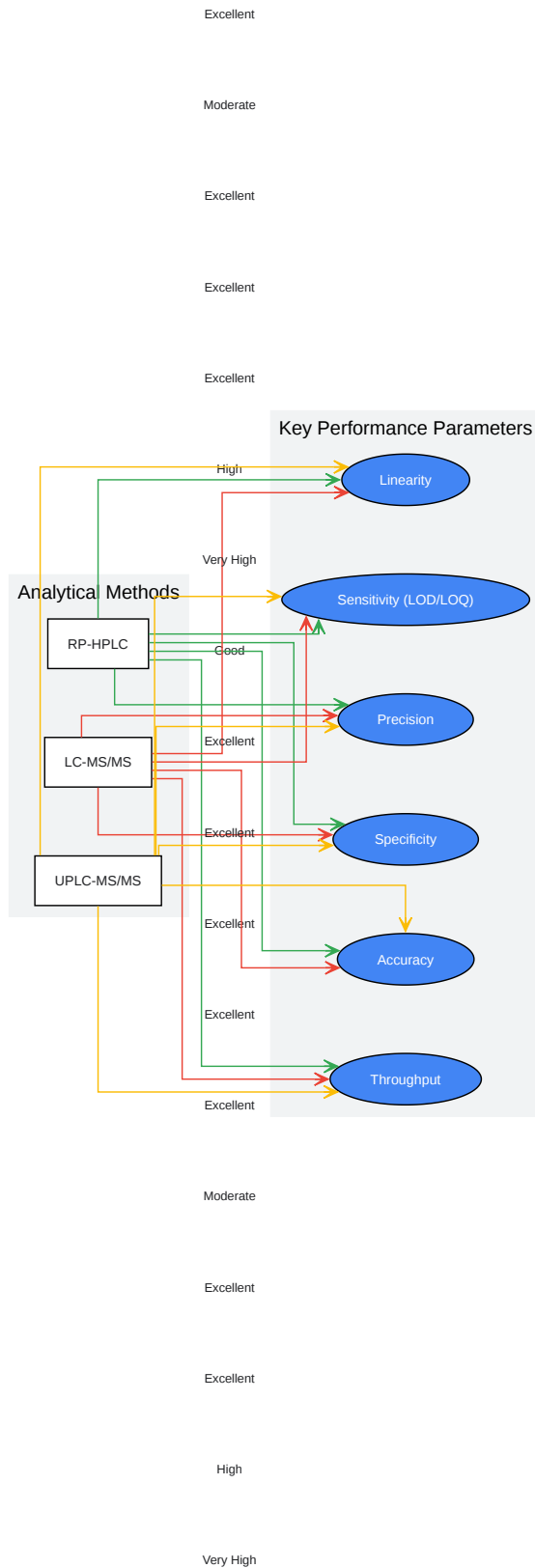

[Click to download full resolution via product page](#)

Caption: Comparison of Key Performance Parameters for Fexofenadine Analytical Methods.

Need Custom Synthesis?

BenchChem offers custom synthesis for rare earth carbides and specific isotopic labeling.

Email: info@benchchem.com or [Request Quote Online](#).

References

- [1. Advanced Analytical Method Validation for Bioequivalence Studies of Fexofenadine in Human Plasma Using LC-MS/MS | Development Engineering Conferences Center Articles Database \[pubs.bcnf.ir\]](#)
- [2. database.ich.org \[database.ich.org\]](#)
- [3. ICH M10 on bioanalytical method validation - Scientific guideline | European Medicines Agency \(EMA\) \[ema.europa.eu\]](#)
- [4. banglajol.info \[banglajol.info\]](#)
- To cite this document: BenchChem. [A Comparative Guide to Bioanalytical Method Validation for Fexofenadine Following ICH Guidelines]. BenchChem, [2026]. [Online PDF]. Available at: [<https://www.benchchem.com/product/b12368700/docs#a-comparative-guide-to-bioanalytical-method-validation-for-fexofenadine-following-ich-guidelines>]

Disclaimer & Data Validity:

The information provided in this document is for Research Use Only (RUO) and is strictly not intended for diagnostic or therapeutic procedures. While BenchChem strives to provide accurate protocols, we make no warranties, express or implied, regarding the fitness of this product for every specific experimental setup.

Technical Support: The protocols provided are for reference purposes. Unsure if this reagent suits your experiment?

Need Industrial/Bulk Grade? [Request Custom Synthesis Quote](#)

BenchChem

Our mission is to be the trusted global source of essential and advanced chemicals, empowering scientists and researchers to drive progress in science and industry.

Contact

Address: 3281 E Guasti Rd

Ontario, CA 91761, United States

Phone: (601) 213-4426

Email: info@benchchem.com

[Contact our Ph.D. Support Team for a compatibility check](#)