

Unveiling the Diuretic Mechanism of BMS-986308: A Comparative Guide

Author: BenchChem Technical Support Team. **Date:** April 2026

Compound of Interest

Compound Name: BMS-986308

Cat. No.: B12367948

[Get Quote](#)

For Researchers, Scientists, and Drug Development Professionals

This guide provides a comprehensive comparison of the novel diuretic agent **BMS-986308** with established diuretic classes. By examining its unique mechanism of action, preclinical and clinical data, we aim to offer valuable insights for researchers and professionals in the field of drug development and renal physiology.

Executive Summary

BMS-986308 is a selective and orally active inhibitor of the renal outer medullary potassium (ROMK) channel, a novel target for diuretic therapy.^{[1][2]} This mechanism contrasts with traditional diuretics, such as loop and thiazide diuretics, which target different ion transporters in the nephron. Preclinical and early clinical data suggest that **BMS-986308** induces potent, potassium-sparing diuresis and natriuresis, offering a promising therapeutic alternative for conditions characterized by fluid overload, such as heart failure.

Comparative Mechanism of Action

Diuretics primarily function by increasing the excretion of sodium (natriuresis) and water (diuresis) from the kidneys. However, the specific tubular transport proteins they inhibit define

their class, efficacy, and side-effect profile.

BMS-986308 (ROMK Inhibitor): **BMS-986308** exerts its diuretic effect by inhibiting the ROMK channel.[1][2] ROMK channels are crucially involved in potassium recycling in the thick ascending limb of the loop of Henle (TALH) and potassium secretion in the cortical collecting duct (CCD).

- In the TALH: Inhibition of ROMK disrupts the function of the Na-K-2Cl cotransporter (NKCC2), the primary site of action for loop diuretics. This leads to a significant increase in sodium and water excretion.
- In the CCD: By blocking ROMK, **BMS-986308** prevents potassium secretion into the urine, resulting in a potassium-sparing effect.

This dual-site action suggests a potentially superior efficacy compared to diuretics that act on a single nephron segment.

Alternative Diuretics:

- Loop Diuretics (e.g., Furosemide): These agents are the most potent diuretics and act by directly inhibiting the NKCC2 cotransporter in the TALH.[3] This leads to a massive excretion of sodium, chloride, and water. However, they also cause significant potassium loss.
- Thiazide Diuretics (e.g., Hydrochlorothiazide): Thiazides inhibit the Na-Cl cotransporter (NCC) in the distal convoluted tubule (DCT), resulting in a moderate increase in sodium and water excretion.[3] Like loop diuretics, they can lead to hypokalemia.
- Potassium-Sparing Diuretics (e.g., Amiloride): These diuretics act on the collecting duct to block the epithelial sodium channel (ENaC), leading to a mild diuresis while conserving potassium.[3]

Signaling Pathway Diagrams

The following diagrams illustrate the distinct mechanisms of action of **BMS-986308** and its comparators on ion transport in the renal tubules.

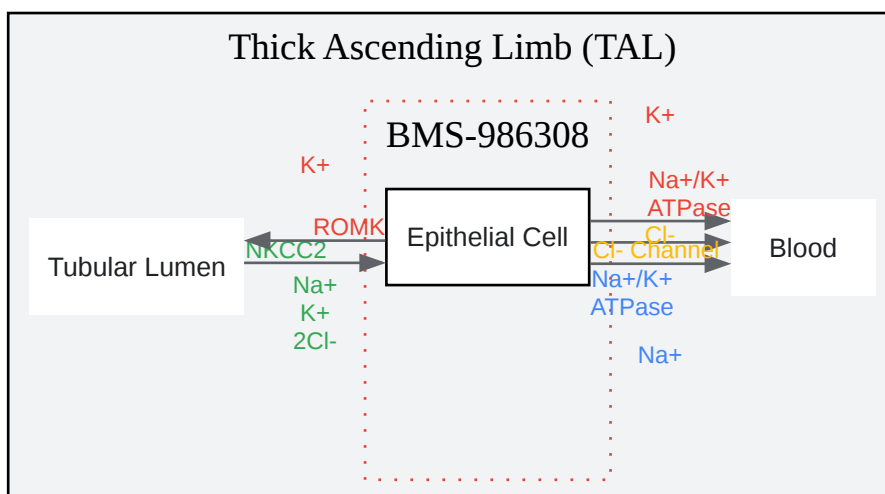

[Click to download full resolution via product page](#)

Mechanism of **BMS-986308** in the TAL

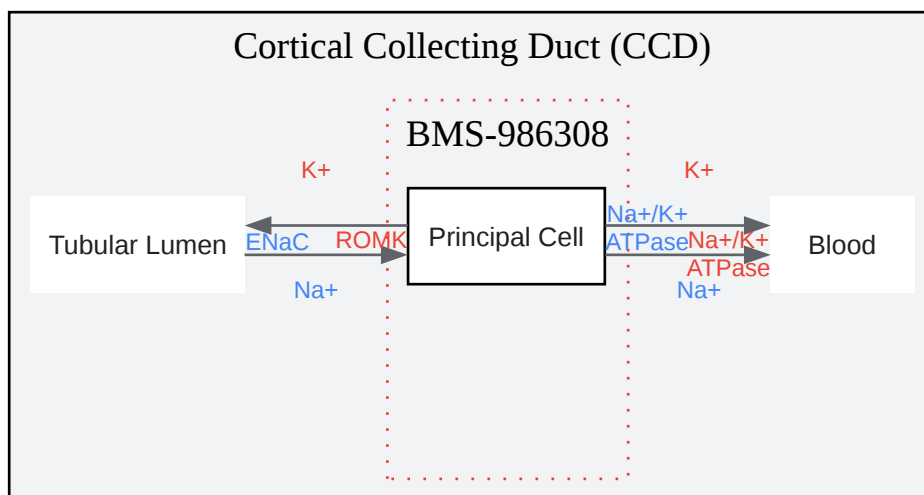

[Click to download full resolution via product page](#)

Mechanism of **BMS-986308** in the CCD

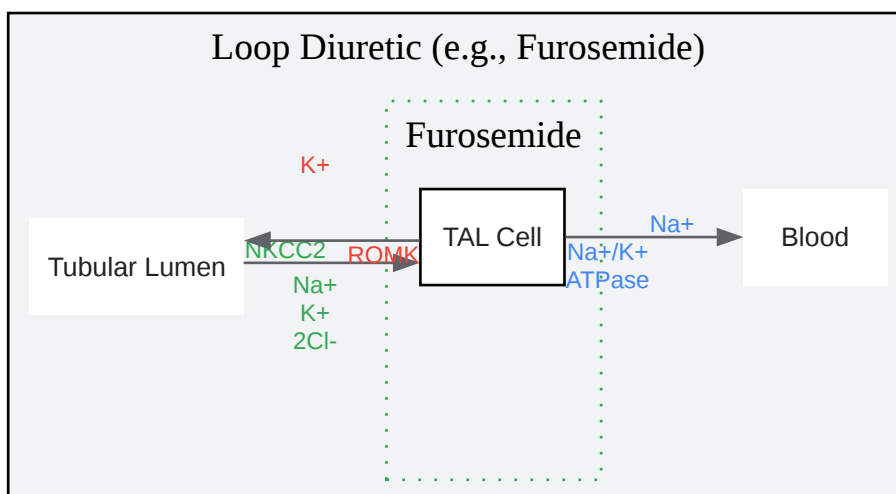

[Click to download full resolution via product page](#)

Mechanism of Loop Diuretics in the TAL

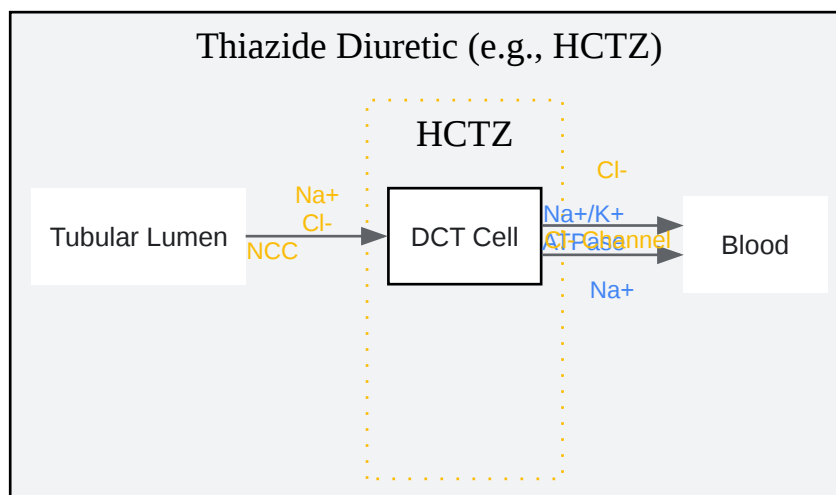

[Click to download full resolution via product page](#)

Mechanism of Thiazide Diuretics in the DCT

Preclinical and Clinical Data

Preclinical Data: Volume-Loaded Rat Model

A study utilizing a volume-loaded rat model provides comparative data for a representative ROMK inhibitor ("compound A") against other diuretic classes. The results demonstrate the

potent diuretic and natriuretic effects of ROMK inhibition, coupled with a significant potassium-sparing advantage.

Table 1: Comparative Diuretic and Natriuretic Effects in a Volume-Loaded Rat Model

Treatment (Dose)	Urine Output (mL/4h)	Urinary Na+ Excretion (mEq/4h)	Urinary K+ Excretion (mEq/4h)
Vehicle	2.5 ± 0.3	0.15 ± 0.02	0.12 ± 0.01
ROMK Inhibitor (compound A, 30 mg/kg)	10.2 ± 0.8	1.2 ± 0.1	0.14 ± 0.02
Bumetanide (10 mg/kg)	12.5 ± 1.1	1.5 ± 0.2	0.35 ± 0.04
Hydrochlorothiazide (10 mg/kg)	8.5 ± 0.7	0.9 ± 0.1	0.28 ± 0.03
Amiloride (3 mg/kg)	4.8 ± 0.5	0.4 ± 0.05	0.08 ± 0.01

Data are presented as mean ± SEM. Data is representative of a study on a ROMK inhibitor and not directly from a **BMS-986308** study.

Clinical Data: First-in-Human Study of BMS-986308

A first-in-human, single-ascending-dose study (NCT04763226) in healthy adult participants demonstrated that **BMS-986308** is safe and well-tolerated.[4] The study also provided evidence of its dose-dependent diuretic and natriuretic effects, with a notable lack of significant increase in potassium excretion.[4]

Table 2: Pharmacodynamic Effects of **BMS-986308** in Healthy Adults (24h post-dose)

Dose	Change from Baseline in Urine Volume (mL)	Change from Baseline in Urinary Na+ (mmol)	Change from Baseline in Urinary K+ (mmol)
Placebo	-	-	-
3 mg	Modest Increase	Modest Increase	No significant change
10 mg	Moderate Increase	Moderate Increase	No significant change
30 mg	Substantial Increase	Substantial Increase	No significant change
100 mg	Robust Increase	Robust Increase	No significant change

Qualitative summary based on reported findings from the NCT04763226 study.[\[4\]](#)

Experimental Protocols

Volume-Loaded Rat Diuresis Model

This preclinical model is designed to assess the diuretic and natriuretic activity of a test compound.

Workflow:

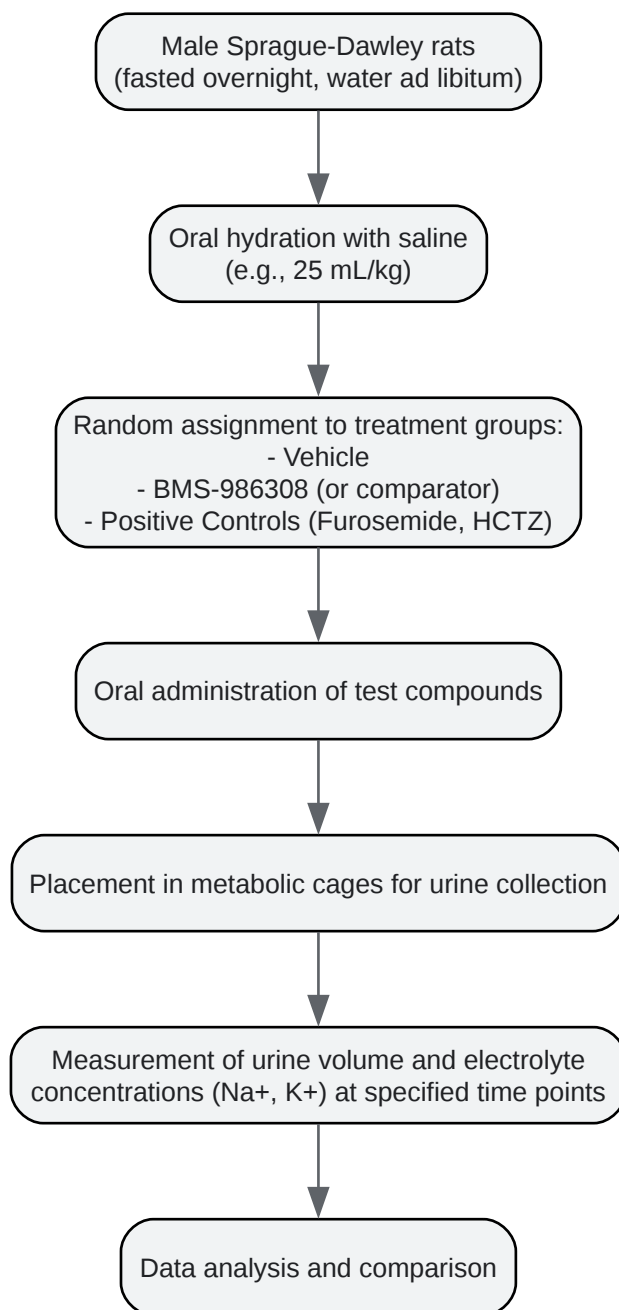

[Click to download full resolution via product page](#)

Experimental workflow for the rat diuresis model.

Methodology:

- Animals: Male Sprague-Dawley rats are typically used. They are fasted overnight with free access to water to ensure a consistent baseline hydration status.

- Hydration: Prior to drug administration, rats are orally hydrated with a saline solution (e.g., 0.9% NaCl at 25 mL/kg body weight) to induce a state of consistent and mild diuresis.
- Drug Administration: Animals are randomly assigned to treatment groups and receive the test compound (**BMS-986308** or comparators) or vehicle control, typically via oral gavage.
- Urine Collection: Immediately after dosing, rats are placed in individual metabolic cages that allow for the separate collection of urine and feces. Urine is collected over a defined period (e.g., 4-8 hours).
- Analysis: The total volume of urine is measured. Urine samples are analyzed for electrolyte concentrations (sodium, potassium, chloride) using methods such as flame photometry or ion-selective electrodes.

First-in-Human Clinical Trial (NCT04763226)

This study was a randomized, double-blind, placebo-controlled, single-ascending-dose trial designed to evaluate the safety, tolerability, pharmacokinetics, and pharmacodynamics of **BMS-986308** in healthy adult participants.

Study Design:

- Participants: Healthy adult volunteers.
- Design: Single-center, randomized, double-blind, placebo-controlled, single-ascending-dose cohorts.
- Intervention: Participants received a single oral dose of **BMS-986308** or a matching placebo.
- Primary Endpoints:
 - Safety and tolerability, assessed by monitoring adverse events, vital signs, electrocardiograms (ECGs), and clinical laboratory tests.
- Secondary Endpoints:
 - Pharmacokinetics of **BMS-986308** (e.g., C_{max}, T_{max}, AUC).

- Pharmacodynamic effects on urine volume and electrolyte excretion (sodium, potassium) over 24 hours.

Conclusion

BMS-986308, through its novel mechanism of ROMK inhibition, presents a promising new approach to diuretic therapy. Its ability to induce significant diuresis and natriuresis while sparing potassium addresses a key limitation of currently available loop and thiazide diuretics. The preclinical and early clinical data support its continued development for the treatment of fluid overload in conditions such as heart failure. Further comparative clinical trials will be essential to fully elucidate its therapeutic potential and position in the clinical landscape.

Need Custom Synthesis?

BenchChem offers custom synthesis for rare earth carbides and specific isotopic labeling.

Email: info@benchchem.com or [Request Quote Online](#).

References

- [1. medchemexpress.com \[medchemexpress.com\]](https://www.medchemexpress.com)
- [2. Discovery of BMS-986308: A Renal Outer Medullary Potassium Channel Inhibitor for the Treatment of Heart Failure - PubMed \[pubmed.ncbi.nlm.nih.gov\]](https://pubmed.ncbi.nlm.nih.gov/)
- [3. news-medical.net \[news-medical.net\]](https://www.news-medical.net)
- [4. ahajournals.org \[ahajournals.org\]](https://www.ahajournals.org)
- To cite this document: BenchChem. [Unveiling the Diuretic Mechanism of BMS-986308: A Comparative Guide]. BenchChem, [2026]. [Online PDF]. Available at: [\[https://www.benchchem.com/product/b12367948/docs#unveiling-the-diuretic-mechanism-of-bms-986308-a-comparative-guide\]](https://www.benchchem.com/product/b12367948/docs#unveiling-the-diuretic-mechanism-of-bms-986308-a-comparative-guide)

Disclaimer & Data Validity:

The information provided in this document is for Research Use Only (RUO) and is strictly not intended for diagnostic or therapeutic procedures. While BenchChem strives to provide

accurate protocols, we make no warranties, express or implied, regarding the fitness of this product for every specific experimental setup.

Technical Support: The protocols provided are for reference purposes. Unsure if this reagent suits your experiment?

Need Industrial/Bulk Grade? [Request Custom Synthesis Quote](#)

BenchChem

Our mission is to be the trusted global source of essential and advanced chemicals, empowering scientists and researchers to drive progress in science and industry.

Contact

Address: 3281 E Guasti Rd

Ontario, CA 91761, United States

Phone: (601) 213-4426

Email: info@benchchem.com

[Contact our Ph.D. Support Team for a compatibility check](#)