

# The Impact of LRRK2-IN-13 on Cellular Signaling: A Technical Guide

**Author:** BenchChem Technical Support Team. **Date:** May 2026

## Compound of Interest

Compound Name: LRRK2-IN-13

Cat. No.: B12367168

[Get Quote](#)

For Researchers, Scientists, and Drug Development Professionals

## Introduction

Leucine-rich repeat kinase 2 (LRRK2) is a large, multi-domain protein that has garnered significant attention in the field of neurodegenerative disease research, particularly for its strong genetic association with Parkinson's disease (PD).<sup>[1][2][3][4]</sup> Mutations in the LRRK2 gene are among the most common causes of both familial and sporadic forms of PD.<sup>[1][3][4]</sup> The LRRK2 protein possesses both kinase and GTPase activity, and pathogenic mutations, such as the common G2019S variant, have been shown to increase its kinase activity, making it a compelling therapeutic target.<sup>[4][5][6]</sup>

**LRRK2-IN-13** is a potent and selective inhibitor of LRRK2 kinase activity. Understanding its effects on cellular pathways is crucial for the development of potential therapeutic interventions for Parkinson's disease and other LRRK2-associated conditions. This technical guide provides an in-depth overview of the cellular pathways affected by **LRRK2-IN-13**, supported by quantitative data, detailed experimental protocols, and pathway visualizations.

## LRRK2-IN-13: Potency and Selectivity

**LRRK2-IN-13** is an ATP-competitive inhibitor that demonstrates high potency against both wild-type (WT) LRRK2 and the pathogenic G2019S mutant. The inhibitory activity of **LRRK2-IN-13** is summarized in the table below.

Target	IC50 (nM)	Assay Type	Reference
LRRK2 (WT)	13	Biochemical	[7]
LRRK2 (G2019S)	6	Biochemical	[5][7][8]

## Core Cellular Pathway Affected: LRRK2-Rab GTPase Signaling

A pivotal breakthrough in understanding LRRK2 function was the identification of a subset of Rab GTPases as key physiological substrates of its kinase activity.[9][10][11] Rab GTPases are master regulators of intracellular vesicular trafficking, a process critical for neuronal function and overall cellular homeostasis.

LRRK2-mediated phosphorylation of Rab proteins occurs on a conserved threonine or serine residue within their switch II domain.[10] This phosphorylation event has significant functional consequences, including:

- **Inhibition of GDI Binding:** Phosphorylated Rabs exhibit a markedly decreased affinity for GDP dissociation inhibitors (GDIs), proteins responsible for maintaining Rab proteins in an inactive, cytosolic state.[9][11]
- **Enhanced Membrane Association:** The loss of GDI binding leads to the accumulation of phosphorylated Rab proteins on cellular membranes.[12]
- **Altered Effector Protein Interaction:** Phosphorylation can modulate the interaction of Rab proteins with their downstream effector molecules, thereby disrupting specific vesicular trafficking pathways.[9]

**LRRK2-IN-13**, by inhibiting the kinase activity of LRRK2, is expected to prevent these phosphorylation-dependent events, thereby rescuing the cellular dysfunctions associated with hyperactive LRRK2.

## Diagram: LRRK2-IN-13 Mechanism of Action

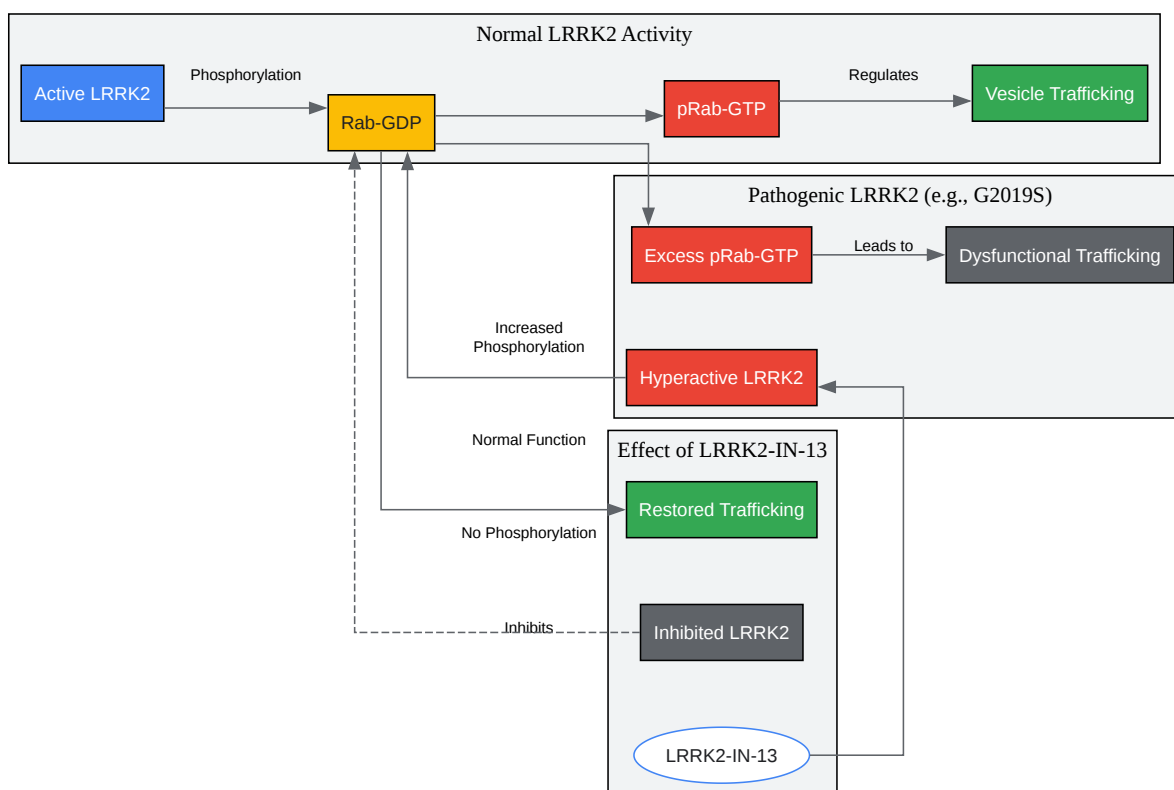

[Click to download full resolution via product page](#)

Caption: Mechanism of **LRRK2-IN-13** in the LRRK2-Rab pathway.

## Other Cellular Processes Potentially Modulated by LRRK2-IN-13

Through its regulation of Rab GTPases and other potential substrates, LRRK2 is implicated in a variety of cellular processes. Inhibition of LRRK2 by **LRRK2-IN-13** is therefore predicted to impact:

- **Autophagy and Lysosomal Function:** LRRK2 has been linked to the regulation of autophagic flux and lysosomal homeostasis.[13] Dysregulation of these processes is a hallmark of many neurodegenerative diseases.
- **Mitochondrial Function:** LRRK2 mutations have been associated with mitochondrial dysfunction, a key factor in the pathogenesis of Parkinson's disease.[13]
- **Ciliogenesis:** Pathogenic LRRK2 mutations can impair the formation and function of primary cilia, cellular organelles involved in signaling and sensory perception.[13]
- **Neuroinflammation:** LRRK2 is expressed in immune cells, including microglia in the brain, and has been implicated in inflammatory responses.[13]

## Key Experimental Protocols

This section provides detailed methodologies for key experiments to assess the cellular effects of **LRRK2-IN-13**.

### In Vitro LRRK2 Kinase Assay

This assay directly measures the ability of **LRRK2-IN-13** to inhibit the kinase activity of purified LRRK2.

Materials:

- Recombinant LRRK2 (WT and/or G2019S mutant)
- Myelin Basic Protein (MBP) as a generic substrate
- **LRRK2-IN-13**

- Kinase Assay Buffer (e.g., 25 mM Tris-HCl pH 7.5, 10 mM MgCl<sub>2</sub>, 2 mM DTT, 0.1 mg/mL BSA)
- [ $\gamma$ -<sup>32</sup>P]ATP
- SDS-PAGE gels and blotting apparatus
- Phosphorimager

#### Procedure:

- Prepare a reaction mixture containing recombinant LRRK2 and varying concentrations of **LRRK2-IN-13** (or DMSO as a vehicle control) in kinase assay buffer.
- Pre-incubate the mixture for 10-15 minutes at 30°C.
- Initiate the kinase reaction by adding a mixture of MBP and [ $\gamma$ -<sup>32</sup>P]ATP.
- Incubate the reaction for 30-60 minutes at 30°C.
- Terminate the reaction by adding SDS-PAGE loading buffer.
- Separate the reaction products by SDS-PAGE.
- Transfer the proteins to a PVDF membrane.
- Expose the membrane to a phosphor screen and quantify the radiolabeled MBP bands using a phosphorimager.
- Calculate the IC<sub>50</sub> value of **LRRK2-IN-13** by plotting the percentage of inhibition against the inhibitor concentration.

## Diagram: In Vitro LRRK2 Kinase Assay Workflow

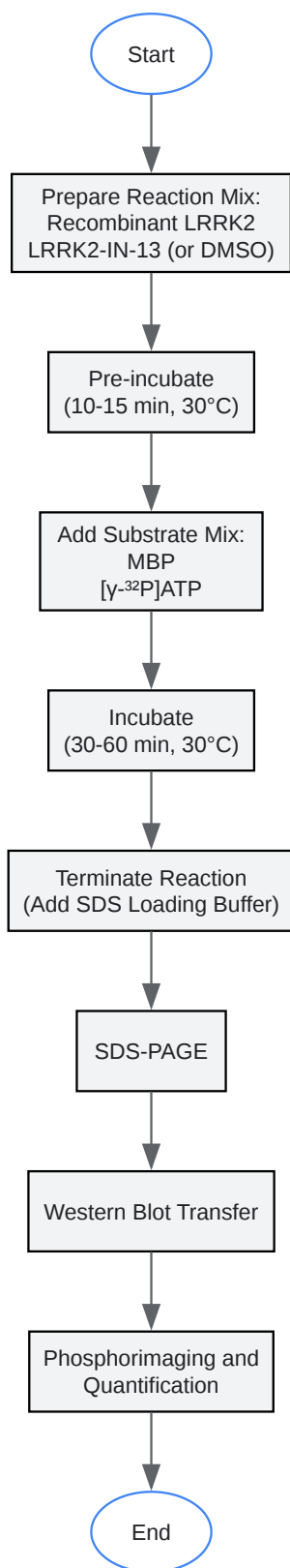

[Click to download full resolution via product page](#)

Caption: Workflow for the in vitro LRRK2 kinase assay.

## Cellular LRRK2 Target Engagement Assay (Immunoblotting of pRab10)

This assay determines the effect of **LRRK2-IN-13** on the phosphorylation of a key LRRK2 substrate, Rab10, in a cellular context.

Materials:

- Cell line expressing endogenous or over-expressed LRRK2 (e.g., A549, HEK293T)
- **LRRK2-IN-13**
- Cell lysis buffer (e.g., RIPA buffer with protease and phosphatase inhibitors)
- BCA protein assay kit
- Primary antibodies: anti-phospho-Rab10 (Thr73), anti-total Rab10, anti-LRRK2, anti-GAPDH (loading control)
- HRP-conjugated secondary antibodies
- Chemiluminescent substrate
- Western blotting equipment and imaging system

Procedure:

- Culture cells to the desired confluency.
- Treat cells with varying concentrations of **LRRK2-IN-13** (or DMSO) for a specified time (e.g., 1-2 hours).
- Wash cells with ice-cold PBS and lyse them in lysis buffer.
- Clarify the lysates by centrifugation and determine the protein concentration using a BCA assay.
- Denature the protein samples by boiling in SDS-PAGE loading buffer.

- Separate equal amounts of protein by SDS-PAGE and transfer to a PVDF membrane.
- Block the membrane with a suitable blocking buffer (e.g., 5% non-fat milk or BSA in TBST).
- Incubate the membrane with primary antibodies overnight at 4°C.
- Wash the membrane and incubate with HRP-conjugated secondary antibodies for 1 hour at room temperature.
- Wash the membrane again and detect the protein bands using a chemiluminescent substrate and an imaging system.
- Quantify the band intensities and normalize the phospho-Rab10 signal to total Rab10 and the loading control.

## Cellular Thermal Shift Assay (CETSA)

CETSA is a powerful method to confirm the direct binding of **LRRK2-IN-13** to LRRK2 in intact cells.[\[14\]](#)[\[15\]](#)[\[16\]](#)

Materials:

- Cell line of interest
- **LRRK2-IN-13**
- PBS
- Cell lysis buffer
- Western blotting equipment

Procedure:

- Treat cultured cells with **LRRK2-IN-13** or vehicle (DMSO).
- Harvest and resuspend the cells in PBS.

- Aliquot the cell suspension into PCR tubes and heat them to a range of temperatures for a set time (e.g., 3 minutes).
- Lyse the cells by freeze-thawing.
- Separate the soluble fraction from the aggregated proteins by centrifugation.
- Analyze the amount of soluble LRRK2 in the supernatant by Western blotting.
- A positive target engagement will result in a thermal stabilization of LRRK2 in the presence of **LRRK2-IN-13**, leading to more soluble protein at higher temperatures compared to the vehicle-treated control.

## Diagram: Cellular Thermal Shift Assay (CETSA) Principle

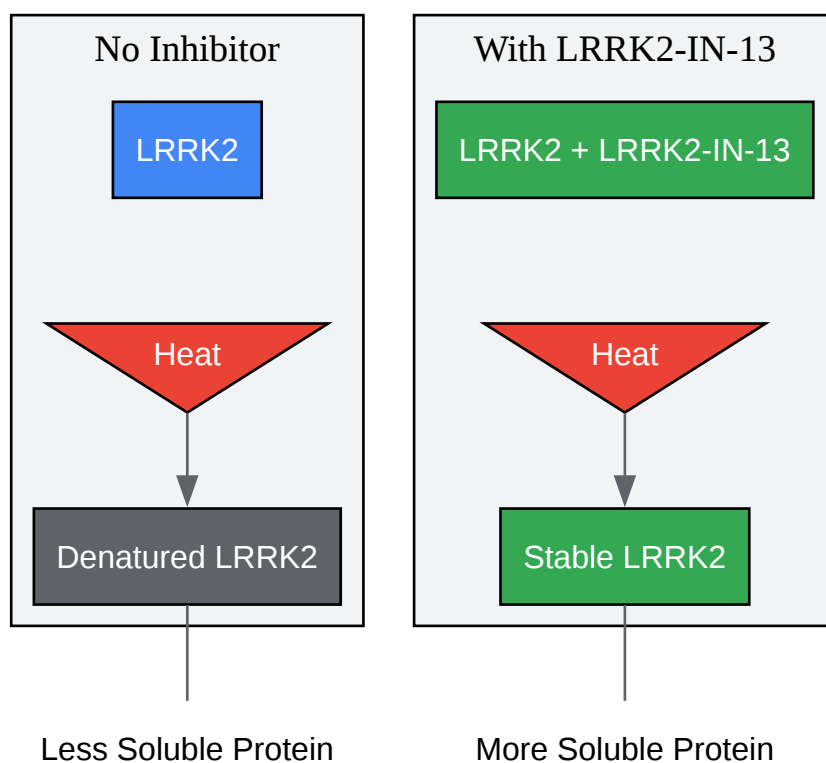

[Click to download full resolution via product page](#)

Caption: Principle of the Cellular Thermal Shift Assay (CETSA).

## Conclusion

**LRRK2-IN-13** is a valuable tool for investigating the cellular functions of LRRK2 and for exploring the therapeutic potential of LRRK2 inhibition. This technical guide provides a foundational understanding of the key cellular pathways affected by this inhibitor, along with detailed protocols for its characterization. By elucidating the precise molecular consequences of LRRK2 inhibition by **LRRK2-IN-13**, researchers can advance the development of novel treatments for Parkinson's disease and other LRRK2-related disorders.

### *Need Custom Synthesis?*

*BenchChem offers custom synthesis for rare earth carbides and specific isotopic labeling.*

*Email: [info@benchchem.com](mailto:info@benchchem.com) or [Request Quote Online](#).*

## References

- [1. LRRK2: Cause, Risk, and Mechanism - PMC \[pmc.ncbi.nlm.nih.gov\]](#)
- [2. Cellular processes associated with LRRK2 function and dysfunction - PMC \[pmc.ncbi.nlm.nih.gov\]](#)
- [3. researchgate.net \[researchgate.net\]](#)
- [4. LRRK2 Structure-Based Activation Mechanism and Pathogenesis \[mdpi.com\]](#)
- [5. Structural Insights and Development of LRRK2 Inhibitors for Parkinson's Disease in the Last Decade - PMC \[pmc.ncbi.nlm.nih.gov\]](#)
- [6. mdpi.com \[mdpi.com\]](#)
- [7. axonmedchem.com \[axonmedchem.com\]](#)
- [8. abmole.com \[abmole.com\]](#)
- [9. portlandpress.com \[portlandpress.com\]](#)
- [10. en-journal.org \[en-journal.org\]](#)
- [11. Phosphoproteomics reveals that Parkinson's disease kinase LRRK2 regulates a subset of Rab GTPases | eLife \[elifesciences.org\]](#)
- [12. LRRK2 phosphorylates membrane-bound Rabs and is activated by GTP-bound Rab7L1 to promote recruitment to the trans-Golgi network - PMC \[pmc.ncbi.nlm.nih.gov\]](#)
- [13. The Multifaceted Role of LRRK2 in Parkinson's Disease - PMC \[pmc.ncbi.nlm.nih.gov\]](#)

- [14. High Throughput Cellular Thermal Shift Assays in Research and Drug Discovery - PMC \[pmc.ncbi.nlm.nih.gov\]](#)
- [15. Real-Time Cellular Thermal Shift Assay to Monitor Target Engagement - PMC \[pmc.ncbi.nlm.nih.gov\]](#)
- [16. biorxiv.org \[biorxiv.org\]](#)
- To cite this document: BenchChem. [The Impact of LRRK2-IN-13 on Cellular Signaling: A Technical Guide]. BenchChem, [2026]. [Online PDF]. Available at: [\[https://www.benchchem.com/product/b12367168/docs#the-impact-of-lrrk2-in-13-on-cellular-signaling-a-technical-guide\]](https://www.benchchem.com/product/b12367168/docs#the-impact-of-lrrk2-in-13-on-cellular-signaling-a-technical-guide)

---

### Disclaimer & Data Validity:

The information provided in this document is for Research Use Only (RUO) and is strictly not intended for diagnostic or therapeutic procedures. While BenchChem strives to provide accurate protocols, we make no warranties, express or implied, regarding the fitness of this product for every specific experimental setup.

**Technical Support:** The protocols provided are for reference purposes. Unsure if this reagent suits your experiment?

**Need Industrial/Bulk Grade?** [Request Custom Synthesis Quote](#)

## BenchChem

Our mission is to be the trusted global source of essential and advanced chemicals, empowering scientists and researchers to drive progress in science and industry.

### Contact

Address: 3281 E Guasti Rd  
Ontario, CA 91761, United States  
Phone: (601) 213-4426  
Email: [info@benchchem.com](mailto:info@benchchem.com)

Contact our Ph.D. Support Team for a compatibility check