

Technical Support Center: Stabilizing MYC Protein During Cell Lysis

Author: BenchChem Technical Support Team. **Date:** April 2026

Compound of Interest

Compound Name: *MYC degrader 1*

Cat. No.: *B12367790*

[Get Quote](#)

This technical support center provides researchers, scientists, and drug development professionals with comprehensive troubleshooting guides and frequently asked questions (FAQs) to prevent the degradation of the highly labile MYC protein during cell lysis and subsequent protein analysis.

Troubleshooting Guide

This guide addresses common issues encountered during the detection of MYC protein, particularly in western blotting experiments.

Question: Why am I observing a weak or no MYC signal on my western blot?

Answer: A weak or absent MYC signal is a frequent challenge due to the protein's inherent instability and rapid turnover. The MYC protein has a very short half-life, typically around 20-30 minutes in non-transformed cells, as it is rapidly targeted for degradation by the ubiquitin-proteasome system.[1] Several factors during cell lysis and sample preparation can contribute to this issue. Here are the potential causes and recommended solutions:

Possible Cause	Recommended Solution
Rapid Protein Degradation	Work quickly and keep samples on ice or at 4°C at all times to minimize enzymatic activity. [2] [3] [4] [5] Use a lysis buffer freshly supplemented with a comprehensive cocktail of protease and phosphatase inhibitors. [3] [6] [7] [8] [9] [10]
Ineffective Lysis Buffer	Use a robust lysis buffer such as RIPA buffer, which is effective for extracting nuclear proteins like MYC. [3] [6] [9] [11] For particularly difficult cases, consider the perchloric acid precipitation method which has been shown to effectively prevent MYC degradation. [12]
Suboptimal Inhibitor Cocktail	Ensure your inhibitor cocktail is broad-spectrum and freshly added to the lysis buffer. [7] [13] [14] For targeted inhibition of MYC's primary degradation pathway, include proteasome inhibitors like MG-132 or lactacystin. [15] [16] [17] [18] [19]
Low Endogenous MYC Levels	Some cell lines have inherently low levels of MYC. [1] Use a positive control cell line known to have high MYC expression (e.g., some leukemia cell lines) to validate your protocol. [20] Increase the amount of total protein loaded onto the gel (typically 20-40 µg, but may need to be higher for low-expression samples). [1]
Inefficient Cell Lysis	Ensure complete cell lysis to release nuclear proteins. Sonication of the lysate on ice can help to shear nuclear DNA and improve the extraction of nuclear proteins. [1] [21] [22]
Multiple Freeze-Thaw Cycles	Aliquot cell lysates after the initial preparation to avoid repeated freeze-thaw cycles, which can lead to protein degradation. [2] Store aliquots at -80°C for long-term storage. [2] [5]

Frequently Asked Questions (FAQs)

Q1: What is the best lysis buffer for preserving MYC protein?

A1: RIPA (Radioimmunoprecipitation Assay) buffer is a commonly recommended and effective choice for lysing cells to detect nuclear proteins like MYC.^{[3][6][9][11]} Its composition of strong detergents helps to efficiently solubilize nuclear and membrane-bound proteins. A typical RIPA buffer formulation is provided in the experimental protocols section. For instances where conventional buffers fail, a perchloric acid precipitation method can be a powerful alternative for preventing MYC degradation.^[12]

Q2: Which inhibitors are essential to include in the lysis buffer for MYC protein analysis?

A2: Due to MYC's rapid degradation via the ubiquitin-proteasome pathway and its regulation by phosphorylation, a combination of protease and phosphatase inhibitors is crucial.

Inhibitor Type	Examples	Recommended Final Concentration	Primary Target(s)
Proteasome Inhibitors	MG-132	10-20 μ M	26S Proteasome
Lactacystin	5-10 μ M	26S Proteasome	
Serine Protease Inhibitors	PMSF	1 mM	Serine proteases
Aprotinin	1-2 μ g/mL	Serine proteases	
Cysteine Protease Inhibitors	Leupeptin	1-2 μ g/mL	Cysteine and serine proteases
Aspartic Protease Inhibitors	Pepstatin A	1 μ g/mL	Aspartic proteases
Phosphatase Inhibitors	Sodium Orthovanadate	1 mM	Tyrosine phosphatases
Sodium Fluoride	10 mM	Serine/threonine phosphatases	
β -glycerophosphate	10 mM	Serine/threonine phosphatases	

Note: It is often convenient to use a commercially available broad-spectrum protease and phosphatase inhibitor cocktail and add it fresh to the lysis buffer just before use.[\[7\]](#)[\[13\]](#)[\[14\]](#)

Q3: What is the typical half-life of MYC protein?

A3: The half-life of MYC protein is notably short, generally between 20 and 30 minutes in untransformed cells.[\[1\]](#)[\[23\]](#) However, this can be significantly longer in certain cancer cells where the degradation pathways are dysregulated. For instance, in some acute lymphoblastic leukemia (ALL) patient samples, the half-life of c-Myc was found to range from 45 to 91 minutes, compared to 17 to 21 minutes in normal bone marrow samples.[\[20\]](#)

Q4: Can I do anything to stabilize MYC in live cells before lysis?

A4: Yes, you can pre-treat your cells with a proteasome inhibitor like MG-132 (10-20 μM) or lactacystin (5-10 μM) for a few hours before harvesting.[15][16][17][18][19] This will block the primary degradation pathway of MYC and lead to its accumulation, making it easier to detect.

Experimental Protocols

Protocol 1: Standard Cell Lysis using RIPA Buffer

This protocol is suitable for the extraction of total cellular proteins, including the nuclear MYC protein.

- Preparation:
 - Pre-chill phosphate-buffered saline (PBS) and RIPA lysis buffer on ice.
 - Immediately before use, supplement the RIPA buffer with a protease and phosphatase inhibitor cocktail to the recommended final concentration.

RIPA Lysis Buffer Composition:

- 50 mM Tris-HCl, pH 7.4
 - 150 mM NaCl
 - 1% NP-40 (or Triton X-100)
 - 0.5% sodium deoxycholate
 - 0.1% SDS
 - 1 mM EDTA
- Cell Harvesting (Adherent Cells):
 - Place the cell culture dish on ice and wash the cells twice with ice-cold PBS.
 - Aspirate the PBS and add an appropriate volume of ice-cold supplemented RIPA buffer (e.g., 100-200 μL for a 6-well plate).

- Scrape the cells from the dish and transfer the lysate to a pre-chilled microcentrifuge tube.
- Cell Harvesting (Suspension Cells):
 - Pellet the cells by centrifugation at 4°C.
 - Wash the cell pellet once with ice-cold PBS and centrifuge again.
 - Resuspend the pellet in an appropriate volume of ice-cold supplemented RIPA buffer.
- Lysis and Clarification:
 - Incubate the lysate on ice for 30 minutes, with occasional vortexing.
 - For enhanced lysis and to shear genomic DNA, sonicate the lysate briefly on ice.
 - Centrifuge the lysate at 14,000 x g for 15 minutes at 4°C to pellet cellular debris.
 - Carefully transfer the supernatant (protein extract) to a new pre-chilled tube.
- Protein Quantification:
 - Determine the protein concentration of the lysate using a standard protein assay (e.g., BCA assay).
 - Normalize the protein concentrations of all samples with lysis buffer to ensure equal loading for subsequent analysis.

Protocol 2: Perchloric Acid Precipitation

This alternative method is highly effective at inactivating proteases and preserving MYC protein.[\[12\]](#)

- Cell Harvesting:
 - Harvest cells as described in the standard protocol (steps 2 or 3).
- Acid Precipitation:

- Add an equal volume of ice-cold 1 M perchloric acid to the cell pellet or lysate with mixing. [\[24\]](#)
- Incubate on ice for 10 minutes.
- Centrifugation and Neutralization:
 - Centrifuge at 1,500 x g for 10 minutes at 4°C.
 - Carefully collect the supernatant and neutralize it to a pH between 7.0 and 8.0 with ice-cold 1 M KOH.[\[24\]](#)
- Final Clarification:
 - Centrifuge at 1,500 x g for 10 minutes at 4°C to pellet the precipitated potassium perchlorate.
 - The resulting supernatant contains the stabilized protein extract.

Visualizations

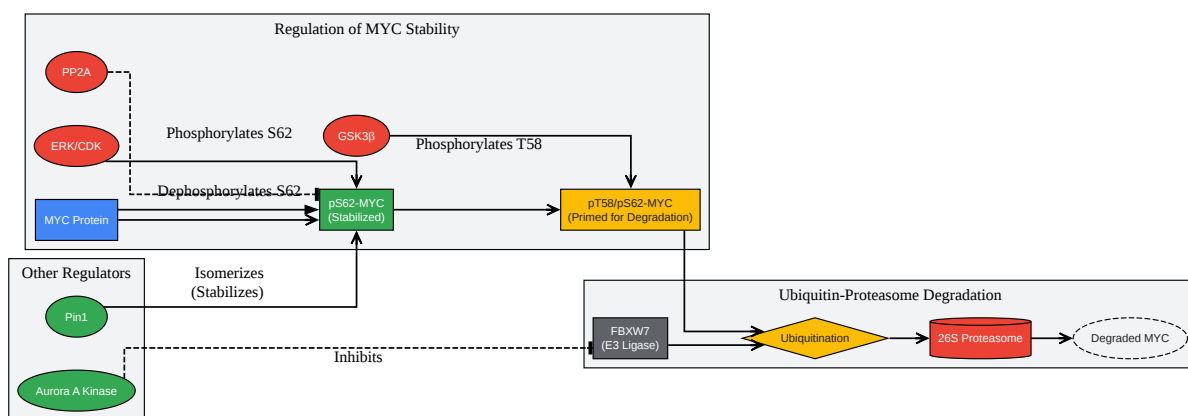

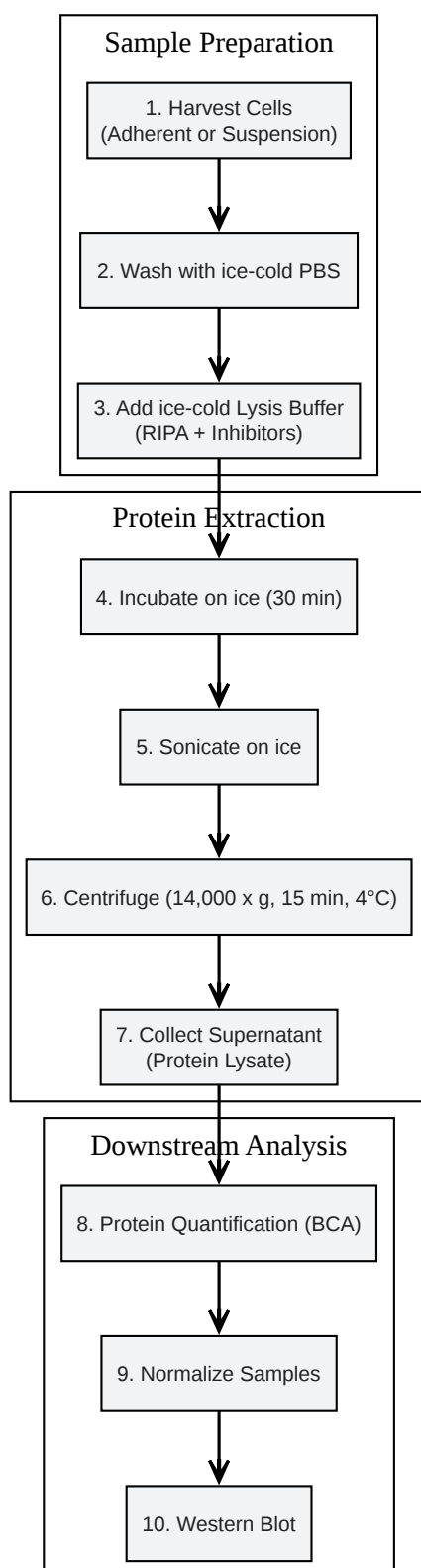

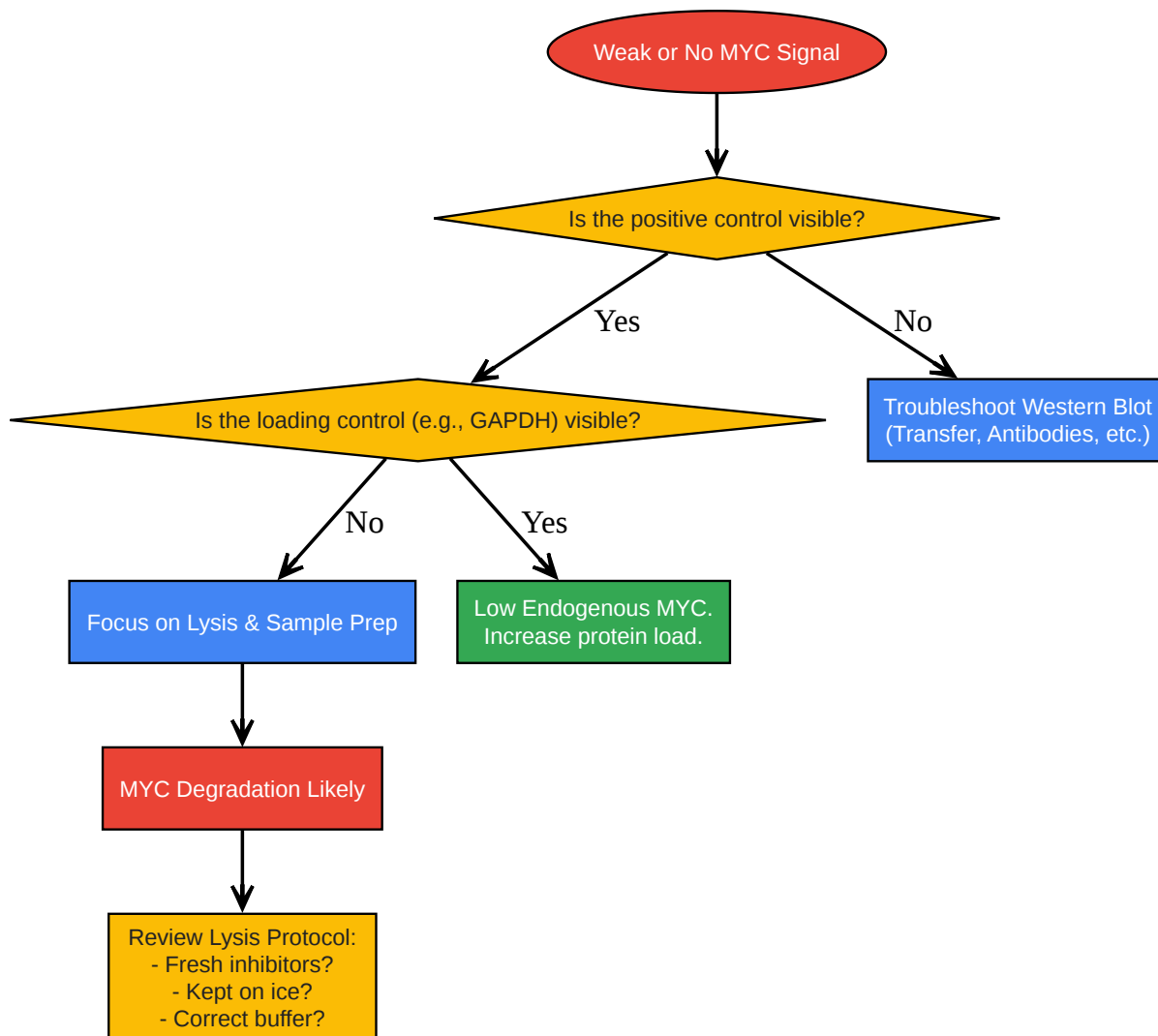

[Click to download full resolution via product page](#)

Need Custom Synthesis?

BenchChem offers custom synthesis for rare earth carbides and specific isotopic labeling.

Email: info@benchchem.com or [Request Quote Online](#).

References

- [1. benchchem.com \[benchchem.com\]](http://1. benchchem.com)

- [2. benchchem.com \[benchchem.com\]](#)
- [3. Choosing The Right Lysis Buffer | Proteintech Group \[ptglab.com\]](#)
- [4. youtube.com \[youtube.com\]](#)
- [5. m.youtube.com \[m.youtube.com\]](#)
- [6. benchchem.com \[benchchem.com\]](#)
- [7. Protease and phosphatase inhibitor cocktails | Abcam \[abcam.com\]](#)
- [8. creative-diagnostics.com \[creative-diagnostics.com\]](#)
- [9. Is Cell Lysis the Next Step After Protein Crosslinking? What Is the Best Lysis Buffer to Use | MtoZ Biolabs \[mtoz-biolabs.com\]](#)
- [10. Western Blot Sample Preparation Protocol | Thermo Fisher Scientific - HK \[thermofisher.com\]](#)
- [11. Cell Lysis Buffers | Thermo Fisher Scientific - TW \[thermofisher.com\]](#)
- [12. Abrogation of c-MYC protein degradation in human lymphocyte lysates by prior precipitation with perchloric acid - PubMed \[pubmed.ncbi.nlm.nih.gov\]](#)
- [13. Protease Phosphatase Inhibitor Cocktail \(100X\) #5872 | Cell Signaling Technology \[cellsignal.com\]](#)
- [14. targetmol.com \[targetmol.com\]](#)
- [15. Proteasome Inhibitors \[labome.com\]](#)
- [16. researchgate.net \[researchgate.net\]](#)
- [17. Combination of Proteasomal Inhibitors Lactacystin and MG132 Induced Synergistic Apoptosis in Prostate Cancer Cells - PMC \[pmc.ncbi.nlm.nih.gov\]](#)
- [18. taylorandfrancis.com \[taylorandfrancis.com\]](#)
- [19. Inhibition of Ubiquitin Proteasome System Rescues the Defective Sarco\(endo\)plasmic Reticulum Ca²⁺-ATPase \(SERCA1\) Protein Causing Chianina Cattle Pseudomyotonia - PMC \[pmc.ncbi.nlm.nih.gov\]](#)
- [20. Aberrant stabilization of c-Myc protein in some lymphoblastic leukemias - PMC \[pmc.ncbi.nlm.nih.gov\]](#)
- [21. origene.com \[origene.com\]](#)
- [22. Protocol: Cell Lysate Preparation for Western Blot: R&D Systems \[rndsystems.com\]](#)
- [23. c-Myc and Cancer Metabolism - PMC \[pmc.ncbi.nlm.nih.gov\]](#)
- [24. prod-media.megazyme.com \[prod-media.megazyme.com\]](#)

- To cite this document: BenchChem. [Technical Support Center: Stabilizing MYC Protein During Cell Lysis]. BenchChem, [2026]. [Online PDF]. Available at: [<https://www.benchchem.com/product/b12367790/docs#technical-support-center-stabilizing-myc-protein-during-cell-lysis>]

Disclaimer & Data Validity:

The information provided in this document is for Research Use Only (RUO) and is strictly not intended for diagnostic or therapeutic procedures. While BenchChem strives to provide accurate protocols, we make no warranties, express or implied, regarding the fitness of this product for every specific experimental setup.

Technical Support: The protocols provided are for reference purposes. Unsure if this reagent suits your experiment?

Need Industrial/Bulk Grade? [Request Custom Synthesis Quote](#)

BenchChem

Our mission is to be the trusted global source of essential and advanced chemicals, empowering scientists and researchers to drive progress in science and industry.

Contact

Address: 3281 E Guasti Rd
Ontario, CA 91761, United States
Phone: (601) 213-4426
Email: info@benchchem.com

[Contact our Ph.D. Support Team for a compatibility check](#)