

# Technical Support Center: Optimizing HC-1310 Concentration for In Vitro Assays

**Author:** BenchChem Technical Support Team. **Date:** April 2026

## Compound of Interest

Compound Name: HC-1310  
Cat. No.: B12367122

[Get Quote](#)

Welcome to the technical support center for **HC-1310**, a potent and selective inhibitor of the PI3K/Akt/mTOR signaling pathway. This resource is designed to assist researchers, scientists, and drug development professionals in optimizing the concentration of **HC-1310** for your in vitro assays. Here you will find troubleshooting guides and frequently asked questions (FAQs) to address common issues encountered during experimentation.

## Frequently Asked Questions (FAQs)

Q1: What is the recommended starting concentration range for **HC-1310** in cell-based assays?

A1: For initial experiments, we recommend a broad concentration range to determine the optimal dose for your specific cell line and assay. A typical starting range is from 0.1  $\mu\text{M}$  to 10  $\mu\text{M}$ .<sup>[1][2]</sup> It is crucial to perform a dose-response curve to identify the half-maximal inhibitory concentration (IC50) in your experimental system.

Q2: How should I prepare the stock solution for **HC-1310**?

A2: We recommend preparing a high-concentration stock solution of 10 mM in a high-quality, anhydrous solvent such as DMSO.<sup>[3]</sup> Store the stock solution in small aliquots at  $-20^{\circ}\text{C}$  or  $-80^{\circ}\text{C}$  to avoid repeated freeze-thaw cycles, which can lead to compound degradation.<sup>[4][5]</sup>

When preparing working solutions, dilute the stock in your cell culture medium immediately before use.

Q3: I am observing low potency of **HC-1310** in my cell-based assay compared to the reported biochemical IC50. What could be the reason?

A3: Discrepancies between biochemical and cell-based assay potencies are common. Several factors can contribute to this:

- Cell Permeability: The compound may have limited ability to cross the cell membrane, resulting in a lower intracellular concentration.[6]
- Protein Binding: **HC-1310** may bind to proteins in the cell culture serum, reducing its free and active concentration.[7]
- Efflux Pumps: Cells can actively transport the inhibitor out of the cell using efflux pumps like P-glycoprotein.[6]
- Inhibitor Stability: The compound may be metabolized by the cells or be unstable in the cell culture medium over the course of the experiment.[3][6]

Q4: How can I confirm that **HC-1310** is inhibiting the PI3K/Akt/mTOR pathway in my cells?

A4: To confirm on-target activity, you should perform a western blot analysis to examine the phosphorylation status of key downstream effectors of the pathway. A decrease in the phosphorylation of Akt (at Ser473 and Thr308) and S6 ribosomal protein (at Ser235/236) upon treatment with **HC-1310** would indicate successful target engagement.[8]

Q5: What are the potential off-target effects of **HC-1310**?

A5: While **HC-1310** is designed to be a selective inhibitor, off-target effects can occur, especially at higher concentrations.[9][10] These can arise from the structural similarity of the ATP-binding pocket across different kinases.[10] To mitigate off-target effects, it is crucial to use the lowest effective concentration that inhibits the primary target and to validate findings with a structurally unrelated inhibitor of the same pathway.[6][10]

## Troubleshooting Guides

Issue 1: **HC-1310** precipitates in the cell culture medium.

- Possible Cause: The concentration of **HC-1310** exceeds its solubility limit in the aqueous environment of the cell culture medium.[11]
- Troubleshooting Steps:
  - Visual Inspection: Carefully examine the culture wells under a microscope for any signs of precipitation after adding the inhibitor.
  - Lower the Final Concentration: Perform a dose-response experiment to determine if a lower concentration is still effective.
  - Optimize Solvent Concentration: Ensure the final concentration of the solvent (e.g., DMSO) is kept low, typically below 0.5%, and ideally below 0.1%, as high solvent concentrations can also cause precipitation and toxicity.[5][6]
  - Serum Concentration: Test the effect of different serum concentrations in your media, as serum proteins can sometimes influence compound solubility.[11]

Issue 2: Inconsistent or non-reproducible results between experiments.

- Possible Cause: This can be due to several factors including inhibitor instability, improper storage, or variability in experimental procedures.
- Troubleshooting Steps:
  - Inhibitor Stability: Prepare fresh dilutions of **HC-1310** from a frozen stock for each experiment. Avoid storing the inhibitor in cell culture medium for extended periods.[5] You can assess the stability of **HC-1310** in your specific medium by incubating it for different durations and then testing its activity.[6]
  - Storage: Ensure that the stock solution is stored correctly at -20°C or -80°C in tightly sealed vials to prevent degradation.[4][5]
  - Consistent Protocols: Maintain consistency in all experimental steps, including cell seeding density, treatment duration, and assay procedures.

Issue 3: High levels of cell death observed even at low concentrations of **HC-1310**.

- Possible Cause: The observed cytotoxicity may be due to on-target inhibition of a critical survival pathway in your specific cell line or potent off-target effects.[\[5\]](#)[\[10\]](#)
- Troubleshooting Steps:
  - Dose-Response and Time-Course: Perform a detailed dose-response and time-course experiment to identify a non-toxic concentration and a suitable treatment duration.
  - Apoptosis Assays: Use assays such as Annexin V staining or caspase activity assays to determine if the cell death is due to apoptosis.[\[10\]](#)
  - Rescue Experiments: If possible, perform rescue experiments by overexpressing a downstream effector to confirm that the cytotoxicity is due to on-target pathway inhibition.

## Quantitative Data Summary

The following table summarizes typical concentration ranges for small molecule inhibitors like **HC-1310** in various in vitro assays. Note that these are general guidelines, and the optimal concentration should be determined empirically for your specific experimental conditions.

Assay Type	Typical Concentration Range	Key Considerations
Cell Viability (e.g., MTT, CellTiter-Glo)	0.01 $\mu$ M - 100 $\mu$ M	Perform a full dose-response curve to determine IC50.[12] [13]
Western Blotting	0.1 $\mu$ M - 10 $\mu$ M	Use a concentration that shows clear inhibition of target phosphorylation without causing excessive cell death. [8]
Enzyme Inhibition Assay (Biochemical)	1 nM - 10 $\mu$ M	IC50 values are typically lower than in cell-based assays due to the absence of cellular barriers.[1]
Immunofluorescence	0.1 $\mu$ M - 5 $\mu$ M	Titrate to find a concentration that shows a clear effect on protein localization or expression without altering cell morphology.

## Experimental Protocols

### Protocol 1: Determination of IC50 using CellTiter-Glo® Luminescent Cell Viability Assay

This protocol outlines the steps to determine the half-maximal inhibitory concentration (IC50) of **HC-1310**.

- **Cell Seeding:** Seed your cells in an opaque-walled 96-well plate at a predetermined optimal density (e.g., 5,000-10,000 cells/well) in 100  $\mu$ L of complete culture medium. Include wells with medium only for background control.
- **Incubation:** Incubate the plate overnight at 37°C in a humidified atmosphere with 5% CO2 to allow the cells to attach.

- **Compound Treatment:** Prepare a serial dilution of **HC-1310** in complete culture medium. A common starting range is from 100  $\mu\text{M}$  down to 0.01  $\mu\text{M}$ . Add the diluted compound to the respective wells. Include a vehicle control (e.g., DMSO) at the same final concentration as in the highest **HC-1310** concentration wells.
- **Incubation:** Incubate the plate for the desired treatment duration (e.g., 24, 48, or 72 hours).
- **Assay Procedure:**
  - Equilibrate the plate and the CellTiter-Glo® reagent to room temperature for approximately 30 minutes.[\[14\]](#)
  - Add a volume of CellTiter-Glo® Reagent equal to the volume of cell culture medium in each well (e.g., 100  $\mu\text{L}$ ).[\[14\]](#)
  - Mix the contents for 2 minutes on an orbital shaker to induce cell lysis.[\[14\]](#)
  - Allow the plate to incubate at room temperature for 10 minutes to stabilize the luminescent signal.[\[14\]](#)
- **Data Acquisition:** Record the luminescence using a luminometer.
- **Data Analysis:**
  - Subtract the average background luminescence from all other readings.
  - Normalize the data by expressing the luminescence of treated wells as a percentage of the vehicle control.
  - Plot the percentage of cell viability versus the log of the inhibitor concentration and fit the data using a non-linear regression model (e.g., four-parameter logistic curve) to determine the IC50 value.[\[15\]](#)

## Protocol 2: Western Blot Analysis of PI3K/Akt/mTOR Pathway Inhibition

This protocol describes how to verify the on-target effects of **HC-1310** by examining the phosphorylation of downstream proteins.

- Cell Treatment: Seed cells in a 6-well plate and grow them to 70-80% confluency. Treat the cells with various concentrations of **HC-1310** (and a vehicle control) for a predetermined time (e.g., 2-24 hours).
- Cell Lysis:
  - After treatment, wash the cells twice with ice-cold phosphate-buffered saline (PBS).
  - Add an appropriate volume of ice-cold lysis buffer (e.g., RIPA buffer) supplemented with protease and phosphatase inhibitors.[16][17]
  - Scrape the cells and transfer the lysate to a microcentrifuge tube.
  - Incubate on ice for 30 minutes with periodic vortexing.
  - Centrifuge at 14,000 x g for 15 minutes at 4°C to pellet the cell debris.
  - Transfer the supernatant to a new tube.
- Protein Quantification: Determine the protein concentration of each sample using a protein assay such as the BCA assay.
- Sample Preparation:
  - Normalize the protein concentration of all samples with lysis buffer.
  - Add Laemmli sample buffer to a final concentration of 1x and heat the samples at 95-100°C for 5 minutes.[16]
- SDS-PAGE and Transfer:
  - Load equal amounts of protein (e.g., 20-30 µg) onto a polyacrylamide gel and separate the proteins by electrophoresis.
  - Transfer the separated proteins to a nitrocellulose or PVDF membrane.

- Immunoblotting:
  - Block the membrane with a suitable blocking buffer (e.g., 5% non-fat dry milk or BSA in TBST) for 1 hour at room temperature.[18]
  - Incubate the membrane with primary antibodies against phospho-Akt (Ser473), total Akt, phospho-S6 (Ser235/236), total S6, and a loading control (e.g.,  $\beta$ -actin or GAPDH) overnight at 4°C.
  - Wash the membrane three times with TBST.
  - Incubate with the appropriate HRP-conjugated secondary antibody for 1 hour at room temperature.
  - Wash the membrane again three times with TBST.
- Detection: Detect the protein bands using an enhanced chemiluminescence (ECL) substrate and an imaging system.
- Analysis: Quantify the band intensities and normalize the phosphorylated protein levels to the total protein levels to determine the extent of pathway inhibition.

## Visualizations

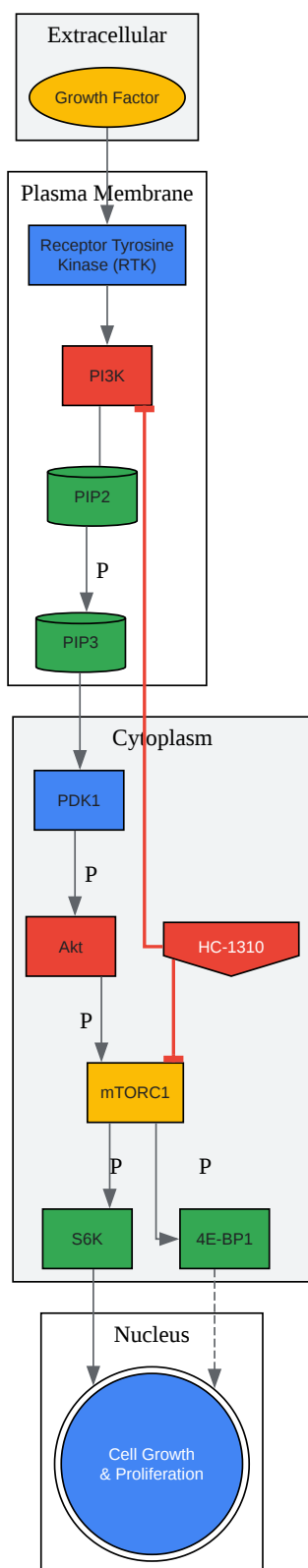

[Click to download full resolution via product page](#)

Caption: The PI3K/Akt/mTOR signaling pathway and the inhibitory action of **HC-1310**.

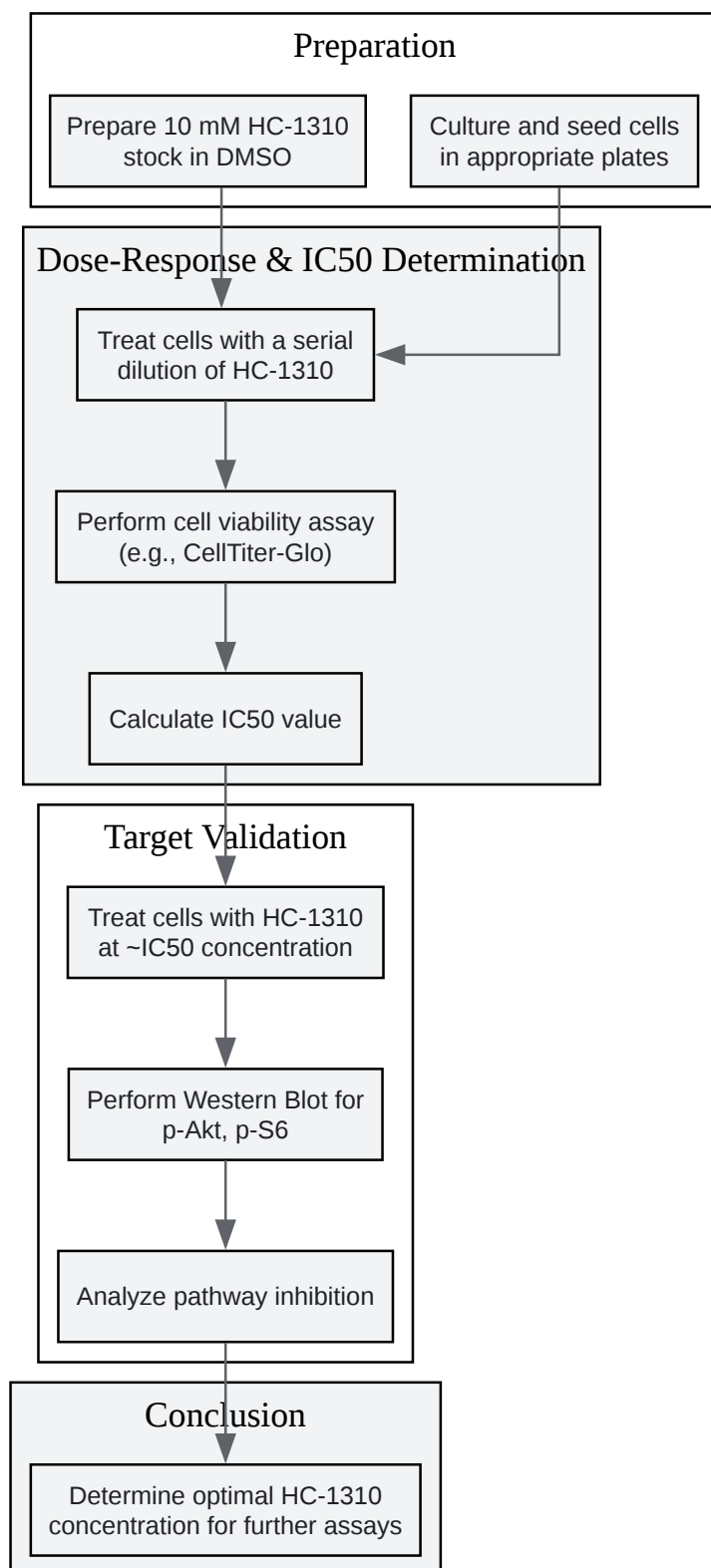

[Click to download full resolution via product page](#)

### Need Custom Synthesis?

BenchChem offers custom synthesis for rare earth carbides and specific isotopic labeling.

Email: [info@benchchem.com](mailto:info@benchchem.com) or [Request Quote Online](#).

## References

- [1. resources.biomol.com](https://resources.biomol.com) [[resources.biomol.com](https://resources.biomol.com)]
- [2. caymanchem.com](https://caymanchem.com) [[caymanchem.com](https://caymanchem.com)]
- [3. benchchem.com](https://benchchem.com) [[benchchem.com](https://benchchem.com)]
- [4. benchchem.com](https://benchchem.com) [[benchchem.com](https://benchchem.com)]
- [5. benchchem.com](https://benchchem.com) [[benchchem.com](https://benchchem.com)]
- [6. benchchem.com](https://benchchem.com) [[benchchem.com](https://benchchem.com)]
- [7. pubs.acs.org](https://pubs.acs.org) [[pubs.acs.org](https://pubs.acs.org)]
- [8. researchgate.net](https://researchgate.net) [[researchgate.net](https://researchgate.net)]
- [9. Kinase inhibitors can produce off-target effects and activate linked pathways by retroactivity - PMC](#) [[pmc.ncbi.nlm.nih.gov](https://pmc.ncbi.nlm.nih.gov)]
- [10. benchchem.com](https://benchchem.com) [[benchchem.com](https://benchchem.com)]
- [11. benchchem.com](https://benchchem.com) [[benchchem.com](https://benchchem.com)]
- [12. Protocol for Determining the IC50 of Drugs on Adherent Cells Using MTT Assay - Creative Bioarray | Creative Bioarray](#) [[creative-bioarray.com](https://creative-bioarray.com)]
- [13. benchchem.com](https://benchchem.com) [[benchchem.com](https://benchchem.com)]
- [14. scribd.com](https://scribd.com) [[scribd.com](https://scribd.com)]
- [15. benchchem.com](https://benchchem.com) [[benchchem.com](https://benchchem.com)]
- [16. benchchem.com](https://benchchem.com) [[benchchem.com](https://benchchem.com)]
- [17. Western Blot Sample Preparation Protocol | Thermo Fisher Scientific - KR](#) [[thermofisher.com](https://thermofisher.com)]
- [18. Western Blot Procedure | Cell Signaling Technology](#) [[cellsignal.com](https://cellsignal.com)]
- To cite this document: BenchChem. [Technical Support Center: Optimizing HC-1310 Concentration for In Vitro Assays]. BenchChem, [2026]. [Online PDF]. Available at:

[\[https://www.benchchem.com/product/b12367122/docs#technical-support-center-optimizing-hc-1310-concentration-for-in-vitro-assays\]](https://www.benchchem.com/product/b12367122/docs#technical-support-center-optimizing-hc-1310-concentration-for-in-vitro-assays)

### Disclaimer & Data Validity:

The information provided in this document is for Research Use Only (RUO) and is strictly not intended for diagnostic or therapeutic procedures. While BenchChem strives to provide accurate protocols, we make no warranties, express or implied, regarding the fitness of this product for every specific experimental setup.

**Technical Support:** The protocols provided are for reference purposes. Unsure if this reagent suits your experiment?

**Need Industrial/Bulk Grade?** [Request Custom Synthesis Quote](#)

## BenchChem

Our mission is to be the trusted global source of essential and advanced chemicals, empowering scientists and researchers to drive progress in science and industry.

### Contact

Address: 3281 E Guasti Rd  
Ontario, CA 91761, United States  
Phone: (601) 213-4426  
Email: [info@benchchem.com](mailto:info@benchchem.com)

[Contact our Ph.D. Support Team for a compatibility check](#)