

# Technical Support Center: MYC Western Blot Analysis

**Author:** BenchChem Technical Support Team. **Date:** April 2026

## Compound of Interest

Compound Name: MYC degrader 1

Cat. No.: B12367790

[Get Quote](#)

This technical support center provides troubleshooting guides and frequently asked questions (FAQs) to assist researchers, scientists, and drug development professionals in performing successful MYC Western blot analysis.

## Frequently Asked Questions (FAQs)

Q1: What are the best loading controls for MYC Western blot analysis?

A1: Selecting an appropriate loading control is critical for accurate normalization of MYC protein levels. Common choices include housekeeping proteins, but their expression can be influenced by experimental conditions.

- **Traditional Housekeeping Proteins:** GAPDH,  $\beta$ -actin, and  $\alpha$ -tubulin are frequently used as loading controls due to their typically high and stable expression.[1][2] However, it is crucial to validate their expression stability in your specific experimental model, as factors like cell density and disease state can alter their levels.[3][4]
- **Nuclear-Specific Loading Controls:** Since MYC is a nuclear protein, using a nuclear-specific loading control like Lamin B1 or Histone H3 can be more appropriate, especially when analyzing nuclear fractions.[5]

- **Total Protein Normalization:** An increasingly popular and often more reliable alternative is total protein normalization.[6] This can be achieved by staining the membrane with Ponceau S or using stain-free gel technology.[4] This method accounts for inconsistencies in protein loading and transfer without relying on the expression of a single protein.

Q2: Why is my MYC signal weak or absent?

A2: A weak or non-existent MYC signal is a common issue, often attributable to the protein's inherent instability.

- **Short Protein Half-Life:** The MYC protein has a very short half-life, typically around 20-30 minutes, as it is rapidly targeted for degradation.[7][8]
- **Sample Preparation:** To prevent degradation, it is crucial to work quickly, keep samples on ice, and use lysis buffers supplemented with fresh protease and phosphatase inhibitors.[7][8]
- **Low Endogenous Expression:** Endogenous MYC levels can be low in some cell lines.[9] Consider using a positive control, such as a cell line known to overexpress MYC, to validate your antibody and protocol. For very low expression, immunoprecipitation (IP) prior to Western blotting may be necessary to enrich the MYC protein.[9]
- **Antibody Selection:** Ensure you are using a highly specific monoclonal antibody validated for detecting endogenous MYC.[7] Some antibodies, like the 9E10 clone, are excellent for detecting the Myc-tag but may not be suitable for endogenous mouse c-Myc.[9]

Q3: Why do I see high background on my MYC Western blot?

A3: High background can obscure your MYC signal and make data interpretation difficult. Several factors can contribute to this issue.

- **Inadequate Blocking:** Insufficient blocking of the membrane can lead to non-specific antibody binding.[7][10] Try increasing the blocking time or using a different blocking agent (e.g., 5% non-fat dry milk or BSA in TBST).[1][11]
- **Antibody Concentration:** The concentration of both the primary and secondary antibodies may be too high.[7][10] It is important to titrate your antibodies to find the optimal concentration that provides a strong signal with low background.

- **Insufficient Washing:** Inadequate washing between antibody incubations can result in high background.<sup>[7][11]</sup> Increase the number and duration of washes to effectively remove unbound antibodies.
- **Membrane Handling:** Ensure the membrane does not dry out at any point during the procedure, as this can cause non-specific antibody binding.<sup>[7][12]</sup>

## Troubleshooting Guide

This guide provides a structured approach to resolving common issues encountered during MYC Western blot analysis.

### Problem: Weak or No MYC Signal

Possible Cause	Recommended Solution
MYC Protein Degradation	Work quickly during sample preparation and keep samples on ice. Use a lysis buffer containing a fresh cocktail of protease and phosphatase inhibitors. <sup>[7]</sup>
Low Protein Expression	Use a positive control cell line with known high MYC expression. Consider immunoprecipitation to enrich for MYC protein before blotting. <sup>[9]</sup> Increase the amount of protein loaded onto the gel (e.g., 40 µg of total protein per lane).
Inefficient Protein Transfer	Verify transfer efficiency by staining the membrane with Ponceau S after transfer. Ensure good contact between the gel and the membrane and that the transfer was run under appropriate conditions.
Suboptimal Antibody Concentration	Optimize the primary antibody concentration. A higher concentration might be needed for detecting low-abundance proteins.
Incorrect Antibody Selection	Use a primary antibody specifically validated for detecting endogenous MYC in your species of interest. <sup>[9]</sup>

## Problem: High Background

Possible Cause	Recommended Solution
Inadequate Blocking	Increase blocking time to at least 1 hour at room temperature or overnight at 4°C. Try switching between 5% non-fat dry milk and 5% BSA in TBST.[1][7][11]
Antibody Concentration Too High	Titrate the primary and secondary antibodies to determine the optimal dilution that maximizes signal-to-noise ratio.[7][10]
Insufficient Washing	Increase the number and duration of washes with TBST after primary and secondary antibody incubations (e.g., three washes of 10-15 minutes each).[7][11]
Membrane Drying Out	Ensure the membrane remains hydrated throughout the entire Western blotting process.[7][12]
Non-specific Secondary Antibody Binding	Run a control lane with only the secondary antibody to check for non-specific binding.[10]

## Problem: Inconsistent Results

Possible Cause	Recommended Solution
Variable Protein Loading	Accurately quantify protein concentration using an assay like BCA or Bradford.[1] Use a reliable loading control for normalization.
Inconsistent Sample Preparation	Standardize the cell lysis and sample handling procedures to minimize variability due to the short half-life of MYC.[7]
Variations in Cell Culture	Ensure cells are seeded at the same density and are in the same growth phase (e.g., logarithmic phase) before treatment and harvesting.[7]

## Experimental Protocols

### Detailed Western Blot Protocol for MYC Analysis

- Sample Preparation:
  - Wash cells with ice-cold PBS.
  - Lyse cells in ice-cold RIPA buffer (50 mM Tris-HCl pH 7.4, 150 mM NaCl, 1% NP-40, 0.5% sodium deoxycholate, 0.1% SDS) supplemented with a fresh protease and phosphatase inhibitor cocktail.[1]
  - Incubate the lysate on ice for 30 minutes, with brief vortexing every 10 minutes.
  - Clarify the lysate by centrifugation at 14,000 x g for 15 minutes at 4°C.[1]
  - Determine the protein concentration of the supernatant using a BCA or Bradford assay.[1]
  - Normalize protein concentrations and prepare samples by adding Laemmli buffer and heating at 95-100°C for 5-10 minutes.[1]
- SDS-PAGE and Protein Transfer:
  - Load 20-40 µg of total protein per lane onto an SDS-polyacrylamide gel.[1]
  - Perform electrophoresis to separate proteins by size.
  - Transfer the separated proteins to a PVDF or nitrocellulose membrane.[13]
- Immunodetection:
  - Block the membrane with 5% non-fat dry milk or 5% BSA in TBST for at least 1 hour at room temperature.[1]
  - Incubate the membrane with a primary antibody specific for MYC, diluted in blocking buffer, overnight at 4°C with gentle agitation.[1][7]
  - Wash the membrane three times for 10-15 minutes each with TBST.[7]

- Incubate the membrane with an appropriate HRP-conjugated secondary antibody diluted in blocking buffer for 1 hour at room temperature.[1]
- Wash the membrane three times for 10-15 minutes each with TBST.[7]
- Signal Detection:
  - Incubate the membrane with an enhanced chemiluminescence (ECL) substrate.[1]
  - Visualize the signal using an imaging system.

## Visualizations

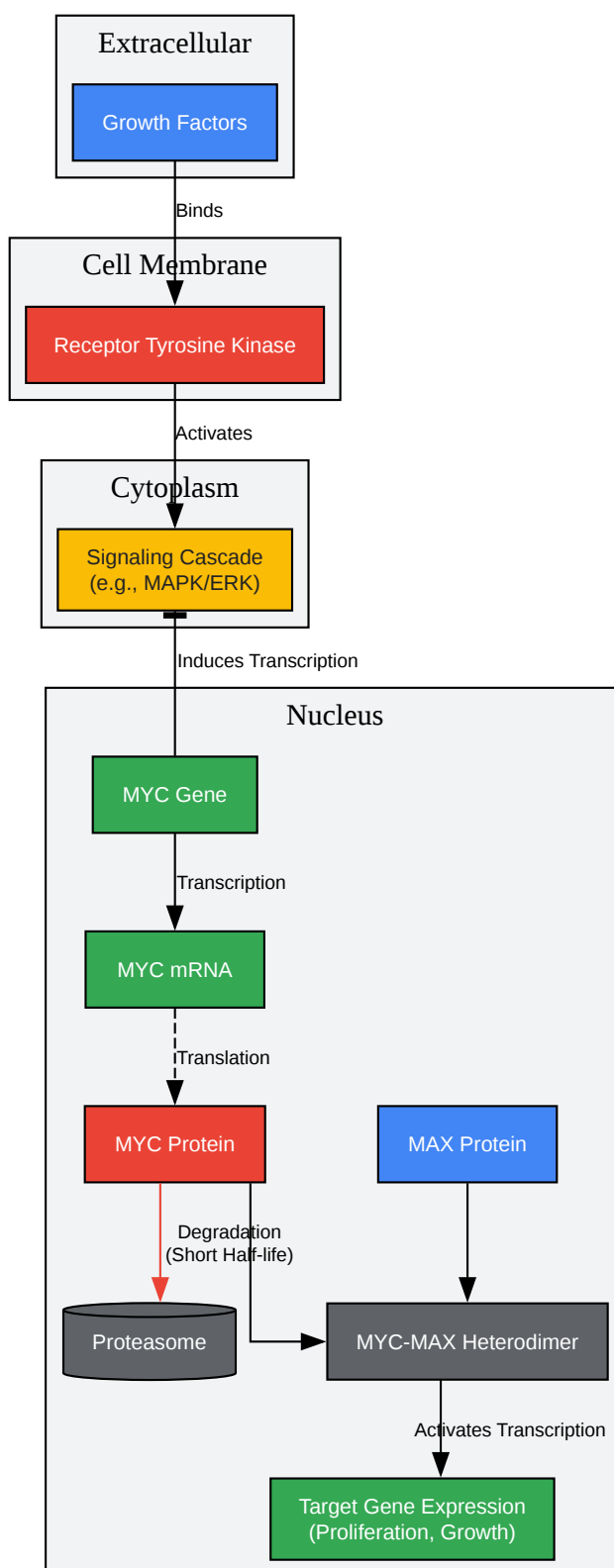

[Click to download full resolution via product page](#)

Caption: Simplified signaling pathway illustrating the regulation of MYC expression and function.

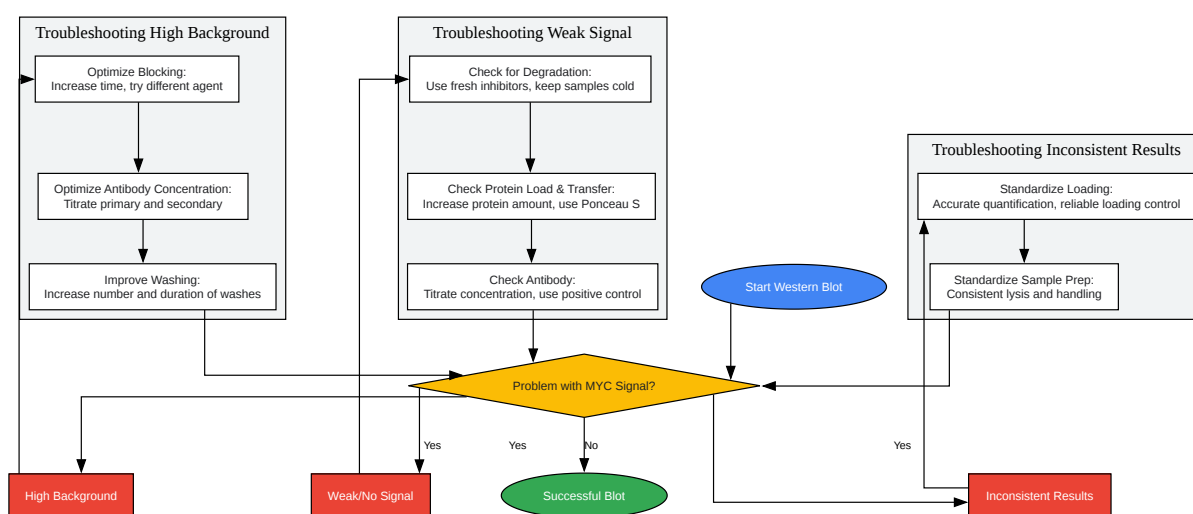

[Click to download full resolution via product page](#)

Caption: A workflow for troubleshooting common issues in MYC Western blot analysis.

**Need Custom Synthesis?**

BenchChem offers custom synthesis for rare earth carbides and specific isotopic labeling.

Email: [info@benchchem.com](mailto:info@benchchem.com) or [Request Quote Online](#).

## References

- [1. benchchem.com \[benchchem.com\]](#)
- [2. resources.biomol.com \[resources.biomol.com\]](#)
- [3. info.gbiosciences.com \[info.gbiosciences.com\]](#)
- [4. Expressions of commonly used housekeeping proteins are altered in asthmatic mouse lungs - PMC \[pmc.ncbi.nlm.nih.gov\]](#)
- [5. bio-rad-antibodies.com \[bio-rad-antibodies.com\]](#)
- [6. blog.addgene.org \[blog.addgene.org\]](#)
- [7. benchchem.com \[benchchem.com\]](#)
- [8. c-Myc \(MYC\) | Abcam \[abcam.com\]](#)
- [9. researchgate.net \[researchgate.net\]](#)
- [10. Western Blot Troubleshooting: High Background | Proteintech Group \[ptglab.com\]](#)
- [11. clyte.tech \[clyte.tech\]](#)
- [12. sinobiological.com \[sinobiological.com\]](#)
- [13. Detection of  \$\beta\$ -catenin and c-Myc protein expression by western blot analysis \[bio-protocol.org\]](#)
- To cite this document: BenchChem. [Technical Support Center: MYC Western Blot Analysis]. BenchChem, [2026]. [Online PDF]. Available at: [\[https://www.benchchem.com/product/b12367790/docs#technical-support-center-myc-western-blot-analysis\]](https://www.benchchem.com/product/b12367790/docs#technical-support-center-myc-western-blot-analysis)

---

### Disclaimer & Data Validity:

The information provided in this document is for Research Use Only (RUO) and is strictly not intended for diagnostic or therapeutic procedures. While BenchChem strives to provide accurate protocols, we make no warranties, express or implied, regarding the fitness of this product for every specific experimental setup.

**Technical Support:** The protocols provided are for reference purposes. Unsure if this reagent suits your experiment?

**Need Industrial/Bulk Grade?** [Request Custom Synthesis Quote](#)

# BenchChem

Our mission is to be the trusted global source of essential and advanced chemicals, empowering scientists and researchers to drive progress in science and industry.

## Contact

Address: 3281 E Guasti Rd  
Ontario, CA 91761, United States  
Phone: (601) 213-4426  
Email: [info@benchchem.com](mailto:info@benchchem.com)

[Contact our Ph.D. Support Team for a compatibility check](#)