

LRRK2-IN-1 Technical Support Center: Enhancing Experimental Reproducibility

Author: BenchChem Technical Support Team. **Date:** May 2026

Compound of Interest

Compound Name: LRRK2-IN-13

Cat. No.: B12367168

[Get Quote](#)

This technical support center provides researchers, scientists, and drug development professionals with comprehensive guidance for conducting experiments using the LRRK2 inhibitor, LRRK2-IN-1. Our aim is to improve the reproducibility of your findings through detailed troubleshooting guides, frequently asked questions (FAQs), and standardized experimental protocols.

Frequently Asked Questions (FAQs)

Q1: What is LRRK2-IN-1 and what is its primary mechanism of action?

A1: LRRK2-IN-1 is a potent and selective inhibitor of Leucine-Rich Repeat Kinase 2 (LRRK2). [1][2][3] It functions by competing with ATP for the binding site in the kinase domain of LRRK2, thereby preventing the phosphorylation of LRRK2 itself (autophosphorylation) and its downstream substrates.[4] A hallmark of its cellular activity is the dose-dependent dephosphorylation of LRRK2 at serine 910 (Ser910) and serine 935 (Ser935), which leads to a loss of 14-3-3 protein binding and alters the cytoplasmic localization of LRRK2.[1][5][6]

Q2: What are the recommended storage and handling conditions for LRRK2-IN-1?

A2: For long-term stability, LRRK2-IN-1 should be stored as a solid at -20°C. Stock solutions are typically prepared in dimethyl sulfoxide (DMSO).[2][3] It is advisable to aliquot the DMSO stock solution into smaller volumes to avoid repeated freeze-thaw cycles. For long-term storage of stock solutions, -80°C is recommended for up to a year, while -20°C is suitable for up to six months.[1]

Q3: What is the solubility of LRRK2-IN-1?

A3: LRRK2-IN-1 is soluble in DMSO at concentrations up to 100 mM.[3] When preparing working solutions in aqueous buffers or cell culture media, it is crucial to ensure the final DMSO concentration is kept low (typically below 0.5%, ideally 0.1% or lower) to avoid precipitation and solvent-induced cytotoxicity.[7]

Q4: Does LRRK2-IN-1 have known off-target effects?

A4: While LRRK2-IN-1 is a selective LRRK2 inhibitor, some off-target activities have been reported. It has been shown to inhibit MAPK7 with an EC50 of 160 nM and DCLK2 with an IC50 of 45 nM.[1] For some cellular readouts, like neurite outgrowth in primary neurons, LRRK2-IN-1 has shown similar effects in both normal and LRRK2 knockout cells, suggesting potential off-target activity in certain contexts.[8]

Q5: What are the known cytotoxic and genotoxic concentrations of LRRK2-IN-1?

A5: LRRK2-IN-1 can exhibit cytotoxicity at higher concentrations. For instance, the IC50 for cytotoxicity in HepG2 cells is 49.3 µM. Genotoxicity has been observed at lower concentrations, specifically at 3.9 µM without S9 metabolic activation and 15.6 µM with S9.[1] It is essential to determine the optimal, non-toxic concentration for your specific cell line and experimental conditions.

Quantitative Data Summary

The following tables provide a summary of key quantitative data for LRRK2-IN-1 to facilitate experimental design and data interpretation.

Table 1: Inhibitory Potency of LRRK2-IN-1

Target	Assay Type	IC50 Value	Reference(s)
LRRK2 (Wild-Type)	Biochemical	13 nM	[1][2][3]
LRRK2 (G2019S Mutant)	Biochemical	6 nM	[1][2][3]
LRRK2 (Wild-Type)	Cell-based (TR-FRET)	0.08 μ M	[1]
LRRK2 (G2019S Mutant)	Cell-based (TR-FRET)	0.03 μ M	[1]

Table 2: Off-Target Activity of LRRK2-IN-1

Off-Target	Assay Type	IC50/EC50 Value	Reference(s)
DCLK2	Biochemical	45 nM	[1]
MAPK7	Cell-based	160 nM	[1]
AURKB, CHEK2, MKNK2, MYLK, NUA1, PLK1	Biochemical	> 1 μ M	[1]

Table 3: Cytotoxicity and Genotoxicity of LRRK2-IN-1

Effect	Cell Line	Condition	Concentration	Reference(s)
Cytotoxicity (IC50)	HepG2	-	49.3 μ M	[1]
Genotoxicity	-	Without S9	3.9 μ M	[1]
Genotoxicity	-	With S9	15.6 μ M	[1]

Troubleshooting Guides

Issue 1: High Variability in Experimental Results

Question: My results with LRRK2-IN-1 are inconsistent between experiments. What could be the cause and how can I improve reproducibility?

Answer:

Potential Cause	Troubleshooting Steps
Inconsistent LRRK2-IN-1 Activity	<ol style="list-style-type: none">1. Freshly Prepare Working Dilutions: Avoid using old working dilutions of LRRK2-IN-1. Prepare fresh from a frozen DMSO stock for each experiment.2. Minimize Freeze-Thaw Cycles: Aliquot your DMSO stock solution to avoid repeated freeze-thaw cycles which can degrade the compound.^[7]3. Verify Stock Concentration: If possible, verify the concentration of your stock solution spectrophotometrically.
Cell Culture Variability	<ol style="list-style-type: none">1. Standardize Cell Seeding Density: Ensure a consistent number of cells are plated for each experiment.2. Control for Cell Passage Number: Use cells within a defined passage number range, as cellular responses can change with prolonged culturing.3. Monitor Cell Health: Regularly check for signs of stress or contamination in your cell cultures.
Assay Procedure Inconsistencies	<ol style="list-style-type: none">1. Standardize Incubation Times: Use a timer to ensure consistent incubation times for all treatments and assay steps.2. Ensure Uniform Reagent Mixing: Thoroughly but gently mix all reagents and solutions before adding them to your samples.3. Calibrate Equipment: Regularly calibrate pipettes, plate readers, and other equipment to ensure accuracy.

Issue 2: No or Weak Inhibition of LRRK2 Activity

Question: I am not observing the expected inhibition of LRRK2 phosphorylation (e.g., pSer935) after treating with LRRK2-IN-1. What should I check?

Answer:

Potential Cause	Troubleshooting Steps
Suboptimal LRRK2-IN-1 Concentration	<ol style="list-style-type: none"> 1. Perform a Dose-Response Curve: Determine the optimal concentration of LRRK2-IN-1 for your specific cell line and experimental conditions. A good starting range is 10 nM to 1 μM. 2. Increase Incubation Time: The inhibitory effect may be time-dependent. Try increasing the incubation time with LRRK2-IN-1.
Low LRRK2 Expression or Activity	<ol style="list-style-type: none"> 1. Use a Positive Control Cell Line: Use a cell line known to express high levels of LRRK2 (e.g., A549) or cells overexpressing LRRK2 to validate your assay.^[9] 2. Stimulate LRRK2 Activity: In some cell types, LRRK2 activity may be low under basal conditions. Consider stimulating cells with an appropriate agent if applicable to your experimental question.
Western Blotting Issues	<ol style="list-style-type: none"> 1. Optimize Antibody Concentrations: Titrate your primary and secondary antibodies to find the optimal concentrations for detecting phosphorylated and total LRRK2.^[10] 2. Use Fresh Lysis Buffer with Inhibitors: Prepare fresh lysis buffer containing protease and phosphatase inhibitors to prevent protein degradation and dephosphorylation.^{[11][12]} 3. Ensure Efficient Protein Transfer: Given the large size of LRRK2 (~286 kDa), ensure complete transfer by using a lower percentage acrylamide gel and optimizing transfer conditions (e.g., overnight transfer at a low voltage).^[10]

Issue 3: Cell Toxicity or Unexpected Phenotypes

Question: I am observing cell death or other unexpected phenotypes in my LRRK2-IN-1 treated cells. How can I address this?

Answer:

Potential Cause	Troubleshooting Steps
LRRK2-IN-1 Cytotoxicity	<p>1. Determine the Optimal Non-Toxic Concentration: Perform a cell viability assay (e.g., MTT or LDH assay) to determine the highest concentration of LRRK2-IN-1 that does not affect the viability of your cells.[13]</p> <p>2. Reduce Incubation Time: Shorter incubation times may be sufficient to achieve LRRK2 inhibition without causing significant toxicity.</p>
High DMSO Concentration	<p>1. Maintain Low Final DMSO Concentration: Ensure the final concentration of DMSO in your cell culture medium is non-toxic for your cell line (typically $\leq 0.1\%$).[7]</p> <p>2. Include a Vehicle Control: Always include a vehicle control (cells treated with the same final concentration of DMSO as your LRRK2-IN-1 treated cells) to distinguish between compound-specific effects and solvent effects.</p>
Off-Target Effects	<p>1. Use a Negative Control: If possible, use a structurally related but inactive compound as a negative control.</p> <p>2. Validate with a Second LRRK2 Inhibitor: Confirm your findings with a structurally different LRRK2 inhibitor to ensure the observed phenotype is due to LRRK2 inhibition.</p> <p>3. Utilize LRRK2 Knockout/Knockdown Cells: The most rigorous control is to test the effect of LRRK2-IN-1 in cells lacking LRRK2. An on-target effect should be absent in these cells.[8]</p>

Experimental Protocols

Protocol 1: Western Blot for LRRK2 Phosphorylation

This protocol describes a method to assess the inhibitory effect of LRRK2-IN-1 by measuring the phosphorylation of LRRK2 at Ser935.

Materials:

- Cells of interest
- LRRK2-IN-1
- Complete cell culture medium
- Phosphate-buffered saline (PBS)
- Lysis buffer (e.g., RIPA buffer) supplemented with protease and phosphatase inhibitors
- BCA protein assay kit
- SDS-PAGE gels (low percentage, e.g., 6-8%)
- Transfer buffer
- PVDF or nitrocellulose membrane
- Blocking buffer (e.g., 5% non-fat dry milk or BSA in TBST)
- Primary antibodies (anti-pSer935-LRRK2 and anti-total LRRK2)
- HRP-conjugated secondary antibody
- Enhanced chemiluminescence (ECL) substrate

Procedure:

- Cell Seeding and Treatment:

- Seed cells at an appropriate density in a multi-well plate and allow them to adhere overnight.
- Treat cells with varying concentrations of LRRK2-IN-1 (and a DMSO vehicle control) for the desired duration.
- Cell Lysis:
 - Wash cells with ice-cold PBS.
 - Lyse cells in ice-cold lysis buffer containing protease and phosphatase inhibitors.
 - Centrifuge the lysates to pellet cell debris and collect the supernatant.
- Protein Quantification:
 - Determine the protein concentration of each lysate using a BCA assay.
- SDS-PAGE and Western Blotting:
 - Normalize protein amounts and prepare samples with Laemmli buffer.
 - Separate proteins on a low-percentage SDS-PAGE gel.
 - Transfer proteins to a PVDF or nitrocellulose membrane.
 - Block the membrane with blocking buffer for 1 hour at room temperature.
 - Incubate the membrane with primary antibodies (e.g., anti-pSer935-LRRK2 and anti-total LRRK2) overnight at 4°C.
 - Wash the membrane with TBST.
 - Incubate the membrane with an HRP-conjugated secondary antibody for 1 hour at room temperature.
 - Wash the membrane with TBST.
 - Detect the signal using an ECL substrate and an imaging system.

- Data Analysis:
 - Quantify the band intensities for pSer935-LRRK2 and total LRRK2.
 - Normalize the pSer935-LRRK2 signal to the total LRRK2 signal for each sample.

Protocol 2: Cell-Based LRRK2 Kinase Assay (TR-FRET)

This protocol provides a high-throughput method to measure LRRK2 inhibition in a cellular context using Time-Resolved Fluorescence Resonance Energy Transfer (TR-FRET).

Materials:

- Cells expressing LRRK2 (e.g., U-2 OS, SH-SY5Y)
- BacMam LRRK2-GFP (or other suitable expression system)
- LRRK2-IN-1
- Assay buffer
- Lysis buffer
- TR-FRET detection reagents (e.g., terbium-conjugated anti-GFP antibody and a fluorescently labeled anti-pSer935 antibody)
- 384-well assay plates
- Plate reader capable of TR-FRET measurements

Procedure:

- Cell Transduction and Seeding:
 - Transduce cells with BacMam LRRK2-GFP at an optimized concentration.
 - Seed the transduced cells into a 384-well assay plate and incubate overnight.
- Compound Treatment:

- Treat the cells with a serial dilution of LRRK2-IN-1 (and a DMSO vehicle control) for 90 minutes.[6]
- Cell Lysis:
 - Lyse the cells directly in the wells by adding lysis buffer.
- TR-FRET Detection:
 - Add the TR-FRET detection reagents to each well.
 - Incubate the plate at room temperature to allow for antibody binding.
- Data Acquisition and Analysis:
 - Measure the fluorescence emission at two wavelengths (e.g., 520 nm and 495 nm).[6]
 - Calculate the emission ratio (e.g., 520 nm / 495 nm) for each well.
 - Plot the emission ratio against the concentration of LRRK2-IN-1 to generate a dose-response curve and calculate the IC50 value.

Visualizations

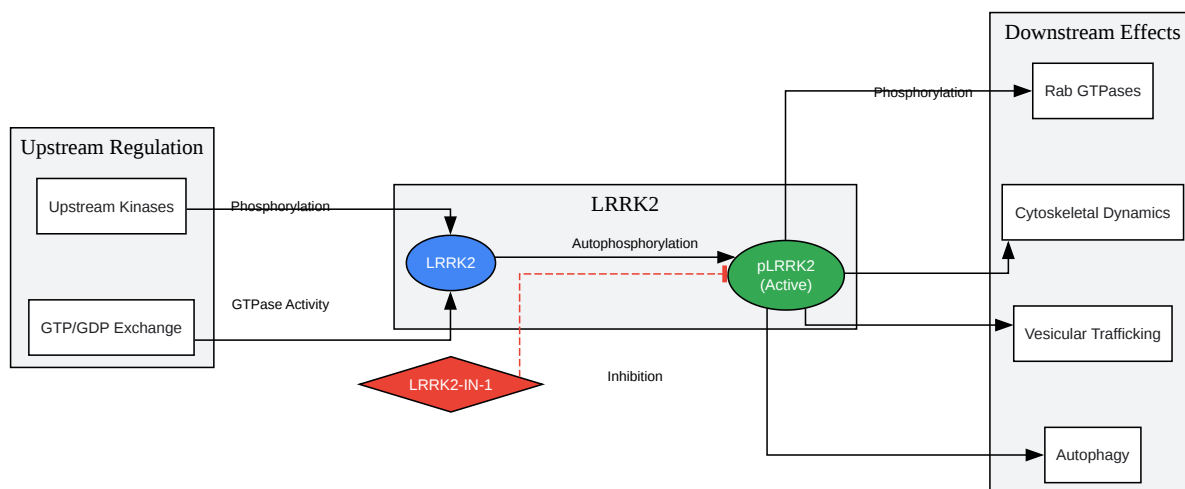

[Click to download full resolution via product page](#)

Caption: LRRK2 Signaling Pathway and Inhibition by LRRK2-IN-1.

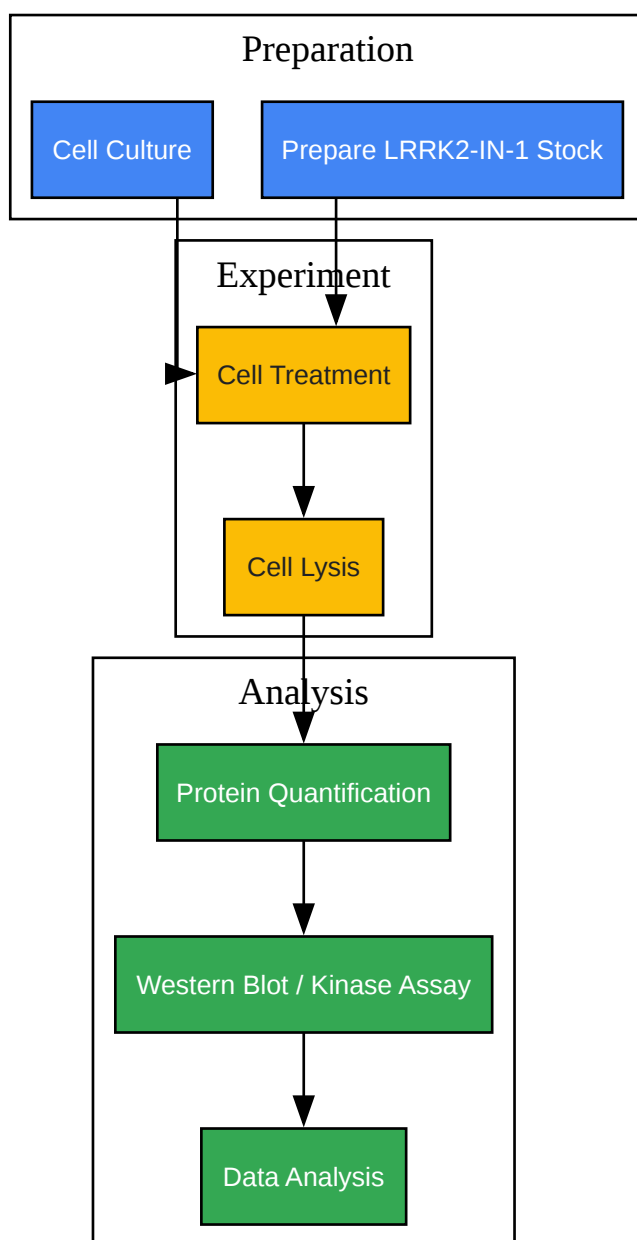

[Click to download full resolution via product page](#)

Caption: General Experimental Workflow for LRRK2-IN-1 Studies.

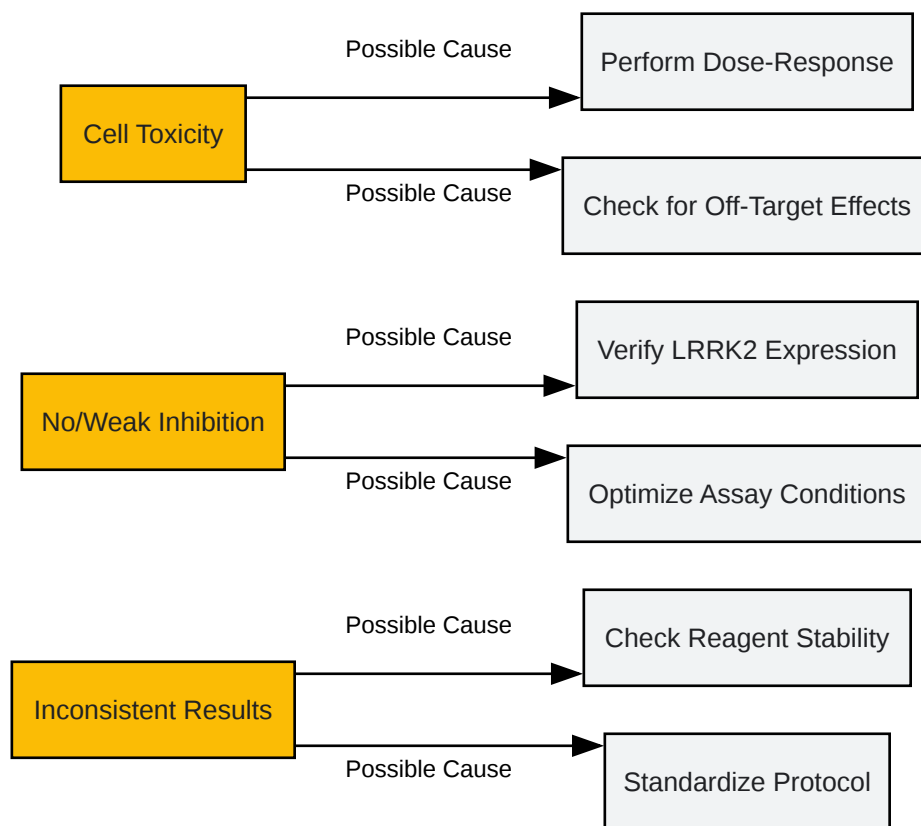

[Click to download full resolution via product page](#)

Caption: Troubleshooting Decision Tree for LRRK2-IN-1 Experiments.

Need Custom Synthesis?

BenchChem offers custom synthesis for rare earth carbides and specific isotopic labeling.

Email: info@benchchem.com or [Request Quote Online](#).

References

- 1. [medchemexpress.com](https://www.medchemexpress.com) [[medchemexpress.com](https://www.medchemexpress.com)]
- 2. [selleckchem.com](https://www.selleckchem.com) [[selleckchem.com](https://www.selleckchem.com)]
- 3. LRRK2-IN-1 | LRRK2 | Tocris Bioscience [[toocris.com](https://www.tocris.com)]
- 4. LRRK2 Targeting Strategies as Potential Treatment of Parkinson's Disease - PMC [[pmc.ncbi.nlm.nih.gov](https://pubmed.ncbi.nlm.nih.gov)]

- [5. Screening for Novel LRRK2 Inhibitors Using a High-Throughput TR-FRET Cellular Assay for LRRK2 Ser935 Phosphorylation | PLOS One \[journals.plos.org\]](#)
- [6. Screening for Novel LRRK2 Inhibitors Using a High-Throughput TR-FRET Cellular Assay for LRRK2 Ser935 Phosphorylation - PMC \[pmc.ncbi.nlm.nih.gov\]](#)
- [7. benchchem.com \[benchchem.com\]](#)
- [8. LRRK2 Kinase Inhibition as a Therapeutic Strategy for Parkinson's Disease, Where Do We Stand? - PMC \[pmc.ncbi.nlm.nih.gov\]](#)
- [9. researchgate.net \[researchgate.net\]](#)
- [10. researchgate.net \[researchgate.net\]](#)
- [11. Western blotting for LRRK2 signalling in macrophages \[protocols.io\]](#)
- [12. Western Blotting Troubleshooting Guide | Cell Signaling Technology \[cellsignal.com\]](#)
- [13. benchchem.com \[benchchem.com\]](#)
- To cite this document: BenchChem. [LRRK2-IN-1 Technical Support Center: Enhancing Experimental Reproducibility]. BenchChem, [2026]. [Online PDF]. Available at: [\[https://www.benchchem.com/product/b12367168/docs#lrrk2-in-1-technical-support-center-enhancing-experimental-reproducibility\]](https://www.benchchem.com/product/b12367168/docs#lrrk2-in-1-technical-support-center-enhancing-experimental-reproducibility)

Disclaimer & Data Validity:

The information provided in this document is for Research Use Only (RUO) and is strictly not intended for diagnostic or therapeutic procedures. While BenchChem strives to provide accurate protocols, we make no warranties, express or implied, regarding the fitness of this product for every specific experimental setup.

Technical Support: The protocols provided are for reference purposes. Unsure if this reagent suits your experiment?

Need Industrial/Bulk Grade? [Request Custom Synthesis Quote](#)

BenchChem

Our mission is to be the trusted global source of essential and advanced chemicals, empowering scientists and researchers to drive progress in science and industry.

Contact

Address: 3281 E Guasti Rd

Ontario, CA 91761, United States

Phone: (601) 213-4426

Email: info@benchchem.com

[Contact our Ph.D. Support Team for a compatibility check](#)