

Independent Verification of BM30's Specificity: A Comparative Guide for Researchers

Author: BenchChem Technical Support Team. **Date:** April 2026

Compound of Interest

Compound Name: *BM30*
Cat. No.: *B12367058*

[Get Quote](#)

For researchers, scientists, and drug development professionals, the specificity of a chemical probe is paramount. This guide provides an objective comparison of **BM30**, a potent peptidomimetic inhibitor of N-terminal methyltransferase 1/2 (NTMT1/2), with other alternatives, supported by experimental data from independent verification studies.

BM30 has emerged as a valuable tool for studying the biological functions of NTMT1/2, enzymes implicated in crucial cellular processes such as mitosis and DNA damage repair.^{[1][2]} This document collates available data to offer a clear perspective on its performance and specificity.

Comparative Analysis of NTMT1/2 Inhibitors

The following table summarizes the inhibitory potency of **BM30** and its analogs, along with other reported NTMT1/2 inhibitors. This quantitative data allows for a direct comparison of their efficacy.

Inhibitor	Type	Target(s)	IC50 / Ki	Key Findings
BM30	Peptidomimetic	NTMT1/2	IC50: 0.89 ± 0.10 μ M	First potent and highly selective peptidomimetic inhibitor.[1][2]
DC432	Peptidomimetic (BM30 analog)	NTMT1/2	IC50: 54 ± 4 nM	Cell-permeable analog of BM30. [1][2]
DC113	Peptidomimetic (BM30 analog)	NTMT1	IC50: 0.1 ± 0.01 μ M	Improved inhibitory activity and cell permeability over BM30.[3]
GD562	Peptidomimetic (BM30 analog)	NTMT1	IC50: 0.93 ± 0.04 μ M	Improved cellular inhibition of N-terminal methylation compared to other analogs.[3]
NAM-TZ-SPKRIA	Bisubstrate Analog	NTMT1	Ki: 0.20 μ M	Potent and selective, demonstrating a different inhibition strategy.[4]
Compound 4	Bisubstrate Analog	NTMT1	IC50: 35 ± 2 nM	Highly potent bisubstrate inhibitor with excellent selectivity.[5]

Specificity Profile of BM30

A key aspect of a chemical probe's utility is its selectivity for the intended target over other related proteins. **BM30** was profiled against a panel of 41 methyltransferases to assess its specificity. The results demonstrate that **BM30** has minimal inhibitory activity against a wide range of other methyltransferases, confirming its high selectivity for NTMT1/2.[\[1\]](#)

Summary of **BM30** Selectivity Data:[\[1\]](#)

Methyltransferase Class	Number Tested	Observation
Protein Lysine Methyltransferases (PKMTs)	>20	Marginal inhibition at 100 μ M
Protein Arginine Methyltransferases (PRMTs)	>5	Marginal inhibition at 100 μ M
DNA Methyltransferases (DNMTs)	>3	Marginal inhibition at 100 μ M
Other Methyltransferases	~10	Marginal inhibition at 100 μ M

Note: The complete list of the 41 tested methyltransferases can be found in the supplementary information of the primary publication by Mackie et al., 2020, J. Med. Chem.

Experimental Protocols

For the independent verification and comparison of NTMT1/2 inhibitors, the following experimental methodologies are commonly employed.

In Vitro Methyltransferase Inhibition Assay (ThioGlo-based)

This assay quantifies the activity of methyltransferases by detecting the production of S-adenosyl-L-homocysteine (SAH), a universal by-product of methylation reactions.

Materials:

- Purified NTMT1 or NTMT2 enzyme

- Peptide substrate (e.g., RCC1-6)
- S-adenosyl-L-methionine (SAM)
- SAH hydrolase (SAHH)
- ThioGlo1, ThioGlo3, or ThioGlo4
- Assay buffer (e.g., 25 mM Tris-HCl pH 7.5, 50 mM KCl, 0.01% Triton X-100)
- Test inhibitors (e.g., **BM30**)

Procedure:

- Prepare a reaction mixture containing the assay buffer, SAHH, and the test inhibitor at various concentrations.
- Add the NTMT enzyme to the mixture and incubate.
- Initiate the methylation reaction by adding SAM and the peptide substrate.
- Add the ThioGlo reagent, which fluoresces upon reacting with the free thiol group of homocysteine produced from SAH by SAHH.
- Measure the fluorescence intensity using a microplate reader.
- Calculate the IC₅₀ values by plotting the percentage of inhibition against the inhibitor concentration.

Cellular N-terminal Methylation Assay (Western Blot)

This method assesses the ability of an inhibitor to penetrate cells and inhibit NTMT1/2 activity on endogenous substrates.

Materials:

- Cell line expressing the target substrate (e.g., HCT116 cells for RCC1 and SET proteins)
- Cell-permeable test inhibitor (e.g., DC432)

- Cell lysis buffer
- Primary antibody specific to the methylated N-terminal motif (e.g., anti-me3-SPK)
- Secondary antibody conjugated to a detectable enzyme (e.g., HRP-conjugated anti-rabbit IgG)
- Chemiluminescent substrate
- Protein electrophoresis and blotting equipment

Procedure:

- Culture the cells in the presence of varying concentrations of the test inhibitor for a specified period (e.g., 72 hours).
- Lyse the cells to extract total protein.
- Separate the proteins by size using SDS-PAGE.
- Transfer the separated proteins to a PVDF or nitrocellulose membrane.
- Block the membrane to prevent non-specific antibody binding.
- Incubate the membrane with the primary antibody that recognizes the methylated substrate.
- Wash the membrane and incubate with the secondary antibody.
- Add the chemiluminescent substrate and detect the signal using an imaging system.
- Quantify the band intensities to determine the extent of inhibition of cellular methylation.[\[6\]](#)[\[7\]](#)
[\[8\]](#)[\[9\]](#)

Visualizing NTMT1/2's Role in Cellular Pathways

To provide a conceptual framework for the function of NTMT1/2, the following diagrams illustrate the experimental workflow for inhibitor testing and the signaling pathways in which these enzymes are involved.

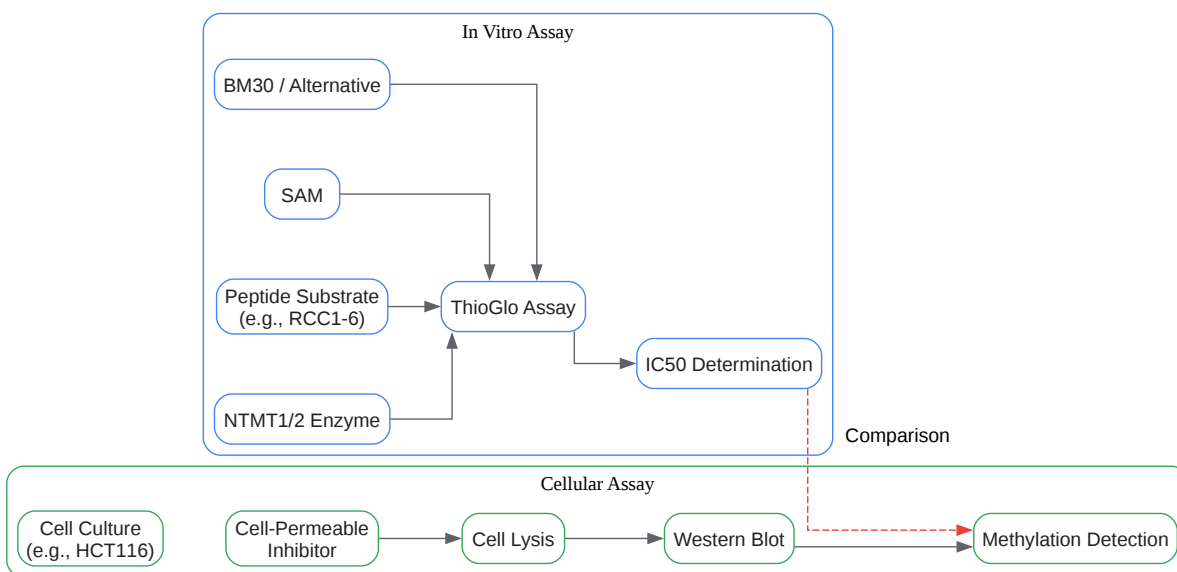

[Click to download full resolution via product page](#)

Experimental workflow for inhibitor specificity testing.

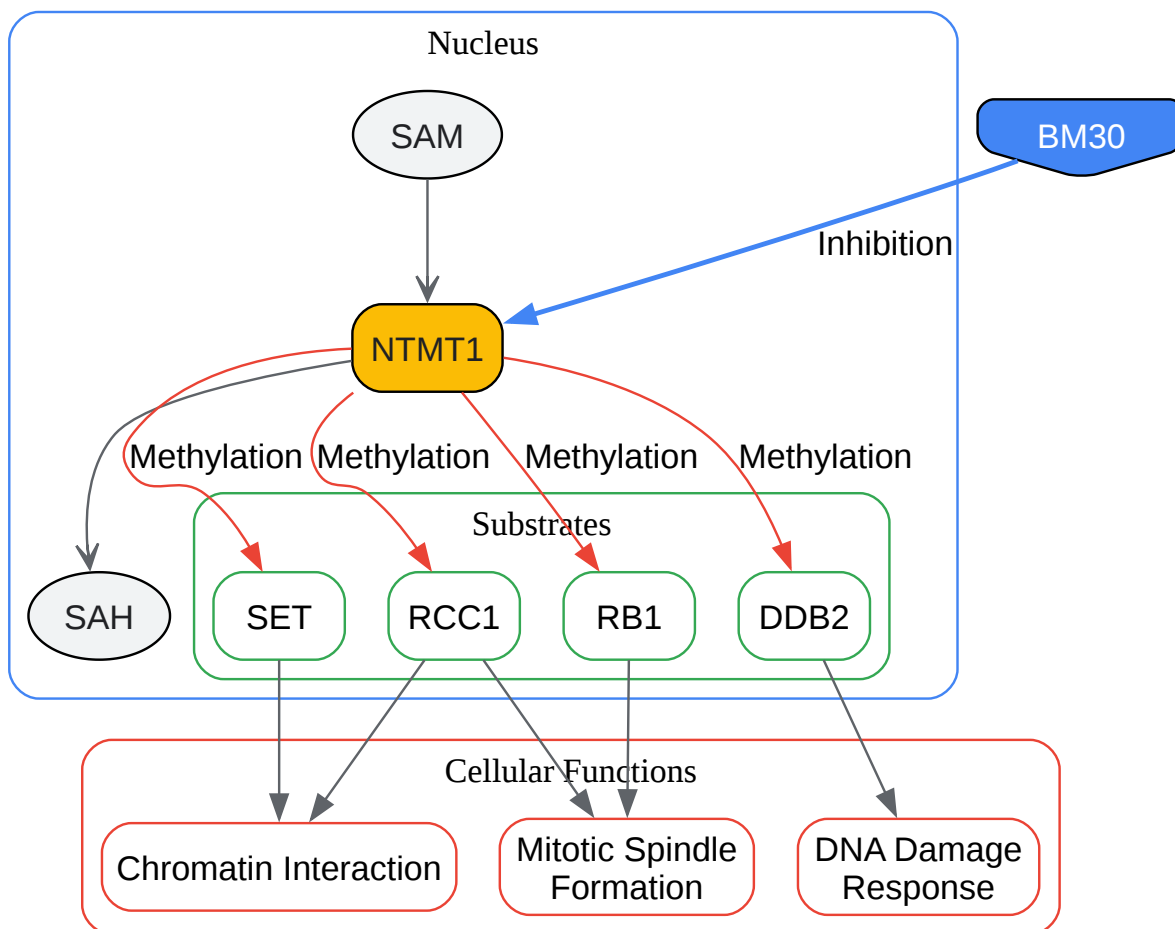

[Click to download full resolution via product page](#)

NTMT1 signaling pathway and point of inhibition by **BM30**.

Need Custom Synthesis?

BenchChem offers custom synthesis for rare earth carbides and specific isotopic labeling.

Email: info@benchchem.com or [Request Quote Online](#).

References

- 1. Selective Peptidomimetic Inhibitors of NTMT1/2: Rational design, synthesis, characterization, and crystallographic studies - PMC [[pmc.ncbi.nlm.nih.gov](https://pubmed.ncbi.nlm.nih.gov/)]

- [2. Selective Peptidomimetic Inhibitors of NTMT1/2: Rational Design, Synthesis, Characterization, and Crystallographic Studies - PubMed \[pubmed.ncbi.nlm.nih.gov\]](#)
- [3. mdpi.com \[mdpi.com\]](#)
- [4. Design, synthesis, and kinetic analysis of potent protein N-terminal methyltransferase 1 inhibitors - PMC \[pmc.ncbi.nlm.nih.gov\]](#)
- [5. Discovery of Bisubstrate Inhibitors for Protein N-Terminal Methyltransferase 1 - PMC \[pmc.ncbi.nlm.nih.gov\]](#)
- [6. pubcompare.ai \[pubcompare.ai\]](#)
- [7. Western Blot \(WB\) Protocol | EpigenTek \[epigentek.com\]](#)
- [8. Western blot protocol | Abcam \[abcam.com\]](#)
- [9. Western Blot Protocol | Proteintech Group \[ptglab.com\]](#)
- [To cite this document: BenchChem. \[Independent Verification of BM30's Specificity: A Comparative Guide for Researchers\]. BenchChem, \[2026\]. \[Online PDF\]. Available at: \[https://www.benchchem.com/product/b12367058/docs#independent-verification-of-bm30-s-specificity-a-comparative-guide-for-researchers\]](#)

Disclaimer & Data Validity:

The information provided in this document is for Research Use Only (RUO) and is strictly not intended for diagnostic or therapeutic procedures. While BenchChem strives to provide accurate protocols, we make no warranties, express or implied, regarding the fitness of this product for every specific experimental setup.

Technical Support: The protocols provided are for reference purposes. Unsure if this reagent suits your experiment?

Need Industrial/Bulk Grade? [Request Custom Synthesis Quote](#)

BenchChem

Our mission is to be the trusted global source of essential and advanced chemicals, empowering scientists and researchers to drive progress in science and industry.

Contact

Address: 3281 E Guasti Rd

Ontario, CA 91761, United States

Phone: (601) 213-4426

Email: info@benchchem.com

[Contact our Ph.D. Support Team for a compatibility check](#)