

PROTAC SOS1 Degradator-7: Application Notes and Protocols for Preclinical Research

Author: BenchChem Technical Support Team. **Date:** April 2026

Compound of Interest

Compound Name: PROTAC SOS1 degrader-7

Cat. No.: B12366329

[Get Quote](#)

For Researchers, Scientists, and Drug Development Professionals

Introduction

PROTAC SOS1 degrader-7, also referred to as P7 in some literature, is a heterobifunctional proteolysis-targeting chimera (PROTAC) designed to induce the targeted degradation of the Son of Sevenless 1 (SOS1) protein. SOS1 is a guanine nucleotide exchange factor (GEF) that plays a critical role in the activation of RAS proteins, pivotal nodes in the RAS/MAPK signaling pathway that governs cell proliferation, differentiation, and survival. Dysregulation of this pathway is a hallmark of many cancers, particularly those with KRAS mutations. By hijacking the ubiquitin-proteasome system, **PROTAC SOS1 degrader-7** offers a novel therapeutic strategy to eliminate the SOS1 protein, thereby inhibiting downstream RAS signaling and tumor growth. This document provides detailed application notes and experimental protocols for the preclinical evaluation of **PROTAC SOS1 degrader-7**.

Mechanism of Action

PROTAC SOS1 degrader-7 is composed of a ligand that binds to the SOS1 protein, a linker, and a ligand that recruits an E3 ubiquitin ligase, typically Cereblon (CRBN). This tripartite complex formation brings SOS1 into close proximity with the E3 ligase, leading to the

ubiquitination of SOS1 and its subsequent degradation by the proteasome. This event-driven pharmacology not only inhibits the enzymatic function of SOS1 but also eliminates its scaffolding functions, potentially leading to a more profound and durable inhibition of the RAS/MAPK pathway compared to traditional small molecule inhibitors.[1][2]

Data Presentation

Quantitative Analysis of PROTAC SOS1 Degradation-7 (P7) Activity

The following tables summarize the degradation potency and cytotoxic activity of **PROTAC SOS1 degrader-7 (P7)** in various colorectal cancer (CRC) cell lines.

Table 1: SOS1 Degradation Potency (DC₅₀) of P7 in Colorectal Cancer Cell Lines

Cell Line	DC ₅₀ (μM) at 24 hours	95% Confidence Interval (μM)
SW620	0.59	0.23–1.42
HCT116	0.75	0.27–1.98
SW1417	0.19	0.043–1.16

Data sourced from Bian et al., 2022.[1]

Table 2: Comparative Cytotoxic Activity in Patient-Derived CRC Organoids

Compound	Relative IC ₅₀
PROTAC SOS1 degrader-7 (P7)	5-fold lower than BI-3406
BI-3406 (SOS1 Inhibitor)	Reference

Data sourced from Bian et al., 2022.[1][3][4][5]

Mandatory Visualizations

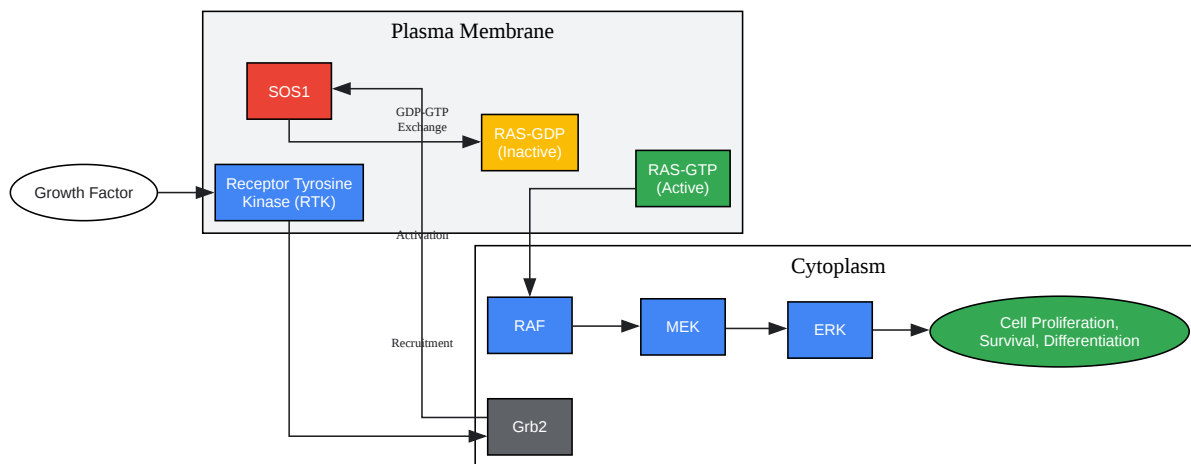

[Click to download full resolution via product page](#)

Caption: SOS1-mediated RAS/MAPK signaling pathway.

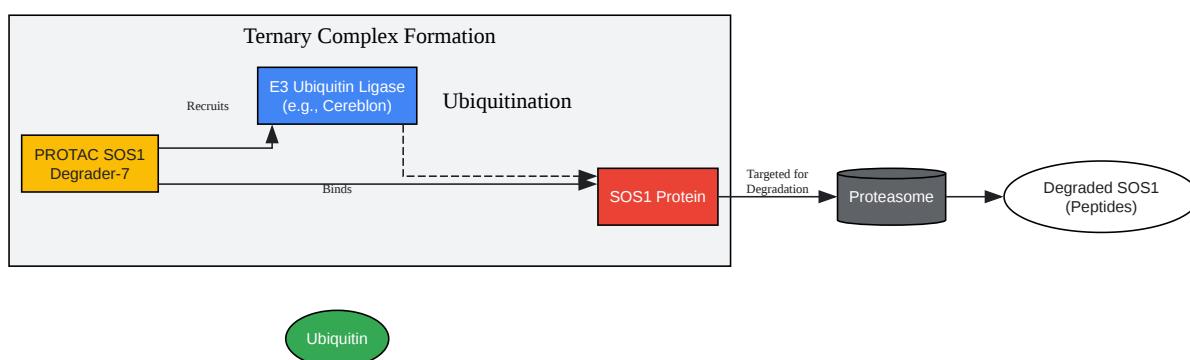

[Click to download full resolution via product page](#)

Caption: Mechanism of action of **PROTAC SOS1 degrader-7**.

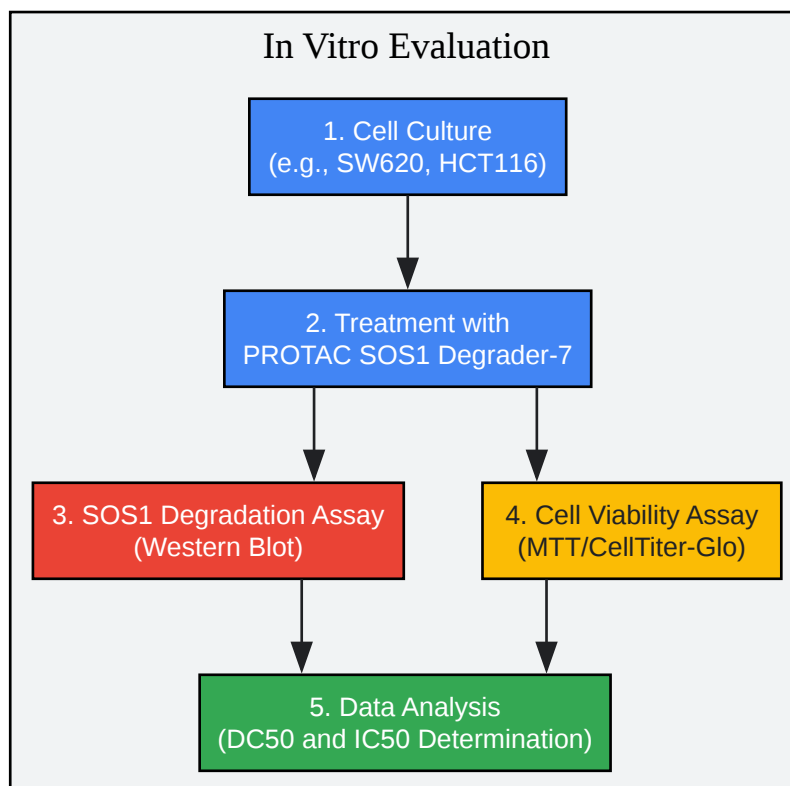

[Click to download full resolution via product page](#)

Caption: Experimental workflow for evaluating **PROTAC SOS1 degrader-7**.

Experimental Protocols

SOS1 Protein Degradation Assay by Western Blot

This protocol details the methodology to assess the dose-dependent degradation of SOS1 protein in cancer cell lines following treatment with **PROTAC SOS1 degrader-7**.

Materials:

- Colorectal cancer cell lines (e.g., SW620, HCT116, SW1417)
- Complete cell culture medium (e.g., DMEM with 10% FBS)
- **PROTAC SOS1 degrader-7 (P7)**

- DMSO (vehicle control)
- Phosphate-buffered saline (PBS)
- RIPA lysis buffer supplemented with protease and phosphatase inhibitors
- BCA protein assay kit
- SDS-PAGE gels and running buffer
- Transfer buffer and PVDF membrane
- Blocking buffer (e.g., 5% non-fat milk or BSA in TBST)
- Primary antibodies: anti-SOS1 and anti-GAPDH (or other loading control)
- HRP-conjugated secondary antibody
- Enhanced chemiluminescence (ECL) substrate
- Chemiluminescence imaging system

Procedure:

- **Cell Seeding:** Seed cells in 6-well plates at a density that will result in 70-80% confluency at the time of harvest. Allow cells to adhere overnight.
- **Compound Treatment:** Prepare serial dilutions of **PROTAC SOS1 degrader-7** in complete culture medium. Aspirate the old medium from the cells and add the medium containing the degrader or DMSO (vehicle control). Incubate for the desired time points (e.g., 24, 48 hours).
- **Cell Lysis:** After incubation, wash the cells twice with ice-cold PBS. Add 100-200 μ L of ice-cold RIPA buffer to each well and scrape the cells.
- **Protein Quantification:** Centrifuge the lysates at 14,000 x g for 15 minutes at 4°C. Collect the supernatant and determine the protein concentration using a BCA protein assay.
- **SDS-PAGE and Western Blotting:**

- Normalize the protein concentrations and prepare samples with Laemmli buffer.
- Load equal amounts of protein onto an SDS-PAGE gel and run the electrophoresis.
- Transfer the separated proteins to a PVDF membrane.
- Block the membrane with blocking buffer for 1 hour at room temperature.
- Incubate the membrane with the primary anti-SOS1 antibody overnight at 4°C.
- Wash the membrane three times with TBST.
- Incubate with the HRP-conjugated secondary antibody for 1 hour at room temperature.
- Wash the membrane again three times with TBST.
- Apply ECL substrate and visualize the protein bands using a chemiluminescence imaging system.
- Strip the membrane and re-probe with an anti-GAPDH antibody as a loading control.
- Data Analysis: Quantify the band intensities using densitometry software. Normalize the SOS1 band intensity to the corresponding loading control. Calculate the percentage of SOS1 degradation relative to the vehicle-treated control. Plot the percentage of degradation against the logarithm of the degrader concentration to determine the DC₅₀ value.[\[1\]](#)

Cell Viability Assay (MTT Assay)

This protocol describes how to measure the effect of **PROTAC SOS1 degrader-7** on the viability of cancer cell lines.

Materials:

- Cancer cell lines
- Complete cell culture medium
- **PROTAC SOS1 degrader-7**

- DMSO
- 96-well plates
- MTT (3-(4,5-dimethylthiazol-2-yl)-2,5-diphenyltetrazolium bromide) solution (5 mg/mL in PBS)
- Solubilization solution (e.g., DMSO or a solution of 10% SDS in 0.01 M HCl)
- Microplate reader

Procedure:

- **Cell Seeding:** Seed cells in a 96-well plate at a density of 5,000-10,000 cells per well in 100 μ L of complete medium. Allow cells to attach overnight.
- **Compound Treatment:** Prepare serial dilutions of **PROTAC SOS1 degrader-7** in culture medium. Add the compound solutions to the respective wells. Include wells with vehicle control (DMSO) and wells with medium only (for background control).
- **Incubation:** Incubate the plate for the desired duration (e.g., 72 hours) at 37°C in a humidified incubator with 5% CO₂.
- **MTT Addition:** Add 10 μ L of MTT solution to each well and incubate for 2-4 hours at 37°C, allowing viable cells to reduce the yellow MTT to purple formazan crystals.
- **Solubilization:** Add 100 μ L of solubilization solution to each well to dissolve the formazan crystals. Mix gently by pipetting up and down.
- **Absorbance Measurement:** Read the absorbance at a wavelength of 570 nm using a microplate reader.
- **Data Analysis:** Subtract the background absorbance from all readings. Calculate the percentage of cell viability relative to the vehicle-treated control. Plot the percentage of viability against the logarithm of the degrader concentration to determine the IC₅₀ value.

Conclusion

PROTAC SOS1 degrader-7 represents a promising therapeutic agent for cancers driven by aberrant RAS signaling. The protocols and data presented in this document provide a framework for its preclinical evaluation. By inducing the targeted degradation of SOS1, this PROTAC has demonstrated potent and specific activity in relevant cancer models. Further investigation into its in vivo efficacy, pharmacokinetic and pharmacodynamic properties, and safety profile is warranted to advance its development as a potential cancer therapeutic.

Need Custom Synthesis?

BenchChem offers custom synthesis for rare earth carbides and specific isotopic labeling.

Email: info@benchchem.com or [Request Quote Online](#).

References

- [1. Development of SOS1 inhibitor-based degraders to target KRAS-mutant colorectal cancer - PMC \[pmc.ncbi.nlm.nih.gov\]](#)
- [2. Development of PROTACS degrading KRAS and SOS1 - PMC \[pmc.ncbi.nlm.nih.gov\]](#)
- [3. Development of SOS1 Inhibitor-Based Degraders to Target KRAS-Mutant Colorectal Cancer - PubMed \[pubmed.ncbi.nlm.nih.gov\]](#)
- [4. utsouthwestern.elsevierpure.com \[utsouthwestern.elsevierpure.com\]](#)
- [5. pubs.acs.org \[pubs.acs.org\]](#)
- To cite this document: BenchChem. [PROTAC SOS1 Degrader-7: Application Notes and Protocols for Preclinical Research]. BenchChem, [2026]. [Online PDF]. Available at: [<https://www.benchchem.com/product/b12366329/docs#protac-sos1-degrader-7-application-notes-and-protocols-for-preclinical-research>]

Disclaimer & Data Validity:

The information provided in this document is for Research Use Only (RUO) and is strictly not intended for diagnostic or therapeutic procedures. While BenchChem strives to provide accurate protocols, we make no warranties, express or implied, regarding the fitness of this product for every specific experimental setup.

Technical Support: The protocols provided are for reference purposes. Unsure if this reagent suits your experiment?

Need Industrial/Bulk Grade? [Request Custom Synthesis Quote](#)

BenchChem

Our mission is to be the trusted global source of essential and advanced chemicals, empowering scientists and researchers to drive progress in science and industry.

Contact

Address: 3281 E Guasti Rd
Ontario, CA 91761, United States
Phone: (601) 213-4426
Email: info@benchchem.com

[Contact our Ph.D. Support Team for a compatibility check](#)