

PP487 experimental variability and reproducibility issues

Author: BenchChem Technical Support Team. **Date:** April 2026

Compound of Interest

Compound Name: PP487
Cat. No.: B12366087

[Get Quote](#)

Technical Support Center: PP487

This technical support center provides troubleshooting guides and frequently asked questions (FAQs) for researchers and scientists working with the experimental compound **PP487**. Our goal is to help you address common issues related to experimental variability and reproducibility.

Frequently Asked Questions (FAQs)

Q1: What is the mechanism of action for **PP487**?

PP487 is a selective inhibitor of the Kinase Associated Protein 6 (KAP6). It functions by competitively binding to the ATP-binding pocket of KAP6, thereby preventing the phosphorylation of its primary downstream target, the Transcription Factor for Cell Survival (TFCS). Inhibition of TFCS phosphorylation leads to the suppression of survival signaling pathways, ultimately inducing apoptosis in susceptible cell lines.

Q2: What are the common sources of variability in cell viability assays (e.g., MTT, CellTiter-Glo) with **PP487**?

High variability in IC50 values for **PP487** is a frequently reported issue. The primary sources of this variability include:

- **Cell Density and Health:** Inconsistent initial cell seeding density and poor cell viability at the time of treatment can significantly alter the apparent efficacy of the compound.
- **Compound Solubility and Stability:** **PP487** has limited aqueous solubility and can precipitate at higher concentrations or after prolonged incubation, reducing its effective concentration.
- **Serum Protein Binding:** Components in fetal bovine serum (FBS) can bind to **PP487**, reducing its bioavailability. Variations in serum batches can lead to inconsistent results.
- **Incubation Time:** The duration of compound exposure can impact the observed IC50 value, with longer incubation times generally resulting in lower values.

Q3: Why am I seeing inconsistent inhibition of p-TFCS in my Western blots?

Inconsistent reduction of phosphorylated TFCS (p-TFCS) levels is often traced back to several key experimental factors:

- **Timing of Lysate Collection:** The peak of TFCS phosphorylation and its subsequent dephosphorylation after **PP487** treatment can be transient. It is critical to perform a time-course experiment to determine the optimal time point for cell lysis after treatment.
- **Lysate Preparation:** Inadequate phosphatase inhibition during lysate preparation can lead to artificial dephosphorylation of TFCS, masking the effect of **PP487**. Always use fresh phosphatase inhibitor cocktails.
- **Antibody Quality:** The specificity and affinity of the primary antibody for p-TFCS are crucial. Ensure the antibody has been validated for the specific application and use it at the recommended dilution.

Q4: I am having difficulty reproducing my Cellular Thermal Shift Assay (CETSA) results for **PP487** target engagement. What could be the cause?

Reproducibility issues in CETSA experiments with **PP487** can arise from:

- **Heating Inconsistency:** Uneven or inaccurate heating of cell lysates can lead to significant variability. Ensure your heating block or thermal cycler provides uniform temperature distribution.
- **Cell Lysis Conditions:** The method of cell lysis (e.g., freeze-thaw cycles, sonication) can impact protein stability and aggregation. It is important to maintain a consistent lysis protocol.
- **Protein Concentration:** Variations in total protein concentration between samples can affect the thermal stability profile. Accurate protein quantification and normalization are essential.

Troubleshooting Guides

Issue 1: High Variability in IC50 Values

If you are observing significant well-to-well or experiment-to-experiment variability in your IC50 measurements for **PP487**, consider the following troubleshooting steps:

Potential Cause	Recommended Solution
Inconsistent Cell Seeding	Use a cell counter to ensure accurate and consistent cell numbers are seeded in each well. Allow cells to adhere and resume logarithmic growth for 24 hours before treatment.
Compound Precipitation	Prepare fresh stock solutions of PP487 in 100% DMSO. When diluting into culture media, ensure the final DMSO concentration is below 0.5% and vortex the solution immediately. Visually inspect for precipitates.
Serum Interaction	Reduce the serum concentration in your culture media during the treatment period, if compatible with your cell line. Alternatively, perform experiments with a single, pre-tested batch of FBS.
Assay Edge Effects	Avoid using the outer wells of microplates, as they are more prone to evaporation and temperature fluctuations. Fill these wells with sterile PBS or media.

Issue 2: Inconsistent Western Blot Results for p-TFCS

For challenges with detecting a consistent decrease in p-TFCS levels following **PP487** treatment, please refer to the following guide:

Potential Cause	Recommended Solution
Suboptimal Lysis Time	Perform a time-course experiment (e.g., 0, 1, 2, 4, 8, 24 hours) to identify the time point of maximal p-TFCS inhibition.
Phosphatase Activity	Prepare lysis buffer immediately before use and include a potent phosphatase inhibitor cocktail. Keep lysates on ice at all times.
Low Signal Intensity	Increase the amount of protein loaded per well. Ensure the transfer to the PVDF or nitrocellulose membrane is efficient. Use a validated and high-affinity primary antibody for p-TFCS.
Loading Control Variability	Use a stable housekeeping protein (e.g., GAPDH, β -actin) as a loading control and normalize the p-TFCS signal to this control.

Experimental Protocols

Standard Protocol for Cell Viability (MTT) Assay

- **Cell Seeding:** Seed cells in a 96-well plate at a density of 5,000-10,000 cells per well in 100 μ L of complete growth medium. Incubate for 24 hours at 37°C and 5% CO₂.
- **Compound Preparation:** Prepare a 2X serial dilution of **PP487** in culture medium. The final DMSO concentration should not exceed 0.5%.
- **Cell Treatment:** Remove the old medium from the cells and add 100 μ L of the **PP487** dilutions or vehicle control. Incubate for 48 hours.
- **MTT Addition:** Add 20 μ L of 5 mg/mL MTT solution to each well and incubate for 4 hours at 37°C.
- **Solubilization:** Carefully remove the medium and add 150 μ L of DMSO to each well to dissolve the formazan crystals.

- Absorbance Measurement: Measure the absorbance at 570 nm using a microplate reader.
- Data Analysis: Normalize the absorbance values to the vehicle control and plot the dose-response curve to calculate the IC50 value.

Standard Protocol for Western Blotting of p-TFCS

- Cell Treatment: Plate cells in a 6-well plate and grow to 70-80% confluency. Treat with the desired concentrations of **PP487** for the predetermined optimal time.
- Cell Lysis: Wash cells with ice-cold PBS and lyse with 100 μ L of RIPA buffer supplemented with protease and phosphatase inhibitor cocktails.
- Protein Quantification: Determine the protein concentration of each lysate using a BCA assay.
- SDS-PAGE: Load 20-30 μ g of protein per lane onto a 10% SDS-polyacrylamide gel. Run the gel until adequate separation is achieved.
- Protein Transfer: Transfer the proteins to a PVDF membrane.
- Blocking: Block the membrane with 5% BSA in TBST for 1 hour at room temperature.
- Primary Antibody Incubation: Incubate the membrane with primary antibodies against p-TFCS (e.g., 1:1000 dilution) and a loading control (e.g., GAPDH, 1:5000) overnight at 4°C.
- Secondary Antibody Incubation: Wash the membrane with TBST and incubate with the appropriate HRP-conjugated secondary antibody for 1 hour at room temperature.
- Detection: Visualize the protein bands using an ECL substrate and an imaging system.
- Analysis: Quantify the band intensities and normalize the p-TFCS signal to the loading control.

Visualizations

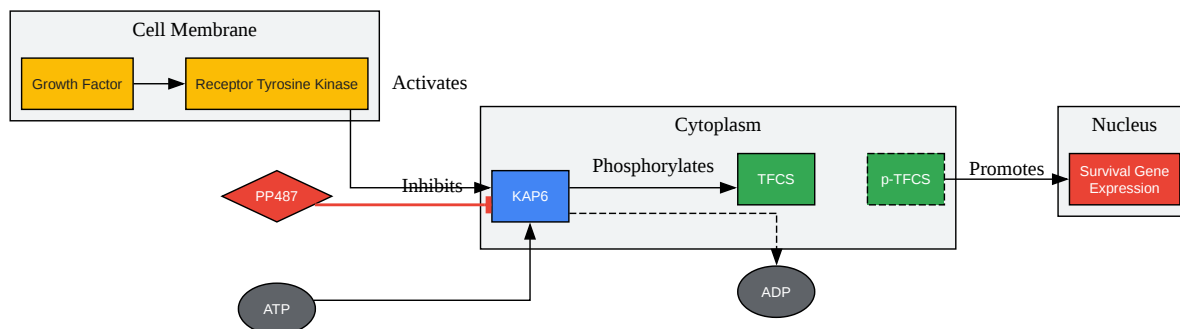

[Click to download full resolution via product page](#)

Caption: Signaling pathway illustrating the inhibitory action of **PP487** on the KAP6-TFCS axis.

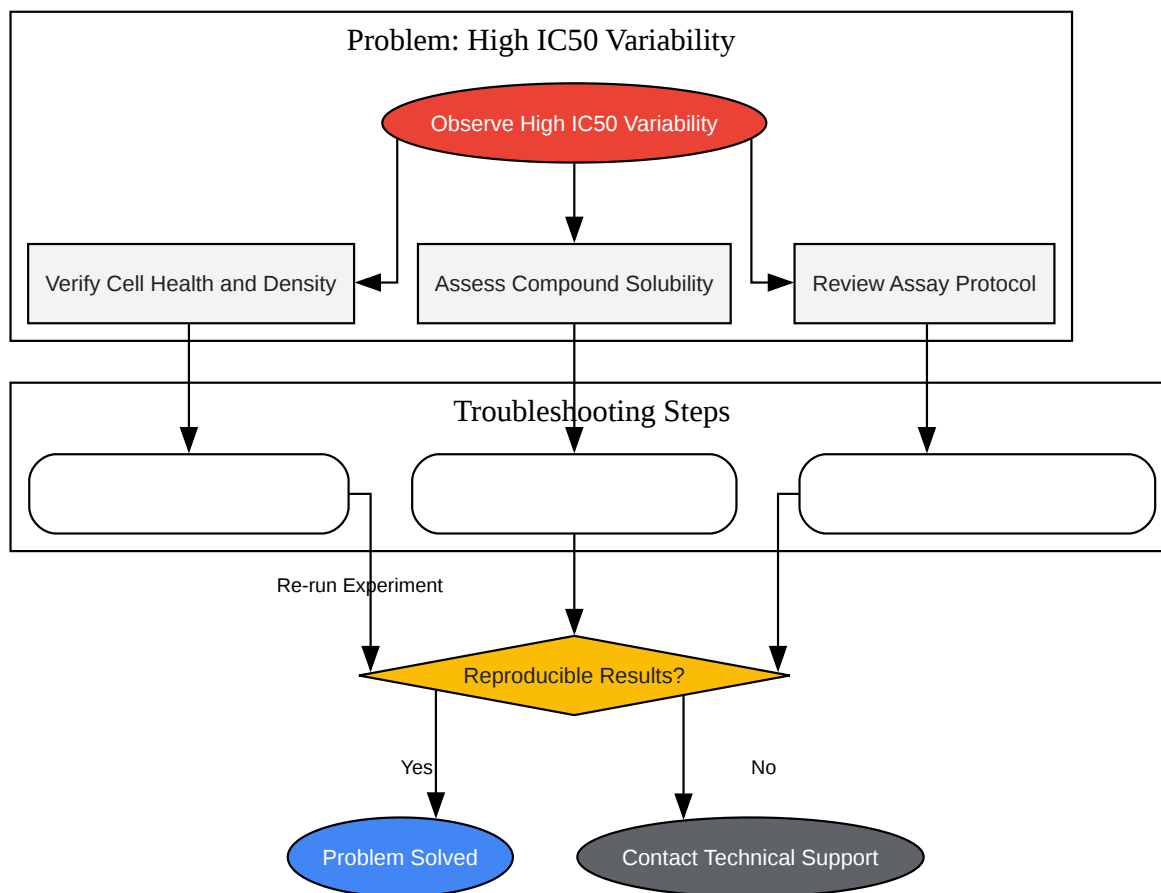

[Click to download full resolution via product page](#)

Caption: Troubleshooting workflow for addressing high variability in **PP487** IC50 values.

- To cite this document: BenchChem. [PP487 experimental variability and reproducibility issues]. BenchChem, [2026]. [Online PDF]. Available at: [\[https://www.benchchem.com/product/b12366087/docs#pp487-experimental-variability-and-reproducibility-issues\]](https://www.benchchem.com/product/b12366087/docs#pp487-experimental-variability-and-reproducibility-issues)

Disclaimer & Data Validity:

The information provided in this document is for Research Use Only (RUO) and is strictly not intended for diagnostic or therapeutic procedures. While BenchChem strives to provide

accurate protocols, we make no warranties, express or implied, regarding the fitness of this product for every specific experimental setup.

Technical Support: The protocols provided are for reference purposes. Unsure if this reagent suits your experiment?

Need Industrial/Bulk Grade? [Request Custom Synthesis Quote](#)

BenchChem

Our mission is to be the trusted global source of essential and advanced chemicals, empowering scientists and researchers to drive progress in science and industry.

Contact

Address: 3281 E Guasti Rd

Ontario, CA 91761, United States

Phone: (601) 213-4426

Email: info@benchchem.com

[Contact our Ph.D. Support Team for a compatibility check](#)