

JNJ-38877605: A Comparative Guide to a Selective c-Met Probe

Author: BenchChem Technical Support Team. **Date:** April 2026

Compound of Interest

Compound Name: JNJ-38877605-d1

Cat. No.: B12366438

[Get Quote](#)

For Researchers, Scientists, and Drug Development Professionals

This guide provides a comprehensive validation of JNJ-38877605 as a selective c-Met probe, offering an objective comparison with alternative inhibitors and supported by experimental data. The information is intended to assist researchers in making informed decisions for their c-Met related studies.

Executive Summary

JNJ-38877605 is a potent and highly selective, ATP-competitive inhibitor of the c-Met receptor tyrosine kinase.^{[1][2][3]} With a reported IC₅₀ of 4 nM, it demonstrates over 600-fold selectivity for c-Met compared to a broad panel of other tyrosine and serine-threonine kinases.^{[1][2]} This high selectivity makes JNJ-38877605 a valuable tool for specifically investigating the biological roles of c-Met in normal physiology and disease. However, it is crucial to note that further clinical development of JNJ-38877605 was halted due to species-specific renal toxicity observed in preclinical and early-phase human trials.^{[4][5]} This guide will delve into the validation data for JNJ-38877605 and compare its performance with other well-established c-Met inhibitors.

Comparative Analysis of c-Met Inhibitors

The following table summarizes the key performance indicators of JNJ-38877605 in comparison to other selective and multi-kinase c-Met inhibitors.

Inhibitor	Type	c-Met IC50 (nM)	Selectivity Profile	Key Features
JNJ-38877605	ATP-competitive	4[1][3]	>600-fold selective for c-Met over 200 other kinases.[1][2]	Potent and highly selective; preclinical development halted due to renal toxicity.[4][5]
Crizotinib	Multi-kinase	8	Also inhibits ALK and ROS1.	FDA-approved for ALK-positive and ROS1-positive NSCLC; also shows efficacy in MET-amplified cancers.[6]
Cabozantinib	Multi-kinase	5.4[7]	Inhibits c-Met, VEGFR2, AXL, RET, KIT, and others.[8][9]	FDA-approved for medullary thyroid cancer, renal cell carcinoma, and hepatocellular carcinoma.[8]
Capmatinib	Selective	0.8	Highly potent and selective MET inhibitor.	FDA-approved for metastatic NSCLC with MET exon 14 skipping mutations.[10]
Tepotinib	Selective	1.1	Highly selective oral MET inhibitor.	FDA-approved for metastatic NSCLC with MET exon 14

				skipping mutations. [11]
Foretinib	Multi-kinase	3.4	Inhibits c-Met and VEGFR2.	Has been evaluated in clinical trials for various cancers. [6]

Experimental Validation of JNJ-38877605

The validation of JNJ-38877605 as a c-Met selective probe involved a series of in vitro and in vivo experiments to determine its potency, selectivity, and cellular effects.

In Vitro Kinase Assay

Objective: To determine the half-maximal inhibitory concentration (IC₅₀) of JNJ-38877605 against c-Met kinase activity.

Methodology:

- Enzyme and Substrate Preparation: Recombinant human c-Met kinase domain and a generic tyrosine kinase substrate (e.g., poly(Glu, Tyr) 4:1) are prepared in a kinase assay buffer.
- Inhibitor Dilution: JNJ-38877605 is serially diluted to a range of concentrations.
- Kinase Reaction: The c-Met enzyme is incubated with the substrate and varying concentrations of JNJ-38877605 in the presence of ATP.
- Detection: The level of substrate phosphorylation is quantified. This can be achieved through various methods, such as radioactive assays (³²P-ATP), ELISA-based methods with phospho-specific antibodies, or luminescence-based assays that measure ATP consumption (e.g., ADP-Glo™).
- Data Analysis: The percentage of kinase inhibition at each drug concentration is calculated relative to a no-inhibitor control. The IC₅₀ value is then determined by fitting the data to a dose-response curve.

Cellular Phosphorylation Assay

Objective: To assess the ability of JNJ-38877605 to inhibit c-Met autophosphorylation in a cellular context.

Methodology:

- **Cell Culture:** A cancer cell line with high c-Met expression (e.g., GTL-16 gastric carcinoma cells) is cultured to sub-confluency.
- **Serum Starvation and Stimulation:** Cells are serum-starved to reduce basal kinase activity and then stimulated with Hepatocyte Growth Factor (HGF) to induce c-Met phosphorylation.
- **Inhibitor Treatment:** Cells are pre-treated with varying concentrations of JNJ-38877605 before HGF stimulation.
- **Cell Lysis and Protein Quantification:** Cells are lysed, and total protein concentration is determined.
- **Western Blot Analysis:** Equal amounts of protein from each treatment condition are separated by SDS-PAGE and transferred to a membrane. The membrane is probed with antibodies specific for phosphorylated c-Met (p-c-Met) and total c-Met.
- **Data Analysis:** The band intensities for p-c-Met are normalized to total c-Met to determine the extent of inhibition at each JNJ-38877605 concentration.

In Vivo Xenograft Model

Objective: To evaluate the anti-tumor efficacy of JNJ-38877605 in a preclinical animal model.

Methodology:

- **Animal Model:** Immunodeficient mice (e.g., nu/nu female mice) are used.[\[1\]](#)
- **Tumor Implantation:** Cancer cells with high c-Met expression (e.g., GTL-16 or U251 glioblastoma cells) are subcutaneously injected into the flanks of the mice.[\[1\]](#)[\[2\]](#)

- **Tumor Growth and Treatment:** Once tumors reach a palpable size, mice are randomized into control and treatment groups. JNJ-38877605 is administered orally at a specified dose and schedule (e.g., 40-50 mg/kg/day).^{[1][2]}
- **Tumor Measurement:** Tumor volume is measured regularly using calipers.
- **Pharmacodynamic Analysis:** At the end of the study, tumors can be excised to assess the level of c-Met phosphorylation by western blot or immunohistochemistry to confirm target engagement.
- **Data Analysis:** Tumor growth curves are plotted for each group, and statistical analysis is performed to determine the significance of tumor growth inhibition by JNJ-38877605 compared to the control group.

Visualizing the c-Met Signaling Pathway and Experimental Workflows

To further illustrate the context of JNJ-38877605's mechanism and validation, the following diagrams are provided.

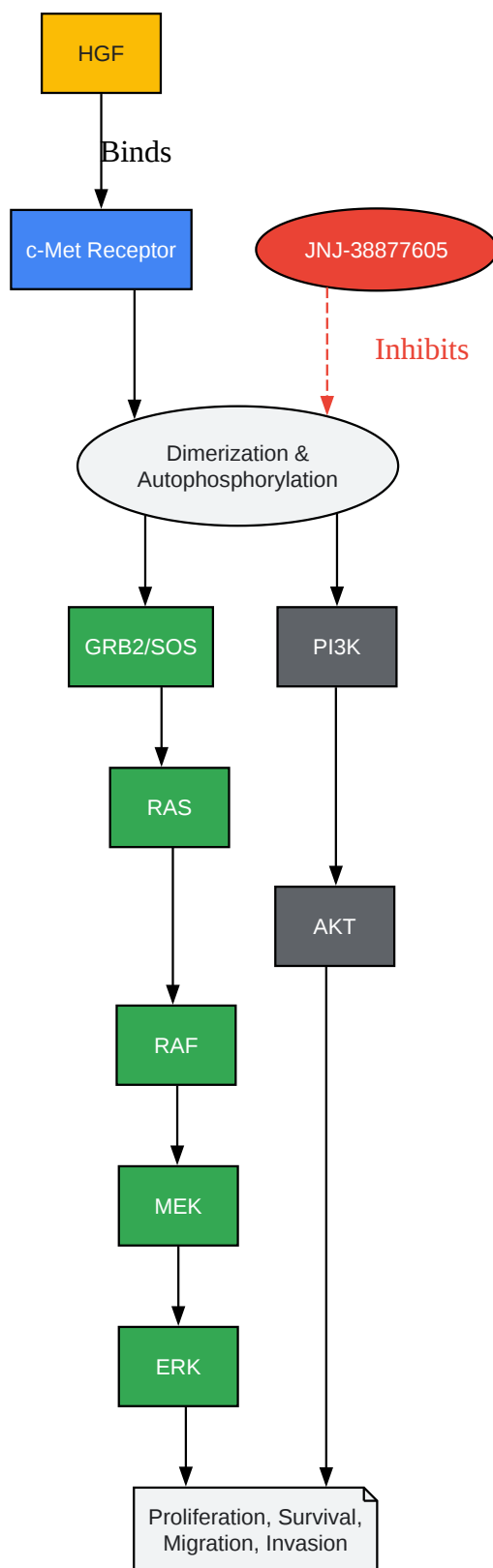

[Click to download full resolution via product page](#)

Caption: The c-Met signaling pathway and the inhibitory action of JNJ-38877605.

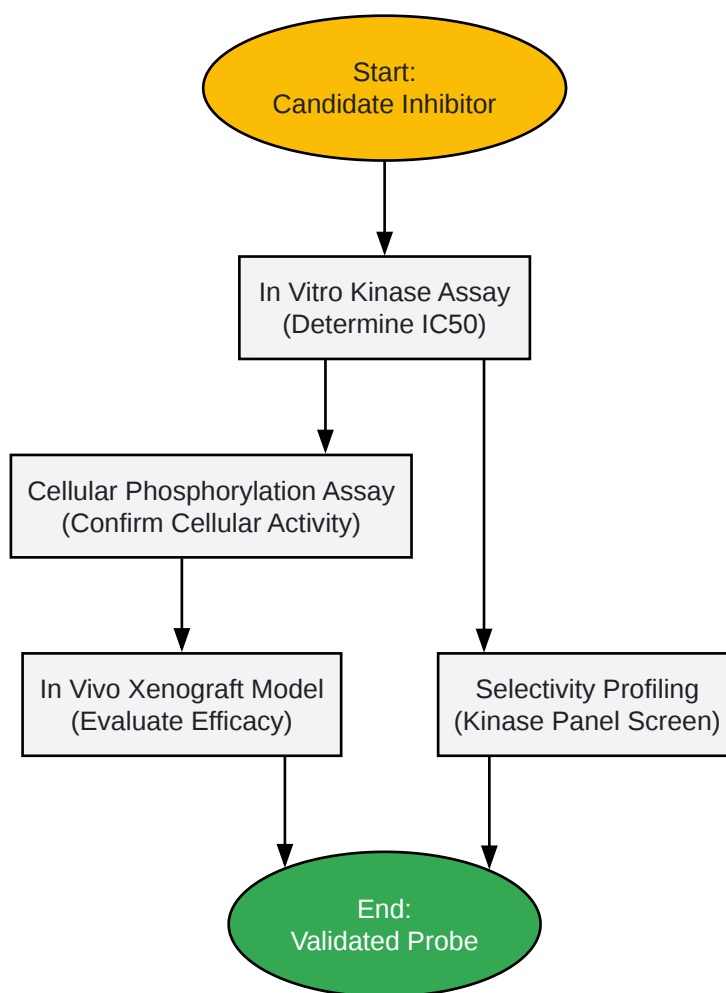

[Click to download full resolution via product page](#)

Caption: A generalized workflow for the validation of a selective kinase inhibitor.

Conclusion

JNJ-38877605 stands out as a highly potent and selective c-Met inhibitor, making it an excellent chemical probe for dissecting c-Met signaling in vitro and in preclinical in vivo models. Its well-defined inhibitory profile allows for confident attribution of observed biological effects to the specific inhibition of c-Met. However, its known species-specific renal toxicity precludes its use in clinical settings. For translational research aiming for clinical application, alternative c-Met inhibitors such as Capmatinib or Tepotinib, which have gained regulatory approval, would be more appropriate choices. Researchers should carefully consider the specific goals of their study when selecting a c-Met inhibitor, weighing the high selectivity of probes like JNJ-38877605 against the clinical relevance of approved drugs.

Need Custom Synthesis?

BenchChem offers custom synthesis for rare earth carbides and specific isotopic labeling.

Email: info@benchchem.com or [Request Quote Online](#).

References

- [1. selleckchem.com](https://www.selleckchem.com) [selleckchem.com]
- [2. cancer-research-network.com](https://www.cancer-research-network.com) [cancer-research-network.com]
- [3. medchemexpress.com](https://www.medchemexpress.com) [medchemexpress.com]
- [4. The c-Met tyrosine kinase inhibitor JNJ-38877605 causes renal toxicity through species specific insoluble metabolite formation - PMC](#) [pmc.ncbi.nlm.nih.gov]
- [5. The c-Met Tyrosine Kinase Inhibitor JNJ-38877605 Causes Renal Toxicity through Species-Specific Insoluble Metabolite Formation - PubMed](#) [pubmed.ncbi.nlm.nih.gov]
- [6. c-Met inhibitor - Wikipedia](#) [en.wikipedia.org]
- [7. researchgate.net](https://www.researchgate.net) [researchgate.net]
- [8. Targeting of c-MET and AXL by cabozantinib is a potential therapeutic strategy for patients with head and neck cell carcinoma - PMC](#) [pmc.ncbi.nlm.nih.gov]
- [9. cabometyxhcp.com](https://www.cabometyxhcp.com) [cabometyxhcp.com]
- [10. cancernetwork.com](https://www.cancernetwork.com) [cancernetwork.com]
- [11. targetedonc.com](https://www.targetedonc.com) [targetedonc.com]
- To cite this document: BenchChem. [JNJ-38877605: A Comparative Guide to a Selective c-Met Probe]. BenchChem, [2026]. [Online PDF]. Available at: [https://www.benchchem.com/product/b12366438/docs#jnj-38877605-a-comparative-guide-to-a-selective-c-met-probe]

Disclaimer & Data Validity:

The information provided in this document is for Research Use Only (RUO) and is strictly not intended for diagnostic or therapeutic procedures. While BenchChem strives to provide accurate protocols, we make no warranties, express or implied, regarding the fitness of this product for every specific experimental setup.

Technical Support: The protocols provided are for reference purposes. Unsure if this reagent suits your experiment?

Need Industrial/Bulk Grade? [Request Custom Synthesis Quote](#)

BenchChem

Our mission is to be the trusted global source of essential and advanced chemicals, empowering scientists and researchers to drive progress in science and industry.

Contact

Address: 3281 E Guasti Rd
Ontario, CA 91761, United States
Phone: (601) 213-4426
Email: info@benchchem.com

[Contact our Ph.D. Support Team for a compatibility check](#)