

# GluN2B subunit selectivity of NMDA receptor modulator 8

**Author:** BenchChem Technical Support Team. **Date:** April 2026

## Compound of Interest

Compound Name: NMDA receptor modulator 8

Cat. No.: B12366913

[Get Quote](#)

## Introduction: The NMDA Receptor and the GluN2B Subunit

NMDA receptors are ionotropic glutamate receptors that function as ligand-gated ion channels. [4] For activation, they uniquely require the binding of two co-agonists, glutamate and glycine, as well as the relief of a voltage-dependent magnesium ( $Mg^{2+}$ ) block through membrane depolarization. [5] Structurally, they are heterotetrameric complexes, typically composed of two obligatory GluN1 subunits and two variable GluN2 subunits (GluN2A, GluN2B, GluN2C, or GluN2D). [5][6]

The specific GluN2 subunit incorporated into the receptor complex dictates its pharmacological and biophysical properties, including agonist affinity, deactivation kinetics, and channel conductance. [7] The GluN2B subunit is highly expressed in the forebrain and is associated with critical physiological processes but also with pathological pro-death signaling pathways when overactivated. [1] Consequently, developing subunit-selective antagonists that target GluN2B-containing receptors is a promising strategy for neuroprotection with potentially fewer side effects than non-selective NMDA receptor blockers. [4][8]

## Overview of Modulator 8 (Compound (R)-10a)

**NMDA Receptor Modulator 8** (hereafter referred to as Modulator 8) is the (R)-enantiomer of 3-(4-benzylpiperidin-1-yl)-1-(1H-indazol-5-yl)propan-1-ol, designated (R)-10a in the primary literature.<sup>[2][3]</sup> It was developed as a bioisosteric replacement for the phenol group found in many prominent GluN2B antagonists like ifenprodil.<sup>[2][3]</sup> This modification was designed to retain high GluN2B affinity while preventing the rapid glucuronidation that affects phenolic compounds, thereby improving metabolic stability.<sup>[2][3]</sup>

## Pharmacological Profile and Selectivity

The defining characteristic of Modulator 8 is its potent and selective inhibition of GluN2B-containing NMDA receptors. Its pharmacological activity has been quantified through radioligand binding assays and functional electrophysiological studies.

### Binding Affinity ( $K_i$ )

Binding affinity was determined via competitive radioligand binding assays against various receptors to assess both potency and selectivity. The data show high affinity for the GluN2B receptor's ifenprodil binding site, with off-target activity primarily noted at sigma ( $\sigma$ ) receptors.

Target Receptor	Radioligand	$K_i$ (nM)	Source
NMDA (GluN2B site)	[ <sup>3</sup> H]ifenprodil	265	[9]
Sigma-1 ( $\sigma_1$ )	(+)-[ <sup>3</sup> H]pentazocine	Data indicates limited selectivity	[2][3]
Sigma-2 ( $\sigma_2$ )	[ <sup>3</sup> H]ditolylguanidine	Data indicates limited selectivity	[2][3]

Note: Specific  $K_i$  values for sigma receptors were not available in the cited abstracts, but the primary literature indicates limited selectivity, suggesting binding in a similar range to GluN2B.<sup>[2][3]</sup>

### Functional Inhibition ( $IC_{50}$ )

The functional inhibitory activity of Modulator 8 was assessed using two-electrode voltage-clamp (TEVC) electrophysiology on *Xenopus* oocytes expressing specific NMDA receptor subtypes. Modulator 8 demonstrates potent, voltage-independent inhibition of GluN2B-containing receptors.

Receptor Subtype	Agonists	IC <sub>50</sub> (nM)	Source
GluN1/GluN2B	Glutamate/Glycine	62	[9]
GluN1/GluN2A	Glutamate/Glycine	>10,000	Inferred from high selectivity

Note: The primary literature states that (R)-10a displayed higher inhibitory activity than ifenprodil.[2][3]

## Mechanism of Action

Modulator 8 acts as a negative allosteric modulator (NAM).[2][3] Unlike competitive antagonists that bind directly to the glutamate or glycine sites, Modulator 8 binds to a distinct, allosteric site located at the interface between the amino-terminal domains (ATDs) of the GluN1 and GluN2B subunits.[2][3][10] This is the well-characterized "ifenprodil pocket." Binding to this site stabilizes a non-active conformation of the receptor, which reduces the probability of the ion channel opening even when the co-agonists glutamate and glycine are bound.[11] This results in a non-competitive and use-dependent inhibition of receptor function.

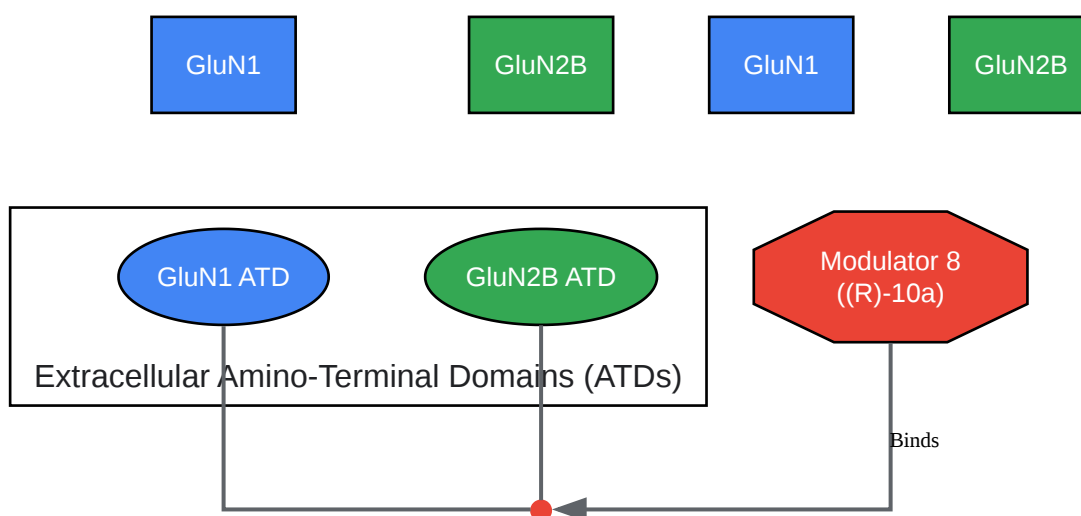

Figure 1: NMDA Receptor Structure and Modulator 8 Binding Site

[Click to download full resolution via product page](#)

Figure 1: NMDA Receptor Structure and Modulator 8 Binding Site

## Detailed Experimental Protocols

The following sections describe the standard methodologies for determining the binding affinity and functional potency of GluN2B-selective modulators.

### Radioligand Competition Binding Assay (for $K_i$ Determination)

This assay quantifies the affinity of a test compound by measuring its ability to displace a known radiolabeled ligand from the receptor.

#### 1. Membrane Preparation:

- Brain tissue from a region rich in GluN2B receptors (e.g., porcine hippocampus) or membranes from cells heterologously expressing GluN1/GluN2B subunits are used.[12]
- Tissue is homogenized in a cold lysis buffer (e.g., 50mM Tris-HCl, pH 7.4) with protease inhibitors.[9]
- The homogenate is centrifuged to pellet the membranes, which are then washed and resuspended in a suitable buffer.[9] Protein concentration is determined using a standard assay (e.g., BCA).[9]

#### 2. Assay Procedure:

- The assay is performed in a 96-well plate format.[9]
- To each well, add:
  - The membrane preparation.
  - A fixed concentration of a selective GluN2B radioligand, typically [ $^3$ H]ifenprodil (e.g., 4-5 nM).[13]

- Varying concentrations of the unlabeled test compound (Modulator 8).
- Control wells are included for total binding (no competitor) and non-specific binding (a high concentration of a known non-radioactive ligand, e.g., 100  $\mu$ M CP-101,606).[13]
- Plates are incubated (e.g., 60 minutes at 25-30°C) to reach binding equilibrium.[9][13]

### 3. Data Acquisition and Analysis:

- The reaction is terminated by rapid vacuum filtration through glass fiber filters (e.g., GF/C), which traps the membranes while allowing unbound radioligand to pass through.[1][9]
- Filters are washed with ice-cold buffer to remove any remaining unbound radioligand.[9]
- The radioactivity retained on the filters is quantified using a scintillation counter.[9]
- Specific binding is calculated by subtracting non-specific binding from total binding. The data are plotted as percent specific binding versus log concentration of the competitor, and an  $IC_{50}$  value (the concentration of competitor that displaces 50% of the radioligand) is determined using non-linear regression.
- The  $K_i$  value is then calculated from the  $IC_{50}$  using the Cheng-Prusoff equation:  $K_i = IC_{50} / (1 + [L]/K_e)$ , where [L] is the concentration of the radioligand and  $K_e$  is its dissociation constant.  
[9]

## Two-Electrode Voltage Clamp (TEVC) Electrophysiology (for $IC_{50}$ Determination)

TEVC is a powerful technique for studying ion channels expressed in large cells, such as *Xenopus laevis* oocytes, allowing for precise control of membrane potential and measurement of ion currents.[14][15]

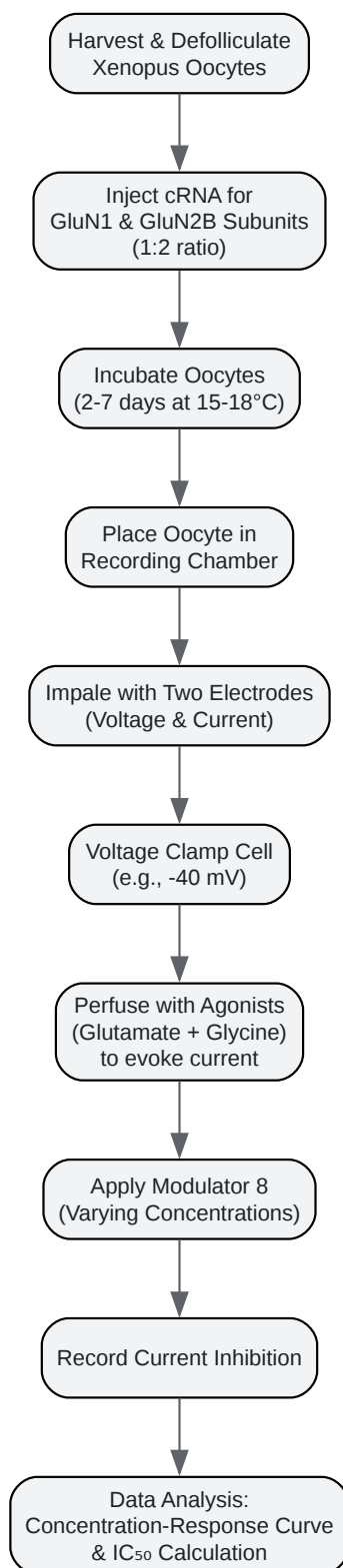

Figure 2: Experimental Workflow for TEVC Assay

[Click to download full resolution via product page](#)

Figure 2: Experimental Workflow for TEVC Assay

### 1. Oocyte Preparation:

- Stage V-VI oocytes are harvested from *Xenopus laevis* frogs.[16]
- Oocytes are injected with complementary RNA (cRNA) encoding the desired NMDA receptor subunits (e.g., human GluN1 and GluN2B) in a 1:2 ratio.[16]
- Injected oocytes are incubated for 2-7 days in a culture medium (e.g., Barth's solution) to allow for receptor expression on the cell membrane.[16]

### 2. Recording Setup:

- An oocyte is placed in a recording chamber and continuously perfused with an extracellular recording solution (e.g., containing NaCl, KCl, HEPES, and BaCl<sub>2</sub> instead of CaCl<sub>2</sub> to avoid activating calcium-dependent chloride channels).[16]
- Two glass microelectrodes, filled with a conductive solution (e.g., 3M KCl), are impaled into the oocyte.[14] One electrode measures the membrane potential, while the other injects current to clamp the potential at a set holding value (e.g., -40 mV).[16]

### 3. Data Acquisition:

- The baseline current is recorded.
- A solution containing saturating concentrations of co-agonists (e.g., 100 μM glutamate and 30 μM glycine) is perfused to evoke a maximal NMDA receptor-mediated inward current.
- Once a stable current is achieved, the test compound (Modulator 8) is co-applied with the agonists at increasing concentrations.
- The degree of current inhibition is measured at each concentration of Modulator 8.

### 4. Data Analysis:

- The inhibitory effect at each concentration is expressed as a percentage of the maximal agonist-evoked current.

- A concentration-response curve is generated by plotting the percent inhibition against the log concentration of Modulator 8.
- The IC<sub>50</sub> value is determined by fitting the data with a sigmoidal dose-response function.

## Signaling Context

NMDA receptor activation initiates a cascade of intracellular signaling events, primarily driven by calcium (Ca<sup>2+</sup>) influx. Modulator 8 interrupts the initial step of this cascade.

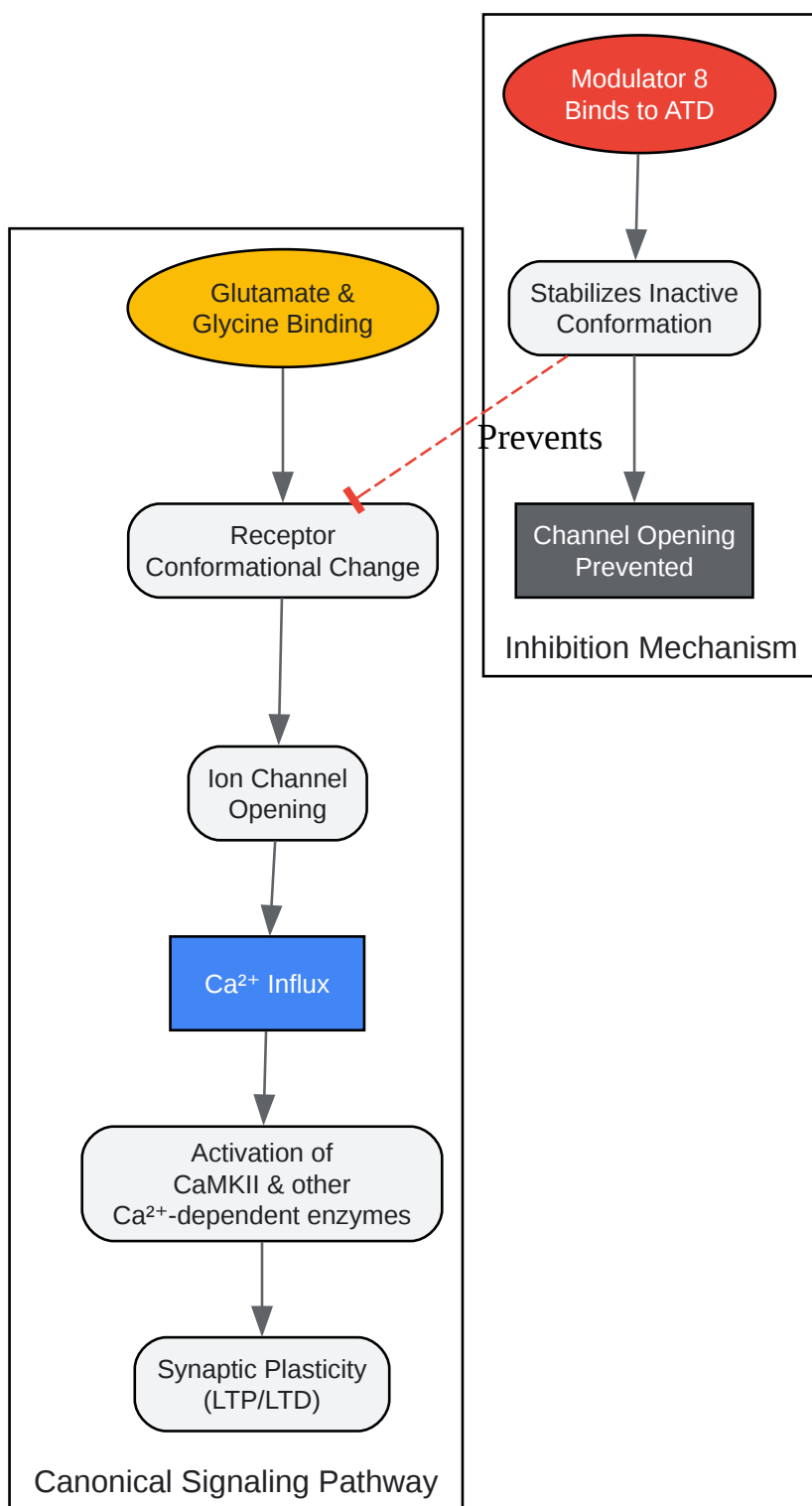

Figure 3: NMDA Receptor Signaling and Inhibition by Modulator 8

[Click to download full resolution via product page](#)

Figure 3: NMDA Receptor Signaling and Inhibition by Modulator 8

As shown in Figure 3, the binding of Modulator 8 to the GluN1/GluN2B ATD interface prevents the conformational change required for channel gating. This blockade of Ca<sup>2+</sup> influx effectively uncouples receptor activation from its downstream signaling pathways, which include the activation of calcium/calmodulin-dependent protein kinase II (CaMKII) and other effectors that regulate synaptic strength and neuronal viability.

## Conclusion

**NMDA Receptor Modulator 8** (Compound (R)-10a) is a potent and selective negative allosteric modulator of NMDA receptors containing the GluN2B subunit. Its indazole structure represents a successful bioisosteric modification to improve metabolic stability while retaining high affinity and functional inhibitory activity.[2][3] The detailed pharmacological profile and clear mechanism of action make it a valuable tool for probing the physiological and pathological roles of GluN2B-containing NMDA receptors. Furthermore, its properties position it as a promising lead scaffold for the development of novel neurotherapeutics targeting a range of CNS disorders characterized by NMDA receptor hyperactivity.

### *Need Custom Synthesis?*

*BenchChem offers custom synthesis for rare earth carbides and specific isotopic labeling.*

*Email: [info@benchchem.com](mailto:info@benchchem.com) or [Request Quote Online](#).*

## References

- [1. europeanpharmaceuticalreview.com \[europeanpharmaceuticalreview.com\]](http://europeanpharmaceuticalreview.com)
- [2. Indazole as a Phenol Bioisostere: Structure-Affinity Relationships of GluN2B-Selective NMDA Receptor Antagonists - PubMed \[pubmed.ncbi.nlm.nih.gov\]](https://pubmed.ncbi.nlm.nih.gov/)
- [3. pubs.acs.org \[pubs.acs.org\]](https://pubs.acs.org)
- [4. mdpi.com \[mdpi.com\]](https://mdpi.com)
- [5. selleckchem.com \[selleckchem.com\]](https://selleckchem.com)
- [6. Pharmacology of NMDA Receptors - Biology of the NMDA Receptor - NCBI Bookshelf \[ncbi.nlm.nih.gov\]](https://ncbi.nlm.nih.gov/)
- [7. Phenol-benzoxazolone bioisosteres of GluN2B-NMDA receptor antagonists: Unexpected rearrangement during reductive alkylation with phenylcyclohexanone - PubMed](https://pubmed.ncbi.nlm.nih.gov/)

[\[pubmed.ncbi.nlm.nih.gov\]](https://pubmed.ncbi.nlm.nih.gov)

- [8. giffordbioscience.com \[giffordbioscience.com\]](https://giffordbioscience.com)
- [9. NMDA receptor antagonist - Wikipedia \[en.wikipedia.org\]](https://en.wikipedia.org)
- [10. researchgate.net \[researchgate.net\]](https://researchgate.net)
- [11. pdspdb.unc.edu \[pdspdb.unc.edu\]](https://pdspdb.unc.edu)
- [12. Development and Validation of \[3H\]OF-NB1 for Preclinical Assessment of GluN1/2B Candidate Drugs - PMC \[pmc.ncbi.nlm.nih.gov\]](https://pubmed.ncbi.nlm.nih.gov)
- [13. researchgate.net \[researchgate.net\]](https://researchgate.net)
- [14. Two-electrode voltage clamp - PubMed \[pubmed.ncbi.nlm.nih.gov\]](https://pubmed.ncbi.nlm.nih.gov)
- [15. Two electrode voltage clamp recordings from Xenopus oocytes \[bio-protocol.org\]](https://bio-protocol.org)
- [16. npi's guide to Two Electrode Voltage Clamp in Xenopus oocytes - NPI Electronic \[npielectronic.com\]](https://npielectronic.com)
- To cite this document: BenchChem. [GluN2B subunit selectivity of NMDA receptor modulator 8]. BenchChem, [2026]. [Online PDF]. Available at: [\[https://www.benchchem.com/product/b12366913/docs#glun2b-subunit-selectivity-of-nmda-receptor-modulator-8\]](https://www.benchchem.com/product/b12366913/docs#glun2b-subunit-selectivity-of-nmda-receptor-modulator-8)

---

### Disclaimer & Data Validity:

The information provided in this document is for Research Use Only (RUO) and is strictly not intended for diagnostic or therapeutic procedures. While BenchChem strives to provide accurate protocols, we make no warranties, express or implied, regarding the fitness of this product for every specific experimental setup.

**Technical Support:** The protocols provided are for reference purposes. Unsure if this reagent suits your experiment?

**Need Industrial/Bulk Grade?** [Request Custom Synthesis Quote](#)

# BenchChem

Our mission is to be the trusted global source of essential and advanced chemicals, empowering scientists and researchers to drive progress in science and industry.

## Contact

Address: 3281 E Guasti Rd

Ontario, CA 91761, United States

Phone: (601) 213-4426

Email: [info@benchchem.com](mailto:info@benchchem.com)

[Contact our Ph.D. Support Team for a compatibility check](#)