

Crystal Structure of PCSK9 with Small Molecule Ligands: An In-depth Technical Guide

Author: BenchChem Technical Support Team. **Date:** April 2026

Compound of Interest

Compound Name: *(R,R)*-PCSK9 degrader 1

Cat. No.: B12366527

[Get Quote](#)

For Researchers, Scientists, and Drug Development Professionals

Executive Summary

Proprotein Convertase Subtilisin/Kexin type 9 (PCSK9) is a key regulator of plasma cholesterol levels, making it a prime target for the development of therapeutics to treat hypercholesterolemia and reduce the risk of cardiovascular disease. While monoclonal antibodies targeting PCSK9 have proven effective, the pursuit of orally bioavailable small molecule inhibitors remains a significant endeavor in drug discovery. Understanding the structural basis of PCSK9 interaction with small molecule ligands is paramount for the rational design of potent and selective inhibitors. This technical guide provides a comprehensive overview of the crystal structures of PCSK9 in complex with small molecule ligands, presenting key quantitative data, detailed experimental methodologies, and visual representations of relevant biological and experimental workflows.

The PCSK9-LDLR Signaling Pathway

PCSK9 functions by binding to the Low-Density Lipoprotein Receptor (LDLR) on the surface of hepatocytes. This interaction targets the LDLR for lysosomal degradation, thereby reducing the number of receptors available to clear LDL cholesterol from the bloodstream. Small molecule

inhibitors aim to disrupt this protein-protein interaction, allowing for the recycling of LDLR to the cell surface and subsequent reduction in circulating LDL cholesterol.

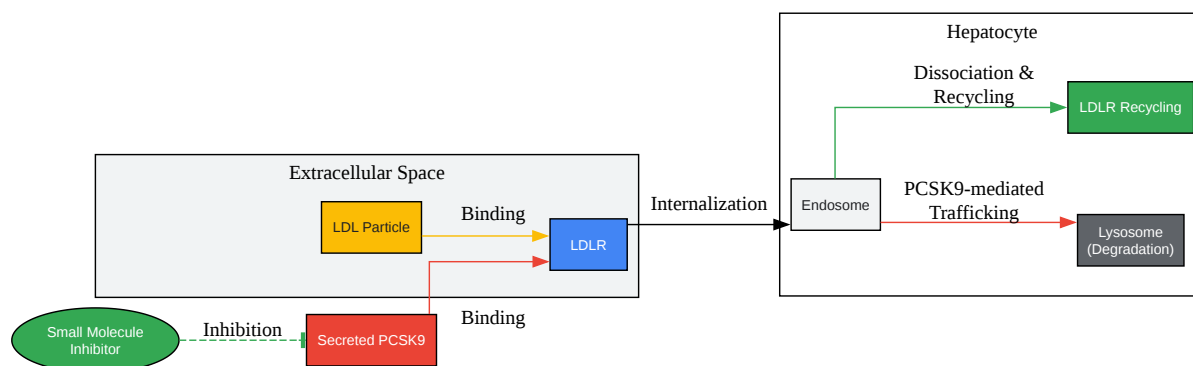

[Click to download full resolution via product page](#)

PCSK9-LDLR signaling and inhibition.

Quantitative Data: Co-crystal Structures and Binding Affinities

The following tables summarize key crystallographic data for PCSK9 in complex with small molecule ligands and the corresponding binding affinities where available. This data provides a quantitative basis for comparing different inhibitor scaffolds and their interactions with the target protein.

Table 1: Crystallographic Data for PCSK9 in Complex with Small Molecule Ligands

PDB ID	Ligand/Inhibitor	Resolution (Å)	R-Value Work	R-Value Free
6U26	Compound 16	1.53	0.187	0.213
8FVL	Synthetic Peptide	1.96	0.193	0.218
2P4E	Mercury Ion	1.98	0.200	0.250
6U2P	Compound 5	2.04	0.183	0.216
6U2N	Compound 4	2.15	0.190	0.234
3H42	Fab from LDLR competitive antibody	2.30	0.191	0.209
7KFA	13mer cyclic peptide	2.45	0.189	0.242
6U3X	Compound 2	2.64	0.248	0.284
6U38	Compound 8	2.73	0.227	0.243
6U3I	Organo-peptide	2.90	0.179	0.217
6U2F	Organo-peptide	2.94	0.174	0.209

Data sourced from the RCSB PDB database.[\[1\]](#)[\[2\]](#)[\[3\]](#)[\[4\]](#)[\[5\]](#)

Table 2: Binding Affinities of Small Molecule Inhibitors for PCSK9

Compound	Assay Type	Affinity Metric	Value	Reference
Nilotinib	In vitro PCSK9-LDLR binding assay	IC50	9.8 μ M	[6]
Compound 13	Not specified	Kd	2.50 μ M	[7]
Pep2-8 (peptide)	Not specified	Kd	0.7 μ M	[7]
(S)-canadine	Molecular Docking	Binding Energy	-9.8 kcal/mol	[8][9]
Hesperetin	Molecular Docking	Binding Energy	-9.2 kcal/mol	[8]
Labetalol	Molecular Docking	Binding Energy	-8.9 kcal/mol	[8]
ZINC000051951669	Molecular Docking	Binding Affinity	-13.2 kcal/mol	[10]
ZINC000011726230	Molecular Docking	Binding Affinity	-11.4 kcal/mol	[10]
SBC	Binding Free Energy Calculation	Δ G	-11.28 kcal/mol	[7]
AK	Binding Free Energy Calculation	Δ G	-5.77 kcal/mol	[7]
RIm	Binding Free Energy Calculation	Δ G	-3.39 kcal/mol	[7]
Amikacin, Bestatin, Natamycin	MM-GBSA	Δ G _{bind}	-76.39 to -84.22 kcal/mol	[11]

Experimental Protocols

Detailed methodologies are crucial for the replication and validation of experimental findings. Below are generalized protocols for key experiments in the study of PCSK9 small molecule inhibitors.

Recombinant PCSK9 Expression and Purification

- **Expression:** Human PCSK9 (e.g., residues 31-692) with a C-terminal His-tag is commonly expressed in human embryonic kidney (HEK293) cells.^{[12][13][14][15]} The DNA sequence encoding the desired construct is transfected into the cells.
- **Cell Culture and Protein Secretion:** Transfected HEK293 cells are cultured in a suitable medium. The recombinant PCSK9 protein is secreted into the culture medium.
- **Harvesting:** The culture supernatant containing the secreted PCSK9 is harvested.
- **Purification:** The harvested supernatant is subjected to affinity chromatography using a nickel-nitrilotriacetic acid (Ni-NTA) resin, which binds the His-tagged PCSK9.
- **Elution:** The bound PCSK9 is eluted from the column using a buffer containing imidazole.
- **Purity and Concentration:** The purity of the eluted protein is assessed by SDS-PAGE, and the protein concentration is determined using a standard protein assay (e.g., BCA assay). The purified protein is typically stored at -80°C in a buffer containing glycerol.^[12]

Co-crystallization of PCSK9 with Small Molecule Ligands

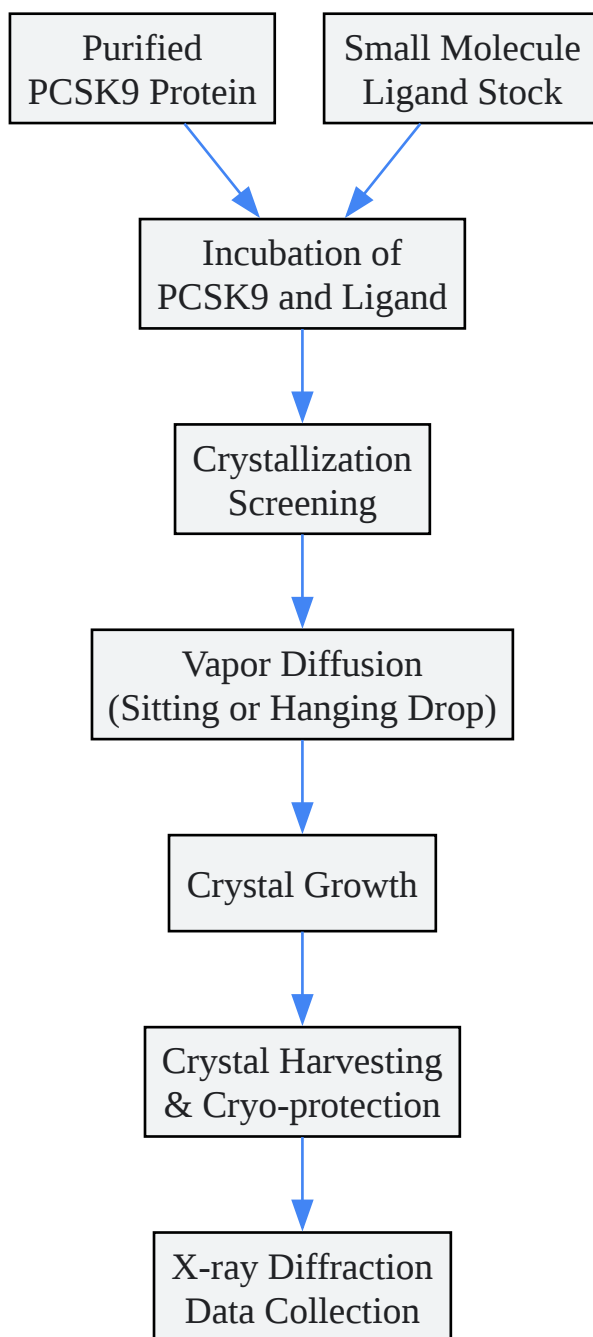

[Click to download full resolution via product page](#)

Workflow for PCSK9 co-crystallization.

- Protein and Ligand Preparation: Purified recombinant PCSK9 is concentrated to a suitable concentration (e.g., 10 mg/mL). The small molecule inhibitor is dissolved in a suitable solvent (e.g., DMSO) to create a stock solution.

- **Complex Formation:** The purified PCSK9 is incubated with an excess of the small molecule inhibitor to ensure saturation of the binding site.
- **Crystallization Screening:** The PCSK9-ligand complex is subjected to high-throughput crystallization screening using various commercially available or custom-made screens that vary in pH, precipitant type, and concentration.
- **Crystal Growth:** Crystallization is typically performed using the vapor diffusion method (sitting or hanging drop) at a controlled temperature (e.g., 4°C or 20°C).
- **Crystal Optimization:** Initial crystal hits are optimized by refining the conditions (e.g., protein concentration, ligand concentration, precipitant concentration, pH) to obtain diffraction-quality crystals.
- **Crystal Harvesting and Cryo-protection:** Crystals are carefully harvested from the drops and soaked in a cryoprotectant solution (e.g., mother liquor supplemented with glycerol or ethylene glycol) before being flash-cooled in liquid nitrogen.

X-ray Diffraction Data Collection and Structure Determination

- **Data Collection:** Diffraction data are collected from the cryo-cooled crystals at a synchrotron radiation source.
- **Data Processing:** The diffraction images are processed to integrate the reflection intensities and scale the data.
- **Structure Solution:** The crystal structure is solved using molecular replacement, with a previously determined structure of PCSK9 as the search model.
- **Model Building and Refinement:** The initial model is refined against the experimental data, and the small molecule ligand is manually built into the electron density map. Iterative cycles of model building and refinement are performed until the model converges and has good stereochemistry.

In Vitro PCSK9-LDLR Binding Assay (ELISA-based)

- **Plate Coating:** A 96-well microplate is coated with the recombinant LDLR ectodomain (e.g., 1-5 µg/mL in PBS) and incubated overnight at 4°C.[16][17][18][19][20]
- **Blocking:** The plate is washed and then blocked with a blocking buffer (e.g., 3% BSA in PBS) for 1-2 hours at room temperature to prevent non-specific binding.[16]
- **Inhibitor Incubation:** Serial dilutions of the small molecule inhibitor are prepared. In a separate plate, the inhibitor is pre-incubated with a fixed concentration of biotinylated or His-tagged recombinant human PCSK9 for 1 hour at room temperature.[21]
- **Binding Reaction:** The inhibitor-PCSK9 mixture is transferred to the LDLR-coated plate and incubated for 2 hours at 37°C.[16]
- **Detection:** The plate is washed, and a detection reagent is added. For biotinylated PCSK9, Streptavidin-HRP is used. For His-tagged PCSK9, an anti-His-HRP antibody is used. The plate is incubated for 1 hour at room temperature.[16][17][18][19]
- **Signal Development:** After another wash step, a chromogenic substrate (e.g., TMB) is added. The reaction is stopped with a stop solution.[16][21]
- **Data Analysis:** The absorbance is read at 450 nm. The percentage of inhibition is calculated for each inhibitor concentration, and the IC50 value is determined by fitting the data to a dose-response curve.[21]

Cell-based LDL Uptake Assay

- **Cell Seeding:** Human hepatoma cells (e.g., HepG2) are seeded in a 96-well plate and allowed to adhere for 24 hours.[22][23][24][25]
- **Compound and PCSK9 Treatment:** The culture medium is replaced with serum-free medium containing serial dilutions of the small molecule inhibitor and a fixed concentration of recombinant PCSK9 (e.g., 1 µg/mL).[22][24] The cells are incubated for 16-24 hours.[22][24]
- **LDL Uptake:** Fluorescently labeled LDL (e.g., BODIPY-LDL or DiI-LDL) is added to the wells, and the cells are incubated for an additional 2-4 hours to allow for LDL uptake.[21][22][24]

- **Washing and Imaging:** The cells are washed with PBS to remove unbound fluorescent LDL. The cellular fluorescence is then quantified using a fluorescence microscope or a plate reader.[\[22\]](#)[\[24\]](#)
- **Data Analysis:** The fluorescence intensity is normalized to the number of cells. The ability of the inhibitor to rescue LDL uptake in the presence of PCSK9 is calculated, and an EC50 value is determined.

Structure-Based Drug Design of PCSK9 Inhibitors

The availability of co-crystal structures of PCSK9 with small molecule inhibitors has been instrumental in guiding structure-based drug design efforts. A typical workflow involves a cyclical process of design, synthesis, and testing to optimize inhibitor potency and drug-like properties.

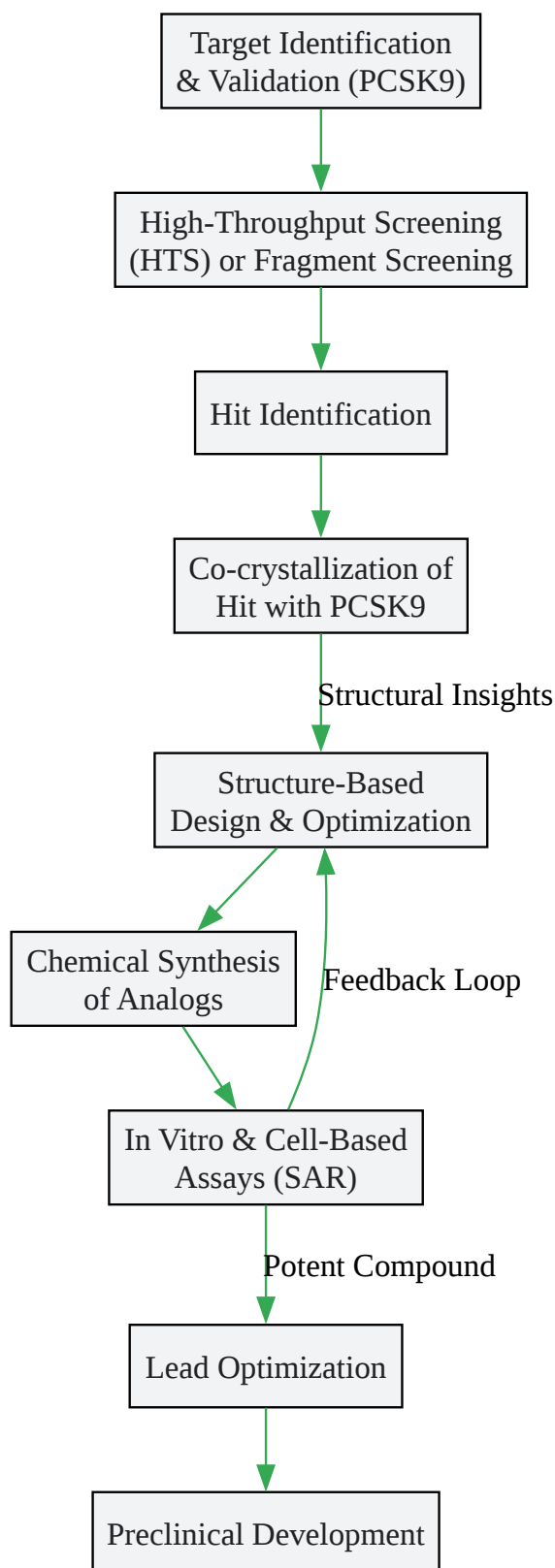

[Click to download full resolution via product page](#)

Structure-based drug design workflow.

Conclusion

The determination of the crystal structure of PCSK9 in complex with small molecule ligands has provided invaluable insights into the molecular interactions that can be exploited for the design of novel therapeutics for hypercholesterolemia. The data and protocols presented in this guide serve as a foundational resource for researchers in the field, facilitating the continued development of potent, selective, and orally bioavailable small molecule inhibitors of PCSK9. The iterative process of structure-based drug design, informed by high-resolution crystal structures and robust biological assays, holds the key to advancing this promising class of cholesterol-lowering agents.

Need Custom Synthesis?

BenchChem offers custom synthesis for rare earth carbides and specific isotopic labeling.

Email: info@benchchem.com or [Request Quote Online](#).

References

- [1. rcsb.org \[rcsb.org\]](#)
- [2. rcsb.org \[rcsb.org\]](#)
- [3. rcsb.org \[rcsb.org\]](#)
- [4. rcsb.org \[rcsb.org\]](#)
- [5. PDBe Connect Pages \[ebi.ac.uk\]](#)
- [6. researchgate.net \[researchgate.net\]](#)
- [7. mdpi.com \[mdpi.com\]](#)
- [8. Finding inhibitors for PCSK9 using computational methods | PLOS One \[journals.plos.org\]](#)
- [9. Finding inhibitors for PCSK9 using computational methods - PMC \[pmc.ncbi.nlm.nih.gov\]](#)
- [10. Identification of Potent Small-Molecule PCSK9 Inhibitors Based on Quantitative Structure-Activity Relationship, Pharmacophore Modeling, and Molecular Docking Procedure - PubMed \[pubmed.ncbi.nlm.nih.gov\]](#)
- [11. mdpi.com \[mdpi.com\]](#)
- [12. bpsbioscience.com \[bpsbioscience.com\]](#)

- [13. Recombinant human PCSK9 protein \(ab198471\) | Abcam \[abcam.com\]](#)
- [14. sinobiological.com \[sinobiological.com\]](#)
- [15. Recombinant Human PCSK9 Protein, 29698-H05H1-B | Sino Biological \[sinobiological.com\]](#)
- [16. benchchem.com \[benchchem.com\]](#)
- [17. bpsbioscience.com \[bpsbioscience.com\]](#)
- [18. bpsbioscience.com \[bpsbioscience.com\]](#)
- [19. bpsbioscience.com \[bpsbioscience.com\]](#)
- [20. resources.novusbio.com \[resources.novusbio.com\]](#)
- [21. benchchem.com \[benchchem.com\]](#)
- [22. benchchem.com \[benchchem.com\]](#)
- [23. LDL Cholesterol Uptake Assay Using Live Cell Imaging Analysis with Cell Health Monitoring - PMC \[pmc.ncbi.nlm.nih.gov\]](#)
- [24. walshmedicalmedia.com \[walshmedicalmedia.com\]](#)
- [25. researchgate.net \[researchgate.net\]](#)
- [To cite this document: BenchChem. \[Crystal Structure of PCSK9 with Small Molecule Ligands: An In-depth Technical Guide\]. BenchChem, \[2026\]. \[Online PDF\]. Available at: \[https://www.benchchem.com/product/b12366527/docs#crystal-structure-of-pcsk9-with-small-molecule-ligands-an-in-depth-technical-guide\]](#)

Disclaimer & Data Validity:

The information provided in this document is for Research Use Only (RUO) and is strictly not intended for diagnostic or therapeutic procedures. While BenchChem strives to provide accurate protocols, we make no warranties, express or implied, regarding the fitness of this product for every specific experimental setup.

Technical Support: The protocols provided are for reference purposes. Unsure if this reagent suits your experiment?

Need Industrial/Bulk Grade? [Request Custom Synthesis Quote](#)

BenchChem

Our mission is to be the trusted global source of essential and advanced chemicals, empowering scientists and researchers to drive progress in science and industry.

Contact

Address: 3281 E Guasti Rd

Ontario, CA 91761, United States

Phone: (601) 213-4426

Email: info@benchchem.com

[Contact our Ph.D. Support Team for a compatibility check](#)