

BI-4732 In Vivo Studies: Technical Support Center

Author: BenchChem Technical Support Team. **Date:** April 2026

Compound of Interest

Compound Name: BI-4732
Cat. No.: B12365538

[Get Quote](#)

This technical support center provides troubleshooting guides and frequently asked questions (FAQs) for researchers and scientists using **BI-4732** in in vivo studies.

Frequently Asked Questions (FAQs)

Q1: What is **BI-4732** and what is its mechanism of action?

BI-4732 is an orally active, reversible, and ATP-competitive fourth-generation epidermal growth factor receptor (EGFR) inhibitor.[1][2] It is designed to target EGFR-activating mutations (such as E19del and L858R) as well as the T790M and C797S resistance mutations that can emerge after treatment with earlier-generation EGFR tyrosine kinase inhibitors (TKIs).[3][4][5] **BI-4732** works by inhibiting the kinase activity of these EGFR mutants, thereby blocking downstream signaling pathways like RAS-RAF-MEK-ERK and PI3K-AKT, which are crucial for cell proliferation and survival.[1][5] Notably, it spares wild-type EGFR, which may reduce some of the side effects associated with less selective EGFR inhibitors.[2][6]

Q2: In which cancer models is **BI-4732** expected to be effective?

BI-4732 has demonstrated significant antitumor efficacy in preclinical models of non-small cell lung cancer (NSCLC) harboring various EGFR mutations.[3][4] It is particularly effective in

models with the C797S mutation, which confers resistance to third-generation TKIs like osimertinib.[3][7] Efficacy has been shown in patient-derived xenograft (PDX), cell-derived xenograft (CDX), and organoid models with EGFR mutations.[3][4] Given its excellent blood-brain barrier penetration, **BI-4732** is also highly effective in intracranial tumor models.[3][4][7]

Q3: What are the key advantages of using **BI-4732** in preclinical studies?

The primary advantages of **BI-4732** include:

- Broad activity against resistance mutations: It potently inhibits EGFR with the C797S mutation, a key mechanism of resistance to osimertinib.[3][7]
- High potency: It demonstrates low nanomolar IC50 values against relevant EGFR mutations. [1][2]
- Excellent blood-brain barrier penetration: This makes it a promising agent for studying and treating brain metastases.[3][4][6]
- Oral bioavailability: **BI-4732** is orally active, simplifying its administration in in vivo studies.[1][6]
- Synergistic potential: It has shown synergistic effects when used in combination with osimertinib.[3][4][7]

Troubleshooting Guide

Observed Issue	Potential Cause	Recommended Action
Suboptimal tumor growth inhibition	Incorrect dosage or administration schedule.	The effective dose can vary between models. In a YU-1097 xenograft model, oral administration of 2.5, 5, 10, and 25 mg/kg twice daily resulted in significant tumor growth inhibition. ^[1] Consider dose-response studies to determine the optimal dose for your specific model.
Poor drug formulation or stability.	For oral administration, BI-4732 can be formulated in 0.5% natrosol (acidified with HCl). ^[6] Ensure the formulation is prepared fresh and administered consistently.	
Tumor model heterogeneity.	The genetic background of the tumor model is critical. Confirm the presence of the target EGFR mutations (e.g., E19del, T790M, C797S) in your cell lines or PDX models.	
Unexpected Toxicity or Adverse Effects (e.g., weight loss)	Off-target effects or high dosage.	Although BI-4732 spares wild-type EGFR, high doses may still lead to toxicity. Monitor animal body weight and general health daily. If significant weight loss is observed, consider reducing the dose or adjusting the treatment schedule. In a YU-1097 xenograft study, mice treated with BI-4732 did not

show significant body weight changes.[8]

Formulation issues. The vehicle used for administration could contribute to toxicity. Ensure the vehicle is well-tolerated by the animal model.

Variability in Results Between Animals

Inconsistent tumor implantation.

Ensure consistent cell numbers and injection volumes for subcutaneous or orthotopic implantation. For the YU-1097 xenograft model, 5×10^6 cells in 100 μ L PBS were implanted subcutaneously.[1][7]

Differences in drug metabolism.

While BI-4732 has shown high bioavailability in mice and rats[6], individual animal metabolism can vary. Ensure a sufficiently large cohort to account for biological variability.

Challenges in Intracranial Models

Inadequate drug delivery to the brain.

BI-4732 has demonstrated superior brain permeability compared to osimertinib.[6] However, ensure proper administration to maximize systemic exposure.

Tumor take-rate and monitoring.

Intracranial tumor models can be challenging to establish and monitor. Utilize non-invasive imaging techniques (e.g., bioluminescence, MRI) to track tumor growth and response to treatment.

Quantitative Data Summary

Table 1: In Vitro Antiproliferative Activity of BI-4732

Cell Line	EGFR Mutation Status	IC50 (nM)
YU-1182	73	
YU-1097	E19del/T790M/C797S	3
YUO-143	5	
PC9	14	
PC9_DC	25	

Data sourced from
MedchemExpress product
information.[1]

Table 2: In Vivo Dosing and Efficacy in a YU-1097 Xenograft Model

Treatment Group	Dosage	Administration Route	Tumor Growth Inhibition (TGI)
BI-4732	2.5 mg/kg	p.o. twice daily	143.1%
BI-4732	5 mg/kg	p.o. twice daily	-
BI-4732	10 mg/kg	p.o. twice daily	-
BI-4732	25 mg/kg	p.o. twice daily	-
BI-4732 + Osimertinib	5 mg/kg + 25 mg/kg	p.o. twice daily	-

Data for TGI was only
available for the 2.5
mg/kg dose group.[1]

Experimental Protocols

1. Cell-Derived Xenograft (CDX) Model for Antitumor Activity

- Cell Line: YU-1097 (harboring EGFR E19del/T790M/C797S mutations).[1]
- Animals: 6-week-old female BALB/c nude mice.[1][7]
- Implantation: 5×10^6 YU-1097 cells in 100 μ L of PBS are subcutaneously implanted into the flanks of the mice.[1][7]
- Treatment: Once tumors reach a palpable size, animals are randomized into treatment groups. **BI-4732** is administered orally (p.o.) twice daily for a specified period (e.g., 4 weeks). [1]
- Monitoring: Tumor volume and body weight are measured regularly (e.g., twice weekly). Tumor volume can be calculated using the formula: $(\text{length} \times \text{width}^2) / 2$.
- Endpoint: The study can be concluded when tumors in the control group reach a predetermined size, or at the end of the treatment period. Tumor growth inhibition (TGI) is calculated to assess efficacy.

2. Intracranial Brain-Metastasis Mouse Model

- Objective: To evaluate the intracranial antitumor activity of **BI-4732**. [3][4]
- Methodology: While the specific cell line and implantation technique are not detailed in the provided search results, a general protocol involves the stereotactic injection of luciferase-tagged tumor cells into the brain of immunodeficient mice.
- Treatment: Oral administration of **BI-4732** at a predetermined dose and schedule.
- Monitoring: Tumor growth is monitored non-invasively using bioluminescence imaging. Animal survival and neurological symptoms are also recorded.
- Endpoint: Analysis of median survival and changes in tumor burden.

Visualizations

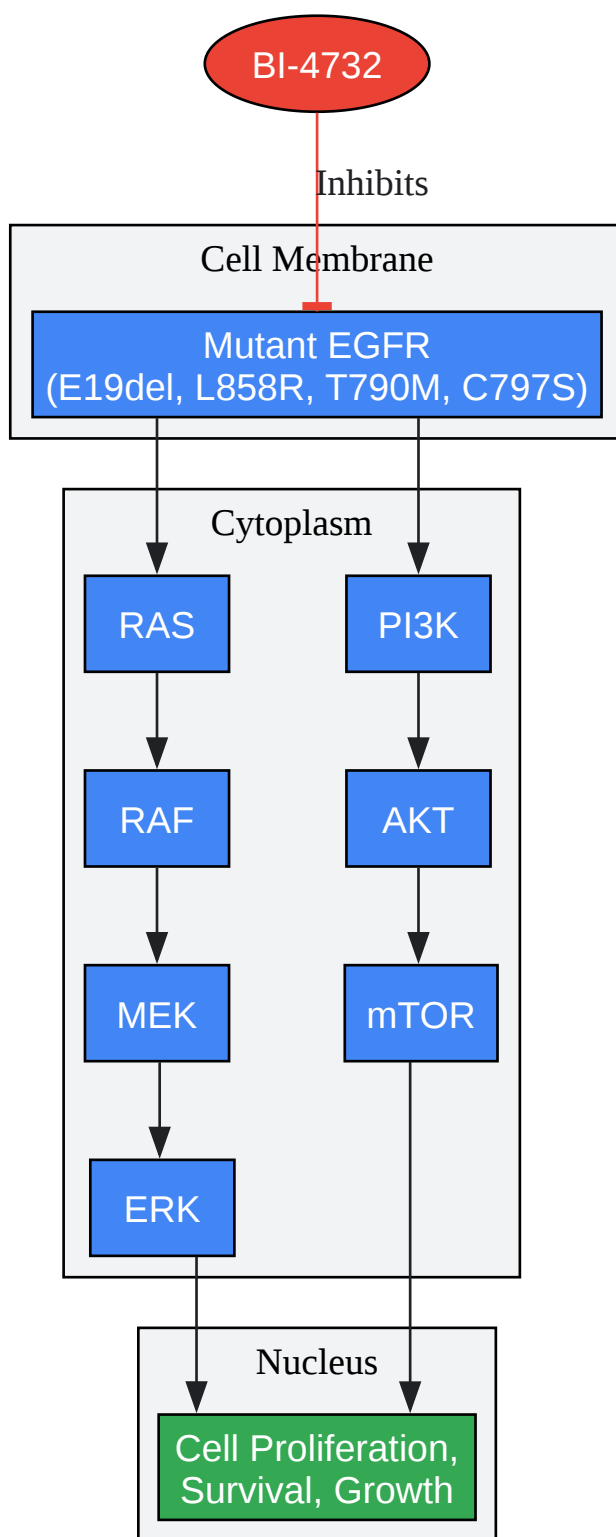

[Click to download full resolution via product page](#)

Caption: EGFR signaling pathway and the inhibitory action of **BI-4732**.

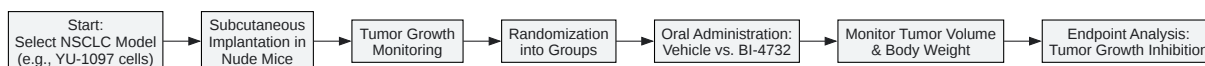

[Click to download full resolution via product page](#)

Caption: General experimental workflow for a subcutaneous xenograft model.

Need Custom Synthesis?

BenchChem offers custom synthesis for rare earth carbides and specific isotopic labeling.

Email: info@benchchem.com or [Request Quote Online](#).

References

- [1. medchemexpress.com \[medchemexpress.com\]](https://www.medchemexpress.com)
- [2. Pardon Our Interruption \[opnme.com\]](https://www.opnme.com)
- [3. Discovery of a Novel Potent EGFR Inhibitor Against EGFR Activating Mutations and On-Target Resistance in NSCLC - PubMed \[pubmed.ncbi.nlm.nih.gov\]](https://pubmed.ncbi.nlm.nih.gov)
- [4. Discovery of a Novel Potent EGFR Inhibitor Against EGFR Activating Mutations and On-Target Resistance in NSCLC | Clinical Cancer Research | American Association for Cancer Research \[aacrjournals.org\]](https://aacrjournals.org)
- [5. Pardon Our Interruption \[opnme.com\]](https://www.opnme.com)
- [6. Pardon Our Interruption \[opnme.com\]](https://www.opnme.com)
- [7. Discovery of a Novel Potent EGFR Inhibitor Against EGFR Activating Mutations and On-Target Resistance in NSCLC | Clinical Cancer Research | American Association for Cancer Research \[aacrjournals.org\]](https://aacrjournals.org)
- [8. researchgate.net \[researchgate.net\]](https://www.researchgate.net)
- To cite this document: BenchChem. [BI-4732 In Vivo Studies: Technical Support Center]. BenchChem, [2026]. [Online PDF]. Available at: [\[https://www.benchchem.com/product/b12365538/docs#bi-4732-in-vivo-studies-technical-support-center\]](https://www.benchchem.com/product/b12365538/docs#bi-4732-in-vivo-studies-technical-support-center)

Disclaimer & Data Validity:

The information provided in this document is for Research Use Only (RUO) and is strictly not intended for diagnostic or therapeutic procedures. While BenchChem strives to provide accurate protocols, we make no warranties, express or implied, regarding the fitness of this product for every specific experimental setup.

Technical Support: The protocols provided are for reference purposes. Unsure if this reagent suits your experiment?

Need Industrial/Bulk Grade? [Request Custom Synthesis Quote](#)

BenchChem

Our mission is to be the trusted global source of essential and advanced chemicals, empowering scientists and researchers to drive progress in science and industry.

Contact

Address: 3281 E Guasti Rd
Ontario, CA 91761, United States
Phone: (601) 213-4426
Email: info@benchchem.com

[Contact our Ph.D. Support Team for a compatibility check](#)