

Technical Support Center: Pan-KRAS-IN-6 and Feedback Loop Activation

Author: BenchChem Technical Support Team. **Date:** April 2026

Compound of Interest

Compound Name: *pan-KRAS-IN-6*

Cat. No.: *B12363412*

[Get Quote](#)

This technical support center provides troubleshooting guidance and frequently asked questions (FAQs) for researchers utilizing **pan-KRAS-IN-6** and investigating the associated feedback loop activation.

Frequently Asked Questions (FAQs)

Q1: What is the mechanism of action for **pan-KRAS-IN-6**?

Pan-KRAS-IN-6 is a pan-KRAS inhibitor, meaning it is designed to inhibit multiple KRAS mutants. These types of inhibitors often function by disrupting the interaction between KRAS and its activating proteins, such as the guanine nucleotide exchange factor (GEF) Son of Sevenless 1 (SOS1). By preventing this interaction, the inhibitor blocks the exchange of GDP for GTP, keeping KRAS in an inactive state and thereby inhibiting downstream oncogenic signaling pathways like the MAPK and PI3K/AKT pathways.^{[1][2][3]}

Q2: What is the "feedback loop activation" observed with pan-KRAS inhibitor treatment?

Feedback loop activation is a resistance mechanism that can occur following treatment with pan-KRAS inhibitors.^{[2][4]} Inhibition of the KRAS pathway can lead to the reactivation of upstream signaling molecules, most notably Receptor Tyrosine Kinases (RTKs). This

reactivation can then lead to the recruitment and activation of SOS1, which promotes the loading of GTP onto wild-type RAS proteins or uninhibited mutant KRAS, ultimately causing a rebound in downstream signaling, such as the phosphorylation of ERK (p-ERK).

Q3: Why do I observe a rebound in p-ERK levels after an initial decrease with **pan-KRAS-IN-6** treatment?

A rebound in phosphorylated ERK (p-ERK) levels is a hallmark of feedback loop activation. While **pan-KRAS-IN-6** initially inhibits KRAS and downstream signaling, this can trigger a compensatory feedback mechanism. The cell may upregulate RTK signaling, which in turn activates SOS1 and leads to the reactivation of the MAPK pathway, manifesting as a recovery of p-ERK levels, often observed at later time points (e.g., 24-48 hours) after treatment.

Q4: Are there strategies to overcome this feedback-mediated resistance?

Yes, several strategies are being explored to overcome feedback resistance. One common approach is combination therapy. Co-treatment with inhibitors of upstream signaling molecules, such as RTK inhibitors or SHP2 inhibitors (which acts downstream of many RTKs and upstream of SOS1), can help to abrogate the feedback loop and enhance the efficacy of the pan-KRAS inhibitor.

Troubleshooting Guides

Cell Viability Assays (e.g., MTT, CellTiter-Glo)

Problem	Possible Causes	Troubleshooting Steps
Higher than expected IC50 value or no significant effect on cell viability.	<p>1. Cell line is not dependent on KRAS signaling: The chosen cell line may have alternative survival pathways. 2. Feedback loop activation: Compensatory signaling is rescuing the cells from the inhibitory effects. 3. Compound instability: The inhibitor may be degrading in the culture medium over the incubation period. 4. Incorrect inhibitor concentration.</p>	<p>1. Confirm KRAS dependency: Use a positive control cell line known to be sensitive to KRAS inhibition. Consider siRNA-mediated knockdown of KRAS to confirm dependency. 2. Time-course experiment: Assess cell viability at earlier time points before the feedback loop is fully established. 3. Replenish media: For longer experiments, consider replenishing the media with fresh inhibitor. 4. Dose-response curve: Perform a wide-range dose-response experiment to ensure an appropriate concentration range is being tested.</p>
High variability between replicate wells.	<p>1. Uneven cell seeding. 2. Edge effects in the 96-well plate. 3. Compound precipitation.</p>	<p>1. Ensure a single-cell suspension: Mix cells thoroughly before and during seeding. 2. Avoid using outer wells: The outer wells of a 96-well plate are more prone to evaporation. Fill them with sterile PBS or media. 3. Check solubility: Visually inspect the media for any signs of precipitation after adding the inhibitor. Consider pre-diluting the compound in a small volume of media before adding to the wells.</p>

Western Blotting for Signaling Pathway Analysis

Problem	Possible Causes	Troubleshooting Steps
No decrease in p-ERK or p-AKT levels after treatment.	<ol style="list-style-type: none"> Ineffective inhibitor concentration. Timing of cell lysis: The feedback loop may have already reactivated the pathway. Poor antibody quality. 	<ol style="list-style-type: none"> Titrate inhibitor concentration: Test a range of concentrations to find the optimal dose for pathway inhibition. Perform a time-course experiment: Harvest cell lysates at early time points (e.g., 2, 4, 6 hours) to observe the initial inhibition before the rebound. Validate antibodies: Use a positive control (e.g., cells stimulated with a growth factor) and a negative control to ensure antibody specificity and sensitivity.
Weak or no signal for target proteins.	<ol style="list-style-type: none"> Low protein concentration in lysate. Insufficient primary antibody concentration or incubation time. Inactive secondary antibody or substrate. 	<ol style="list-style-type: none"> Quantify protein concentration: Use a BCA or Bradford assay to ensure equal loading. Optimize antibody conditions: Increase the primary antibody concentration or extend the incubation time (e.g., overnight at 4°C). Check reagents: Ensure the secondary antibody and chemiluminescent substrate are not expired and have been stored correctly.

Rebound of p-ERK is observed, confirming feedback.

N/A - This is an expected biological phenomenon with this class of inhibitors.

This observation validates the presence of a feedback loop. To investigate further, consider co-treatment with an RTK or SHP2 inhibitor to see if the rebound is abrogated.

Quantitative Data

Table 1: Pan-KRAS Inhibitor Activity in Different Cancer Cell Lines

Inhibitor	Cell Line	KRAS Mutation	IC50 (μM)
BI-2852	Various PDAC Cell Lines	G12D, G12V, G13D	18.83 to >100
BAY-293	Various PDAC Cell Lines	G12D, G12V, G13D	0.95 to 6.64
BI-2852	Various CRC Cell Lines	Various	19.21 to >100
BAY-293	Various CRC Cell Lines	Various	1.15 to 5.26

PDAC: Pancreatic Ductal Adenocarcinoma, CRC: Colorectal Cancer. Data extracted from a study by Wang et al., 2022.

Experimental Protocols

Protocol 1: Cell Proliferation Assay (MTS/MTT)

- Cell Seeding:
 - Harvest and count cells, ensuring they are in the logarithmic growth phase.
 - Seed cells into a 96-well plate at a density of 3,000-5,000 cells per well in 100 μL of complete culture medium.

- Incubate overnight to allow for cell attachment.
- Compound Treatment:
 - Prepare serial dilutions of **pan-KRAS-IN-6** in culture medium at 2x the final desired concentration.
 - Remove the existing medium from the cells and add 100 μ L of the compound dilutions to the respective wells. Include a vehicle control (e.g., DMSO at the same final concentration as the highest inhibitor dose).
 - Incubate for 72 hours at 37°C in a 5% CO₂ incubator.
- MTS/MTT Assay:
 - Add 20 μ L of MTS or MTT reagent to each well.
 - Incubate for 1-4 hours at 37°C.
 - Measure the absorbance at the appropriate wavelength (e.g., 490 nm for MTS) using a microplate reader.
- Data Analysis:
 - Subtract the background absorbance (from wells with medium only).
 - Normalize the data to the vehicle control (set to 100% viability).
 - Plot the percent viability against the logarithm of the inhibitor concentration and use non-linear regression to calculate the IC₅₀ value.

Protocol 2: Western Blot for Downstream Signaling

- Cell Treatment and Lysis:
 - Seed cells in 6-well plates and grow to 70-80% confluency.
 - Treat cells with varying concentrations of **pan-KRAS-IN-6** and a vehicle control for the desired time points (e.g., 2, 6, 24 hours).

- After treatment, wash cells with ice-cold PBS.
- Lyse cells in RIPA buffer supplemented with protease and phosphatase inhibitors. Scrape the cells, collect the lysate, and centrifuge to pellet cell debris.
- Protein Quantification:
 - Determine the protein concentration of each lysate using a BCA or Bradford assay.
- SDS-PAGE and Transfer:
 - Denature equal amounts of protein (e.g., 20-30 μg) by boiling in Laemmli buffer.
 - Separate proteins by SDS-PAGE and transfer to a PVDF or nitrocellulose membrane.
- Immunoblotting:
 - Block the membrane with 5% non-fat dry milk or BSA in TBST for 1 hour at room temperature.
 - Incubate the membrane with primary antibodies (e.g., rabbit anti-phospho-ERK1/2, rabbit anti-total-ERK1/2) overnight at 4°C.
 - Wash the membrane with TBST and incubate with an HRP-conjugated anti-rabbit secondary antibody for 1 hour at room temperature.
 - Wash again and add a chemiluminescent substrate.
- Detection and Analysis:
 - Visualize the protein bands using an imaging system.
 - Quantify band intensities using densitometry software. Normalize the phosphorylated protein signal to the total protein signal for each sample.

Visualizations

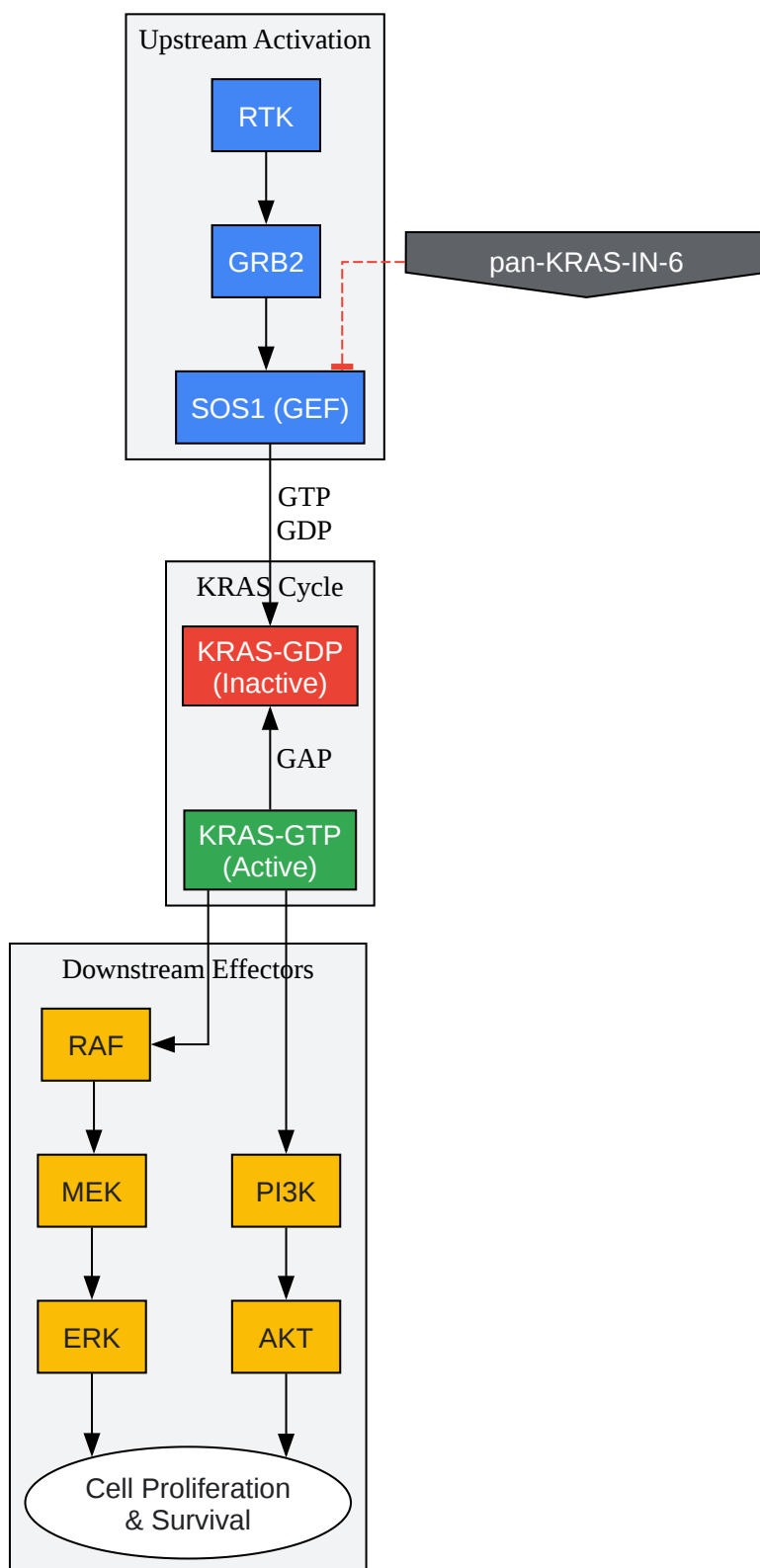

[Click to download full resolution via product page](#)

Caption: KRAS signaling pathway and the inhibitory action of **pan-KRAS-IN-6**.

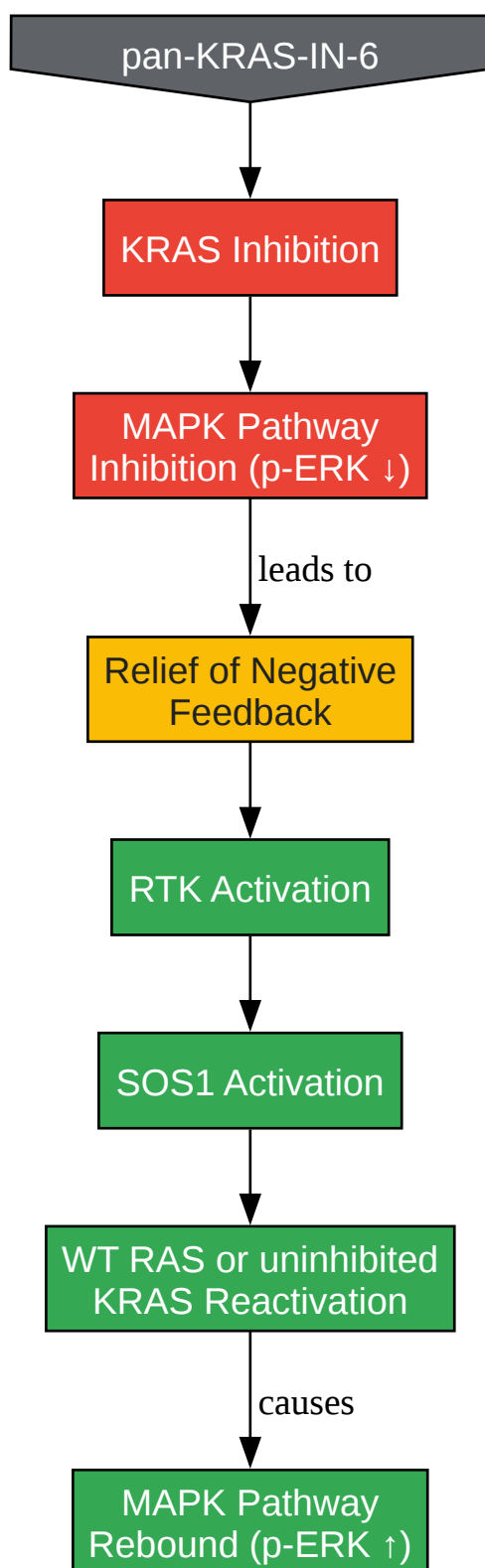

[Click to download full resolution via product page](#)

Caption: Feedback loop activation upon pan-KRAS inhibitor treatment.

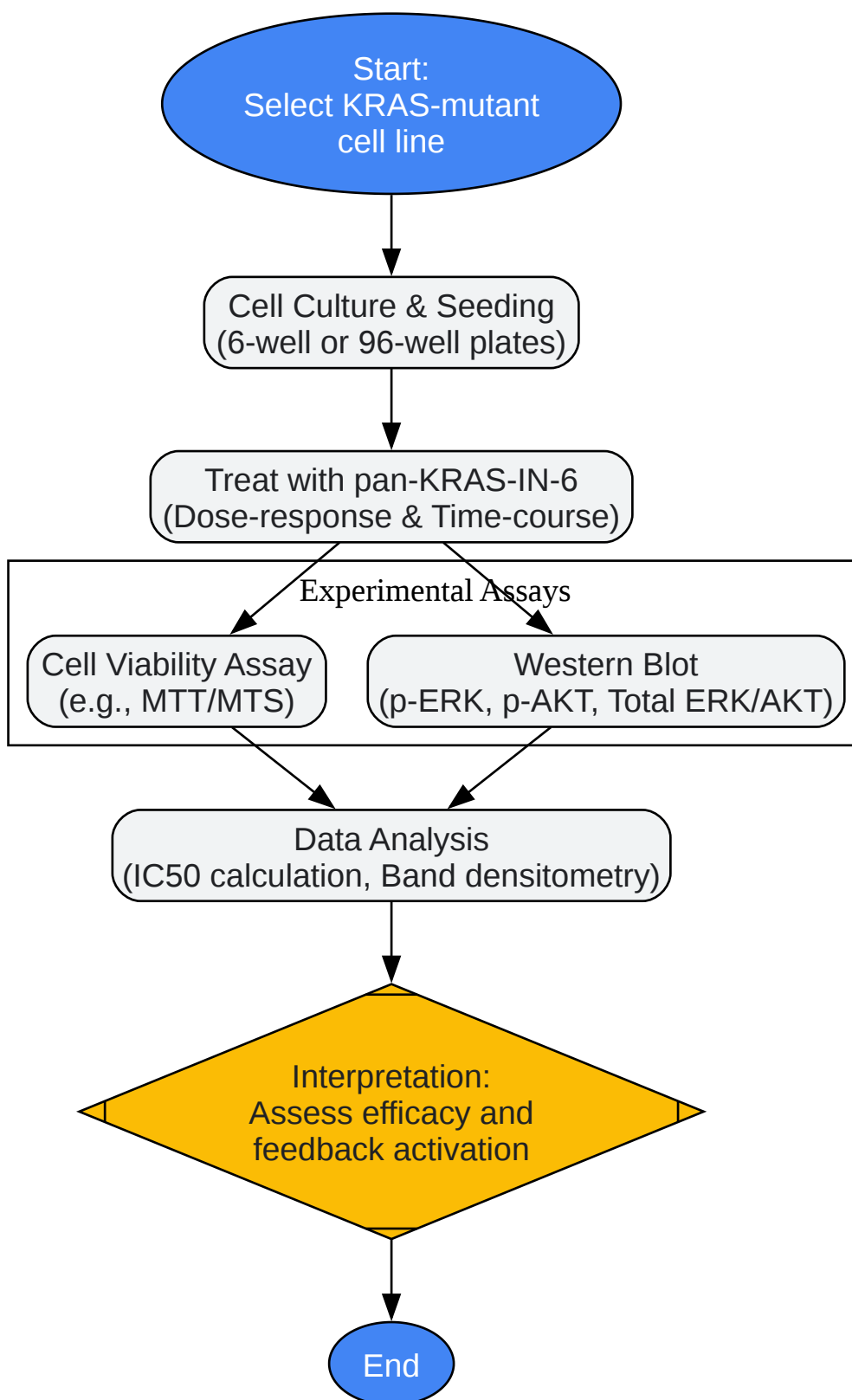

[Click to download full resolution via product page](#)

Caption: General experimental workflow for evaluating **pan-KRAS-IN-6**.

Need Custom Synthesis?

BenchChem offers custom synthesis for rare earth carbides and specific isotopic labeling.

Email: info@benchchem.com or [Request Quote Online](#).

References

- [1. benchchem.com \[benchchem.com\]](#)
- [2. Pan-KRAS inhibitors suppress proliferation through feedback regulation in pancreatic ductal adenocarcinoma - PMC \[pmc.ncbi.nlm.nih.gov\]](#)
- [3. benchchem.com \[benchchem.com\]](#)
- [4. Pan-KRAS inhibitors suppress proliferation through feedback regulation in pancreatic ductal adenocarcinoma - PubMed \[pubmed.ncbi.nlm.nih.gov\]](#)
- To cite this document: BenchChem. [Technical Support Center: Pan-KRAS-IN-6 and Feedback Loop Activation]. BenchChem, [2026]. [Online PDF]. Available at: [\[https://www.benchchem.com/product/b12363412/docs#technical-support-center-pan-kras-in-6-and-feedback-loop-activation\]](https://www.benchchem.com/product/b12363412/docs#technical-support-center-pan-kras-in-6-and-feedback-loop-activation)

Disclaimer & Data Validity:

The information provided in this document is for Research Use Only (RUO) and is strictly not intended for diagnostic or therapeutic procedures. While BenchChem strives to provide accurate protocols, we make no warranties, express or implied, regarding the fitness of this product for every specific experimental setup.

Technical Support: The protocols provided are for reference purposes. Unsure if this reagent suits your experiment?

Need Industrial/Bulk Grade? [Request Custom Synthesis Quote](#)

BenchChem

Our mission is to be the trusted global source of essential and advanced chemicals, empowering scientists and researchers to drive progress in science and industry.

Contact

Address: 3281 E Guasti Rd

Ontario, CA 91761, United States

Phone: (601) 213-4426

Email: info@benchchem.com

[Contact our Ph.D. Support Team for a compatibility check](#)