

# Application Notes and Protocols for *T. congolense* Drug Sensitivity Testing

**Author:** BenchChem Technical Support Team. **Date:** April 2026

## Compound of Interest

Compound Name: *Antitrypanosomal agent 16*

Cat. No.: B12363515

[Get Quote](#)

Audience: Researchers, scientists, and drug development professionals.

Introduction: *Trypanosoma congolense* is a major causative agent of Animal African Trypanosomiasis (AAT), a debilitating livestock disease prevalent in sub-Saharan Africa.<sup>[1][2]</sup> The development of new, effective trypanocidal drugs is crucial, and this relies on robust and reproducible in vitro methods for assessing drug sensitivity. These application notes provide detailed protocols for the in vitro culture of *T. congolense* bloodstream forms (BSF) and subsequent drug sensitivity testing using common viability assays.

## Part 1: In Vitro Culture of *T. congolense* Bloodstream Forms

Successful drug sensitivity testing begins with the consistent and reliable in vitro cultivation of the parasite. While the entire life cycle of *T. congolense* can be completed in vitro, research on new therapeutics appropriately focuses on the mammalian BSF stage.<sup>[1][2][3][4]</sup> Several media formulations have been developed for the long-term culture of *T. congolense* BSF, often without the need for feeder cell layers.<sup>[5]</sup>

## Culture Media and Reagents

A commonly used medium is a modification of Iscove's Modified Dulbecco's Medium (IMDM), such as HMI-93.[5]

Table 1: Composition of Modified HMI-93 Medium for *T. congolense* BSF Culture[5]

| Component                   | Final Concentration | Purpose                      |
|-----------------------------|---------------------|------------------------------|
| IMDM Base Medium            | -                   | Basal nutrient source        |
| Heat-Inactivated Goat Serum | 20% (v/v)           | Growth factors and nutrients |
| Serum Plus™                 | 5% (v/v)            | Growth enhancement           |
| L-Cysteine                  | 1.5 mM              | Reducing agent               |
| Hypoxanthine                | 0.5 mM              | Purine source                |
| 2-Mercaptoethanol           | 0.12 mM             | Reducing agent, antioxidant  |
| Sodium Pyruvate             | 1 mM                | Energy source                |
| Thymidine                   | 0.16 mM             | Pyrimidine source            |
| Bathocuproine sulphonate    | 0.05 mM             | Iron chelator                |

## Culture Protocol

- Initiation: Cultures can be initiated from in vitro-produced metacyclic forms or from bloodstream forms isolated from an infected mouse.[5]
- Vessel: Use standard 25 cm<sup>2</sup> tissue culture flasks (T-25).[5]
- Incubation: Incubate flasks at 34-36°C.[5] A CO<sub>2</sub>-enriched atmosphere (typically 5%) is often required.
- Maintenance: *T. congolense* BSF tend to attach to the bottom of the culture flask.[5] Replace the culture medium every 24 hours to replenish nutrients and remove waste products.[5]
- Subculturing: Every 4-5 days, or when the culture reaches the desired confluency, resuspend the attached trypanosomes by gentle pipetting.[5] Dilute the cell suspension into a new flask

with fresh medium. A common seeding density to achieve a population doubling time of approximately 9 hours is  $1 \times 10^6$  bloodstream forms/ml.[5]

## Part 2: Drug Sensitivity Testing Assays

Whole-cell screening assays are a primary method for identifying new trypanocidal compounds. [6][7] The following protocols describe two common, fluorescence-based methods for determining the 50% inhibitory concentration (IC50) of test compounds.

### Protocol 1: Alamar Blue (Resazurin) Viability Assay

This assay measures metabolic activity. The non-fluorescent dye resazurin (blue) is reduced by viable, metabolically active cells to the highly fluorescent resorufin (pink).[8]

Table 2: Key Parameters for Alamar Blue Assay

| Parameter                 | Recommended Value                                 |
|---------------------------|---|
| Plate Format              | 96- or 384-well, clear bottom, black plates       |
| Initial Cell Density      | $1 \times 10^4$ - $1 \times 10^5$ trypanosomes/ml |
| Drug Incubation Period    | 48 - 72 hours                                     |
| Alamar Blue Concentration | 10% of final assay volume                         |
| Alamar Blue Incubation    | 2-4 hours (signal development)                    |
| Fluorescence Reading      | Excitation: 530-560 nm, Emission: 590 nm          |

#### Experimental Protocol:

- Cell Preparation: Harvest T. congolense from culture, count the cells, and adjust the concentration to the desired seeding density in fresh culture medium.
- Plate Seeding: Dispense the cell suspension into the wells of a microtiter plate.
- Compound Addition: Add serial dilutions of the test compounds to the wells. Include a "no drug" control (positive growth) and a "no cells" control (background fluorescence). A standard trypanocide like diminazene aceturate should be used as a positive control for inhibition.[8]

- Incubation: Incubate the plate for 48-72 hours at 34-36°C in a 5% CO<sub>2</sub> atmosphere.
- Reagent Addition: Add Alamar Blue reagent to each well to a final concentration of 10%.[\[6\]](#)[\[9\]](#)
- Signal Development: Incubate for an additional 2-4 hours under the same conditions to allow for the color change.[\[6\]](#)
- Fluorescence Measurement: Read the fluorescence intensity using a plate reader at the appropriate excitation and emission wavelengths.

Workflow for Alamar Blue Drug Sensitivity Assay

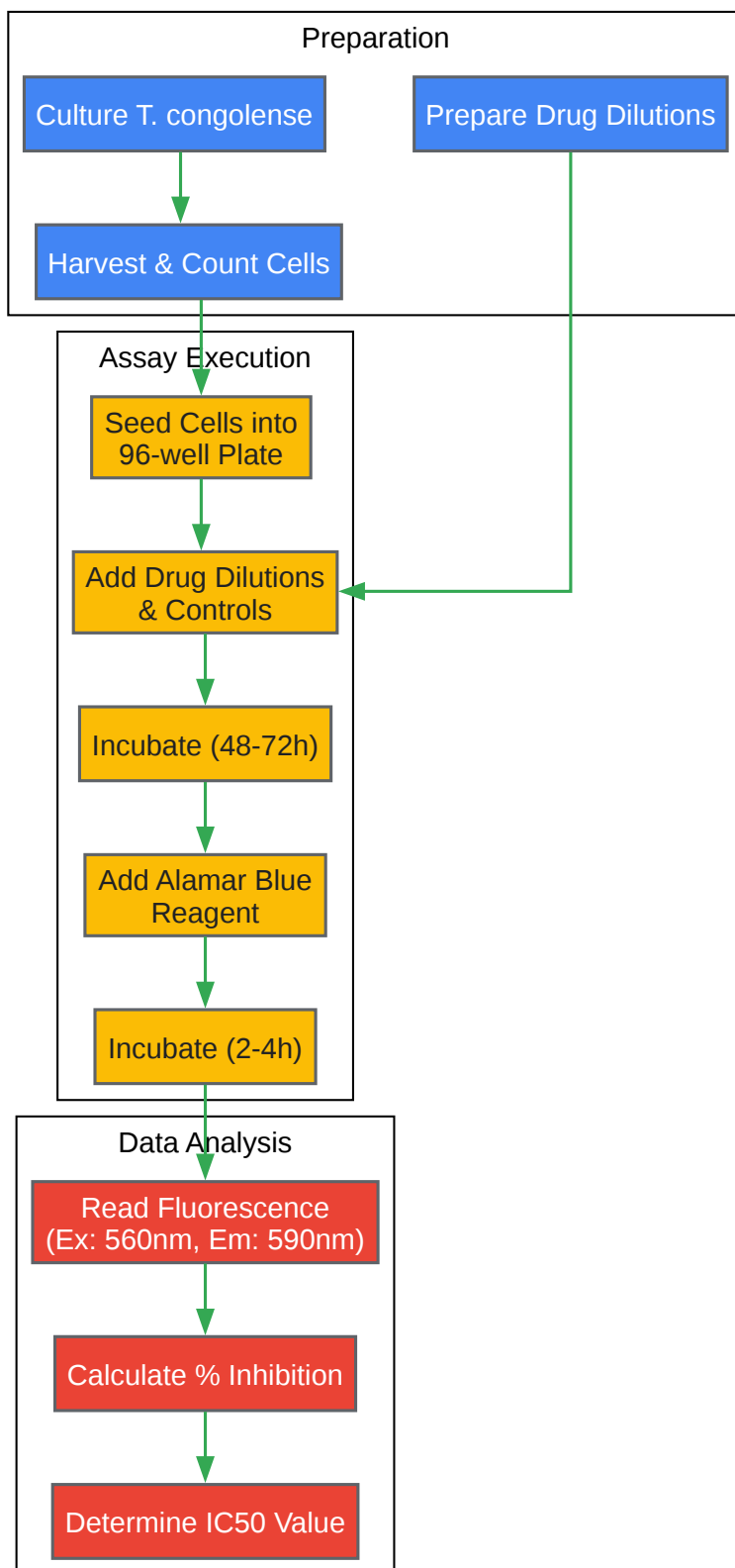

[Click to download full resolution via product page](#)

Caption: Workflow for *T. congolense* drug sensitivity testing using the Alamar Blue assay.

## Principle of the Alamar Blue (Resazurin) Assay

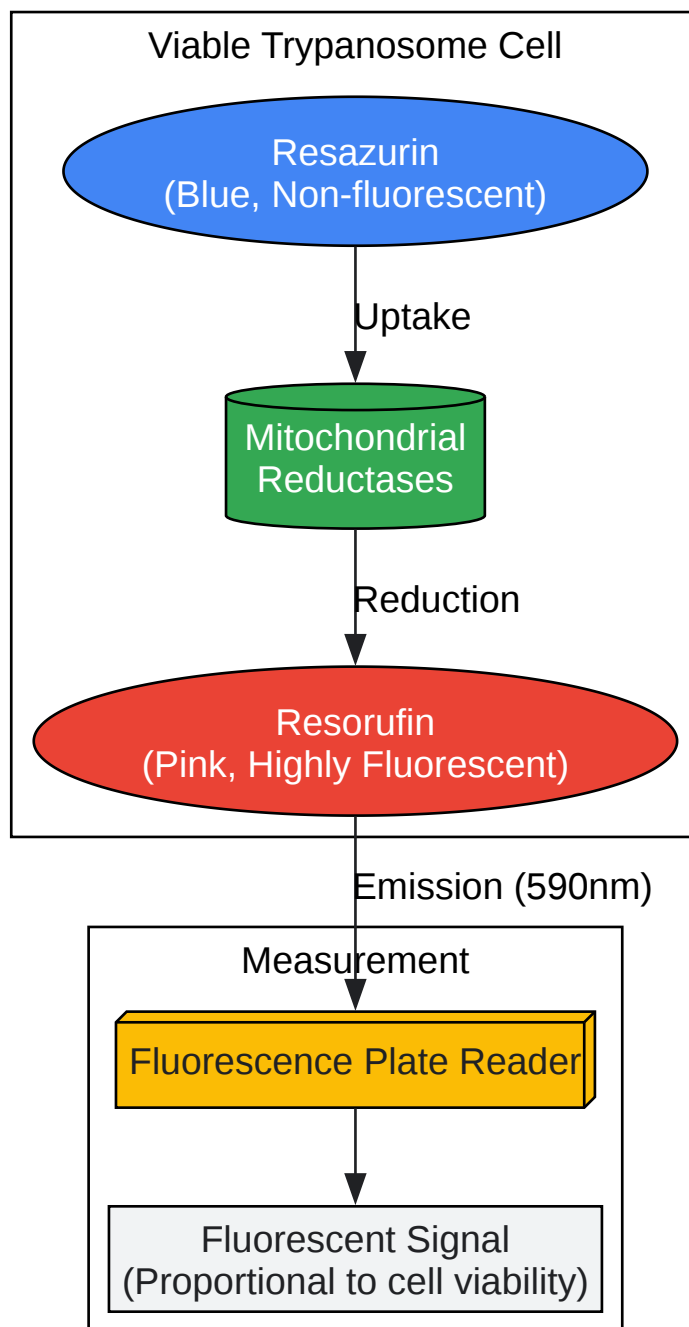

[Click to download full resolution via product page](#)

Caption: The metabolic conversion of resazurin to fluorescent resorufin by viable cells.

## Protocol 2: SYBR Green I-based Assay

This assay quantifies the proliferation of parasites by measuring the amount of DNA. SYBR Green I is a dye that intercalates with double-stranded DNA, emitting a strong fluorescent signal upon binding.[10][11] This method is highly sensitive and robust for high-throughput screening.[7]

Table 3: Key Parameters for SYBR Green I Assay

| Parameter               | Recommended Value                      |
|-------------------------|--|
| Plate Format            | 96- or 384-well, black plates          |
| Initial Cell Density    | ~2 x 10 <sup>3</sup> cells/well        |
| Drug Incubation Period  | 72 hours                               |
| Lysis Buffer Components | Tris, EDTA, Saponin, SYBR Green I      |
| Lysis Incubation        | 1 hour at room temperature (in dark)   |
| Fluorescence Reading    | Excitation: ~485 nm, Emission: ~520 nm |

#### Experimental Protocol:

- Cell Preparation & Seeding: Follow steps 1-3 from the Alamar Blue protocol.
- Incubation: Incubate the plate for 72 hours at 34-36°C in a 5% CO<sub>2</sub> atmosphere.
- Lysis and Staining: Add a prepared lysis buffer containing SYBR Green I to each well. This buffer lyses the cells to release the DNA for staining.
- Signal Development: Incubate the plate for at least 1 hour at room temperature, protected from light, to ensure complete lysis and DNA staining.
- Fluorescence Measurement: Read the fluorescence intensity using a plate reader with the appropriate filter set for SYBR Green I.

## Part 3: Data Analysis and Interpretation

The goal of the assay is to determine the IC<sub>50</sub> value, which is the concentration of a drug that inhibits 50% of parasite growth or metabolic activity compared to untreated controls.

## Calculating Percent Inhibition

For each drug concentration, calculate the percent inhibition using the following formula:

$$\% \text{ Inhibition} = 100 * [ 1 - ( (\text{Fluorescence\_Test} - \text{Fluorescence\_Blank}) / (\text{Fluorescence\_Control} - \text{Fluorescence\_Blank}) ) ]$$

Where:

- Fluorescence\_Test: Fluorescence of wells with cells and the test compound.
- Fluorescence\_Control: Fluorescence of wells with cells but no drug (maximum viability).
- Fluorescence\_Blank: Fluorescence of wells with medium only (background).

## Determining the IC50 Value

- Dose-Response Curve: Plot the percent inhibition (Y-axis) against the log of the drug concentration (X-axis).[12]
- Non-linear Regression: Use a statistical software package (e.g., GraphPad Prism, R, or an online calculator) to fit the data to a four-parameter logistic (sigmoidal) dose-response curve. [12]
- IC50 Extrapolation: The software will calculate the IC50 value, which corresponds to the drug concentration that produces 50% inhibition on the fitted curve.[12][13][14]

By following these detailed protocols, researchers can obtain reliable and reproducible data on the efficacy of novel compounds against *T. congolense*, a critical step in the drug discovery pipeline for Animal African Trypanosomiasis.

### *Need Custom Synthesis?*

*BenchChem offers custom synthesis for rare earth carbides and specific isotopic labeling.*

*Email: [info@benchchem.com](mailto:info@benchchem.com) or [Request Quote Online](#).*

## References

- [1. research-information.bris.ac.uk \[research-information.bris.ac.uk\]](https://research-information.bris.ac.uk)
- [2. researchgate.net \[researchgate.net\]](https://researchgate.net)
- [3. researchgate.net \[researchgate.net\]](https://researchgate.net)
- [4. Trypanosoma congolense: In Vitro Culture and Transfection - PubMed \[pubmed.ncbi.nlm.nih.gov\]](https://pubmed.ncbi.nlm.nih.gov)
- [5. In vitro cultivation of Trypanosoma congolense bloodstream forms in the absence of feeder cell layers - PubMed \[pubmed.ncbi.nlm.nih.gov\]](https://pubmed.ncbi.nlm.nih.gov)
- [6. Identification of Compounds with Anti-Proliferative Activity against Trypanosoma brucei brucei Strain 427 by a Whole Cell Viability Based HTS Campaign | PLOS Neglected Tropical Diseases \[journals.plos.org\]](https://journals.plos.org)
- [7. Drug discovery for human African trypanosomiasis: identification of novel scaffolds by the newly developed HTS SYBR Green assay for Trypanosoma brucei - PubMed \[pubmed.ncbi.nlm.nih.gov\]](https://pubmed.ncbi.nlm.nih.gov)
- [8. The Alamar Blue assay to determine drug sensitivity of African trypanosomes \(T.b. rhodesiense and T.b. gambiense\) in vitro - PubMed \[pubmed.ncbi.nlm.nih.gov\]](https://pubmed.ncbi.nlm.nih.gov)
- [9. research-repository.griffith.edu.au \[research-repository.griffith.edu.au\]](https://research-repository.griffith.edu.au)
- [10. researchgate.net \[researchgate.net\]](https://researchgate.net)
- [11. African trypanosomiasis: Sensitive and rapid detection of the sub-genus Trypanozoon by loop-mediated isothermal amplification \(LAMP\) of parasite DNA - PMC \[pmc.ncbi.nlm.nih.gov\]](https://pmc.ncbi.nlm.nih.gov)
- [12. Star Republic: Guide for Biologists \[sciencegateway.org\]](https://sciencegateway.org)
- [13. researchgate.net \[researchgate.net\]](https://researchgate.net)
- [14. itmedicalteam.pl \[itmedicalteam.pl\]](https://itmedicalteam.pl)
- To cite this document: BenchChem. [Application Notes and Protocols for T. congolense Drug Sensitivity Testing]. BenchChem, [2026]. [Online PDF]. Available at: [\[https://www.benchchem.com/product/b12363515/docs#application-notes-and-protocols-for-t-congolense-drug-sensitivity-testing\]](https://www.benchchem.com/product/b12363515/docs#application-notes-and-protocols-for-t-congolense-drug-sensitivity-testing)

---

### Disclaimer & Data Validity:

The information provided in this document is for Research Use Only (RUO) and is strictly not intended for diagnostic or therapeutic procedures. While BenchChem strives to provide

accurate protocols, we make no warranties, express or implied, regarding the fitness of this product for every specific experimental setup.

**Technical Support:** The protocols provided are for reference purposes. Unsure if this reagent suits your experiment?

**Need Industrial/Bulk Grade?** [Request Custom Synthesis Quote](#)

## BenchChem

Our mission is to be the trusted global source of essential and advanced chemicals, empowering scientists and researchers to drive progress in science and industry.

### Contact

Address: 3281 E Guasti Rd

Ontario, CA 91761, United States

Phone: (601) 213-4426

Email: [info@benchchem.com](mailto:info@benchchem.com)

[Contact our Ph.D. Support Team for a compatibility check](#)