

Application Notes and Protocols: AF 568 DBCO Protein Labeling

Author: BenchChem Technical Support Team. **Date:** April 2026

Compound of Interest

Compound Name: AF 568 DBCO

Cat. No.: B12363973

[Get Quote](#)

For Researchers, Scientists, and Drug Development Professionals

Introduction

The precise and covalent labeling of proteins is a fundamental technique in modern biological research and drug development. Strain-Promoted Azide-Alkyne Cycloaddition (SPAAC), a cornerstone of "click chemistry," offers a robust and bioorthogonal method for attaching probes to biomolecules. This application note provides detailed protocols for labeling azide-modified proteins with **AF 568 DBCO**, a bright and photostable fluorescent dye.^[1]

Dibenzocyclooctyne (DBCO) is one of the most reactive cyclooctynes used in copper-free click chemistry, reacting specifically and efficiently with azide-tagged molecules to form a stable triazole linkage.^{[2][3]} This reaction is biocompatible and can be performed in aqueous buffers under mild conditions, making it ideal for labeling sensitive proteins and for applications in living cells, as it does not require a cytotoxic copper catalyst.^{[1][2][4]} AF 568 is a hydrophilic fluorophore with an excitation maximum of approximately 579 nm and an emission maximum of around 603 nm, making it suitable for various fluorescence-based applications such as microscopy, flow cytometry, and in-gel fluorescence scanning.^{[5][6][7]}

Quantitative Data Summary

The efficiency of protein labeling with **AF 568 DBCO** can be assessed using several methods. The following table summarizes typical quantitative data that can be expected.

Parameter	Method	Typical Result
Labeling Efficiency	Mass Spectrometry (e.g., ESI-MS)	>95% conversion of azide to triazole[1]
Protein Recovery	Desalting Spin Column Purification	>85%[8][9]
Degree of Labeling (DOL)	UV-Vis Spectroscopy	Can be calculated using the absorbance of the protein and the dye.
Purity	SDS-PAGE with In-Gel Fluorescence	A distinct fluorescent band corresponding to the molecular weight of the protein.[10]

Experimental Protocols

Protocol 1: Metabolic Labeling of Proteins with Azide Groups using L-Azidohomoalanine (AHA)

This protocol describes the incorporation of the methionine analog, L-azidohomoalanine (AHA), into newly synthesized proteins in cultured mammalian cells, creating an azide "handle" for subsequent labeling.

Materials:

- Mammalian cells of interest
- Complete cell culture medium
- Methionine-free cell culture medium
- L-Azidohomoalanine (AHA)

- Phosphate-Buffered Saline (PBS)
- Cell lysis buffer (e.g., RIPA buffer) with protease inhibitors

Procedure:

- Culture mammalian cells to the desired confluency in complete medium.
- Aspirate the complete medium and wash the cells twice with warm PBS.
- Replace the medium with pre-warmed methionine-free medium.
- Incubate the cells for 1-2 hours to deplete endogenous methionine.
- Add AHA to the methionine-free medium to a final concentration of 25-50 μM .
- Incubate the cells for 4-24 hours to allow for AHA incorporation into newly synthesized proteins.[1]
- After incubation, wash the cells twice with cold PBS.
- Lyse the cells using a suitable lysis buffer containing protease inhibitors.
- Quantify the protein concentration of the cell lysate. The lysate containing azide-modified proteins is now ready for the click chemistry reaction.

Protocol 2: Labeling of Azide-Modified Proteins with **AF 568 DBCO**

This protocol details the copper-free click chemistry reaction between the azide-modified protein and **AF 568 DBCO**.

Materials:

- Azide-modified protein sample (from Protocol 1 or other methods)
- **AF 568 DBCO**

- Anhydrous Dimethyl Sulfoxide (DMSO)
- Reaction buffer (e.g., PBS, pH 7.2-7.4)

Procedure:

- Prepare **AF 568 DBCO** Stock Solution: Dissolve **AF 568 DBCO** in anhydrous DMSO to prepare a 10 mM stock solution. Store any unused stock solution at -20°C, protected from light and moisture.[8][11]
- Reaction Setup:
 - In a microcentrifuge tube, dilute the azide-modified protein to a concentration of 1-5 mg/mL in the reaction buffer.[8]
 - Add the **AF 568 DBCO** stock solution to the protein solution to achieve a final concentration typically ranging from 10-100 µM. A 10- to 40-fold molar excess of the DBCO reagent over the protein is often a good starting point.[1][9] The optimal molar excess should be determined empirically for each specific protein.
- Incubation: Incubate the reaction mixture for 1-12 hours at room temperature or overnight at 4°C, protected from light.[9][12] The reaction time can be optimized depending on the protein and desired degree of labeling.
- The labeled protein is now ready for purification.

Protocol 3: Purification of Labeled Protein

This protocol describes the removal of unreacted **AF 568 DBCO** using a desalting spin column, a rapid and efficient method for proteins with molecular weights between 20 kDa and 150 kDa. [9] For higher purity, HPLC-based methods can be employed.[8]

Materials:

- Labeled protein reaction mixture
- Desalting spin column (e.g., Zeba™ Spin Desalting Columns)

- Collection tubes
- PBS, pH 7.2

Procedure:

- **Equilibrate the Column:** Prepare the desalting spin column according to the manufacturer's instructions. This typically involves removing the storage buffer and equilibrating the column with PBS.
- **Apply Sample:** Slowly apply the reaction mixture to the center of the resin bed.
- **Centrifuge:** Place the column in a collection tube and centrifuge according to the manufacturer's protocol (e.g., 1,000 x g for 2 minutes).^[9]
- **Collect Labeled Protein:** The purified, labeled protein will be in the eluate in the collection tube. The unreacted **AF 568 DBCO** remains in the column resin.
- **Storage:** Store the purified labeled protein at 4°C, protected from light. For long-term storage, it is recommended to add a cryoprotectant (e.g., glycerol) or stabilizing protein (e.g., BSA) and store in aliquots at -20°C or -80°C.^[13]

Protocol 4: Validation of Labeling by SDS-PAGE and In-Gel Fluorescence

This protocol allows for the confirmation of successful protein labeling.

Materials:

- Labeled and purified protein sample
- Unlabeled protein sample (as a control)
- SDS-PAGE gel and running buffer
- Fluorescence gel imager

Procedure:

- Prepare the labeled and unlabeled protein samples for SDS-PAGE by adding loading buffer.
- Load the samples onto an SDS-PAGE gel and run the electrophoresis.
- After electrophoresis, visualize the gel using a fluorescence imager with settings appropriate for AF 568 (Excitation: ~579 nm, Emission: ~603 nm). A fluorescent band should be observed at the molecular weight of the target protein in the lane with the labeled sample.
- Optionally, the gel can be subsequently stained with a total protein stain (e.g., Coomassie Blue) to visualize all protein bands and confirm that the fluorescence signal co-localizes with the protein of interest.

Experimental and Logical Diagrams

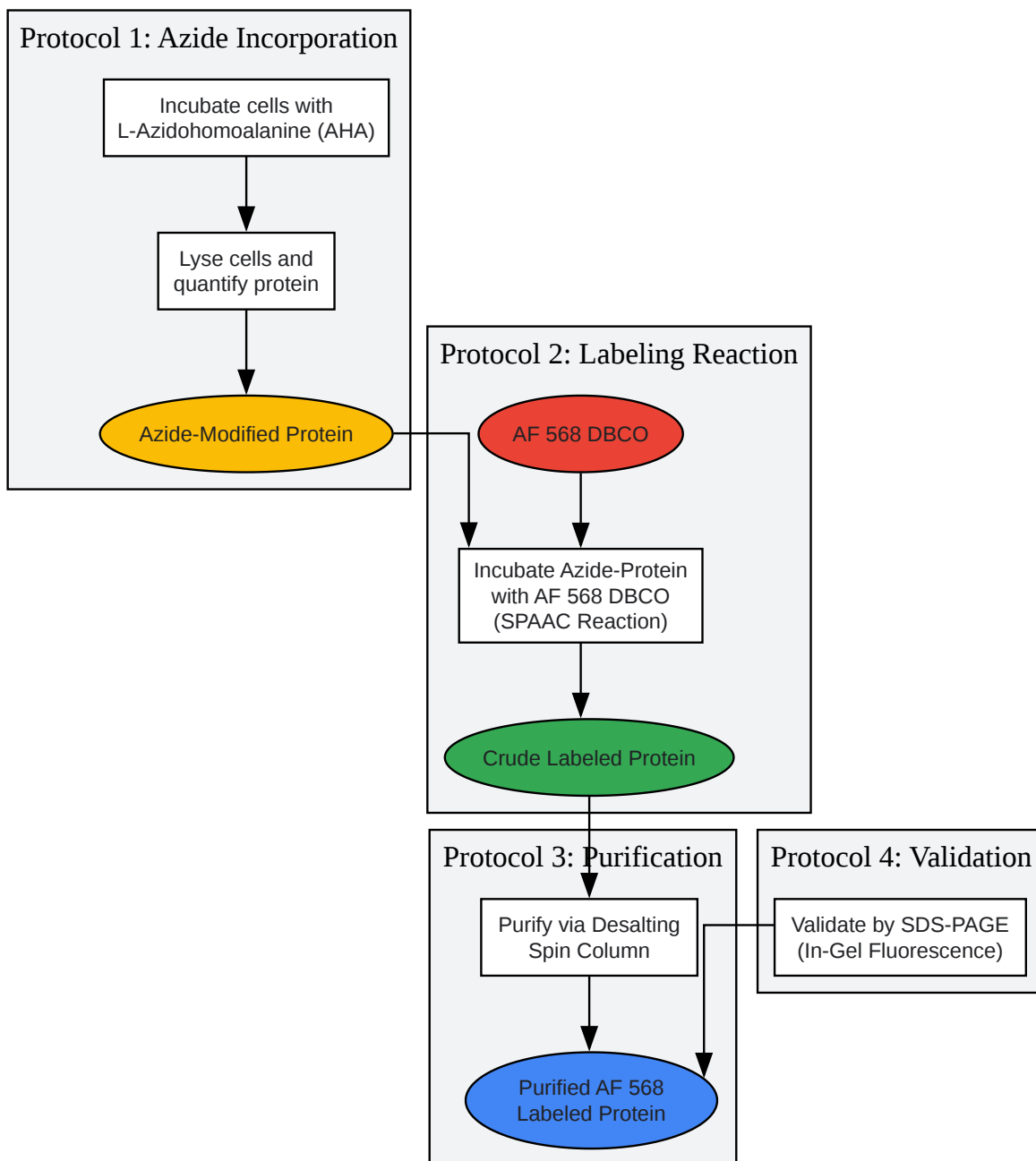

[Click to download full resolution via product page](#)

Caption: Experimental workflow for labeling azide-modified proteins with **AF 568 DBCO**.

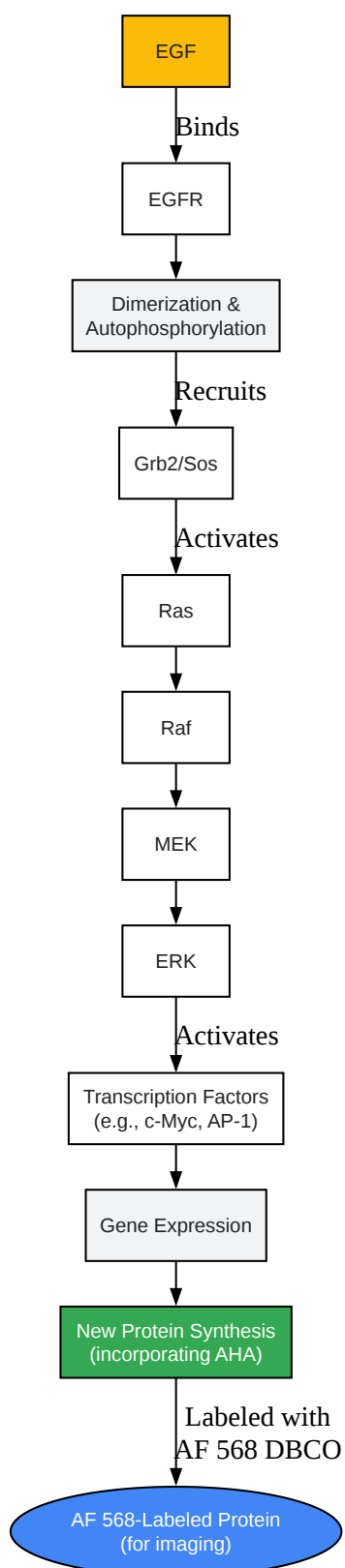

[Click to download full resolution via product page](#)

Caption: Example signaling pathway (EGFR) leading to new protein synthesis and labeling.

Troubleshooting

Problem	Possible Cause	Suggested Solution
No or weak fluorescence	Inefficient azide incorporation.	Optimize AHA concentration and incubation time. Ensure the use of methionine-free medium.[1]
Degraded AF 568 DBCO.	Store the fluorescent probe protected from light and moisture. Use fresh stock solution.[1]	
Insufficient labeling.	Increase the molar excess of AF 568 DBCO or prolong the incubation time.[9]	
High background fluorescence	Incomplete removal of unreacted dye.	Increase the number and duration of wash steps after the labeling reaction. Ensure proper equilibration and use of the desalting column.[1]
Cell toxicity (live-cell imaging)	High concentration of labeling reagents.	Reduce the concentration of AHA and/or AF 568 DBCO. Reduce incubation times.[1]

For research use only. Not for use in diagnostic procedures.

Need Custom Synthesis?

BenchChem offers custom synthesis for rare earth carbides and specific isotopic labeling.

Email: info@benchchem.com or [Request Quote Online](#).

References

- 1. [benchchem.com](https://www.benchchem.com) [benchchem.com]

- [2. broadpharm.com \[broadpharm.com\]](#)
- [3. lumiprobe.com \[lumiprobe.com\]](#)
- [4. vectorlabs.com \[vectorlabs.com\]](#)
- [5. dianabiotech.com \[dianabiotech.com\]](#)
- [6. medchemexpress.com \[medchemexpress.com\]](#)
- [7. AF 568 DBCO | 荧光染料 | MCE \[medchemexpress.cn\]](#)
- [8. benchchem.com \[benchchem.com\]](#)
- [9. documents.thermofisher.com \[documents.thermofisher.com\]](#)
- [10. benchchem.com \[benchchem.com\]](#)
- [11. help.lumiprobe.com \[help.lumiprobe.com\]](#)
- [12. docs.aatbio.com \[docs.aatbio.com\]](#)
- [13. ulab360.com \[ulab360.com\]](#)
- To cite this document: BenchChem. [Application Notes and Protocols: AF 568 DBCO Protein Labeling]. BenchChem, [2026]. [Online PDF]. Available at: [\[https://www.benchchem.com/product/b12363973/docs#application-notes-and-protocols-af-568-dbc0-protein-labeling\]](https://www.benchchem.com/product/b12363973/docs#application-notes-and-protocols-af-568-dbc0-protein-labeling)

Disclaimer & Data Validity:

The information provided in this document is for Research Use Only (RUO) and is strictly not intended for diagnostic or therapeutic procedures. While BenchChem strives to provide accurate protocols, we make no warranties, express or implied, regarding the fitness of this product for every specific experimental setup.

Technical Support: The protocols provided are for reference purposes. Unsure if this reagent suits your experiment?

Need Industrial/Bulk Grade? [Request Custom Synthesis Quote](#)

BenchChem

Our mission is to be the trusted global source of essential and advanced chemicals, empowering scientists and researchers to drive progress in science and industry.

Contact

Address: 3281 E Guasti Rd

Ontario, CA 91761, United States

Phone: (601) 213-4426

Email: info@benchchem.com

[Contact our Ph.D. Support Team for a compatibility check](#)