

AF 568 DBCO: A Technical Guide for Advanced Bioconjugation

Author: BenchChem Technical Support Team. **Date:** April 2026

Compound of Interest

Compound Name: AF 568 DBCO

Cat. No.: B12363973

[Get Quote](#)

For Researchers, Scientists, and Drug Development Professionals

This in-depth technical guide provides a comprehensive overview of **AF 568 DBCO**, a fluorescent dye and bioorthogonal chemical tool widely utilized in biological research and drug development. This document details its chemical structure, key characteristics, and practical applications, with a focus on enabling researchers to effectively employ this reagent in their experimental workflows.

Core Characteristics of AF 568 DBCO

AF 568 DBCO is a molecule that combines the bright and photostable AF 568 fluorophore with a dibenzocyclooctyne (DBCO) group.^[1] The AF 568 dye is structurally identical to Alexa Fluor 568, a popular orange-fluorescent dye known for its high quantum yield and photostability.^{[2][3]} The DBCO moiety is one of the most reactive cycloalkynes for copper-free click chemistry, enabling covalent labeling of azide-containing biomolecules within living cells or whole organisms without the need for a cytotoxic copper catalyst.^{[2][3][4]} This biocompatible reaction, known as Strain-Promoted Alkyne-Azide Cycloaddition (SPAAC), is highly efficient and forms a stable triazole linkage.^{[3][5]}

The hydrophilic nature of the AF 568 dye makes it an excellent choice for labeling sensitive proteins, while its pH resistance ensures stable fluorescence across a wide range of experimental conditions.[2][6] These properties, combined with the bioorthogonal reactivity of the DBCO group, make **AF 568 DBCO** a powerful tool for a variety of applications, including confocal microscopy, super-resolution microscopy, and flow cytometry.[2]

Chemical Structure

The chemical structure of **AF 568 DBCO** consists of the AF 568 fluorophore core linked to a DBCO moiety.

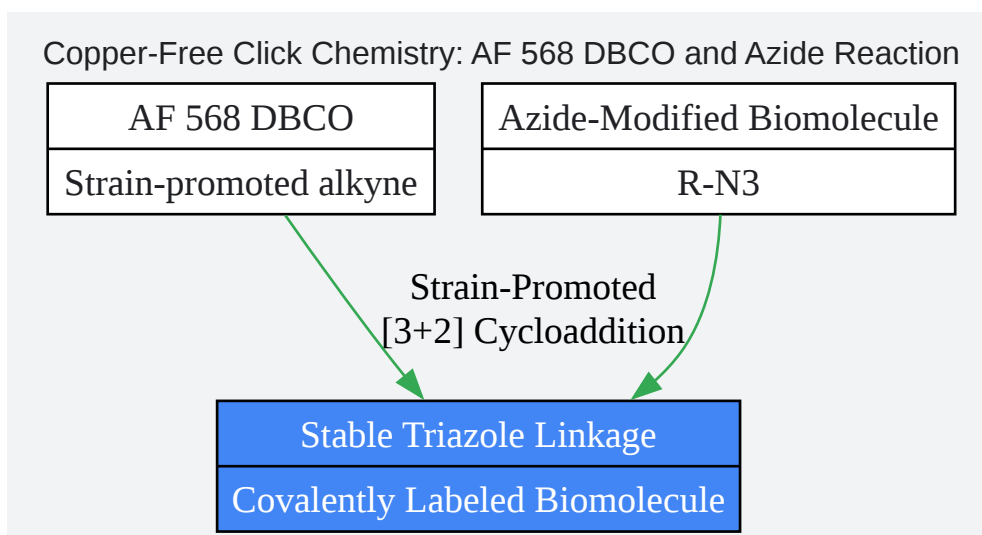
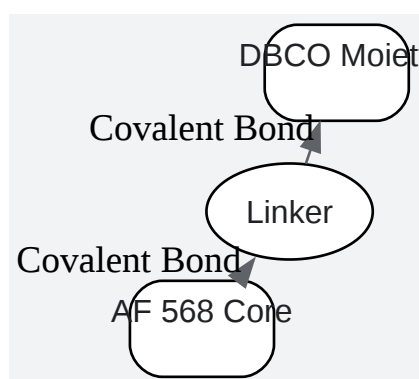

Experimental Workflow: Antibody Labeling with AF 568 DBCO

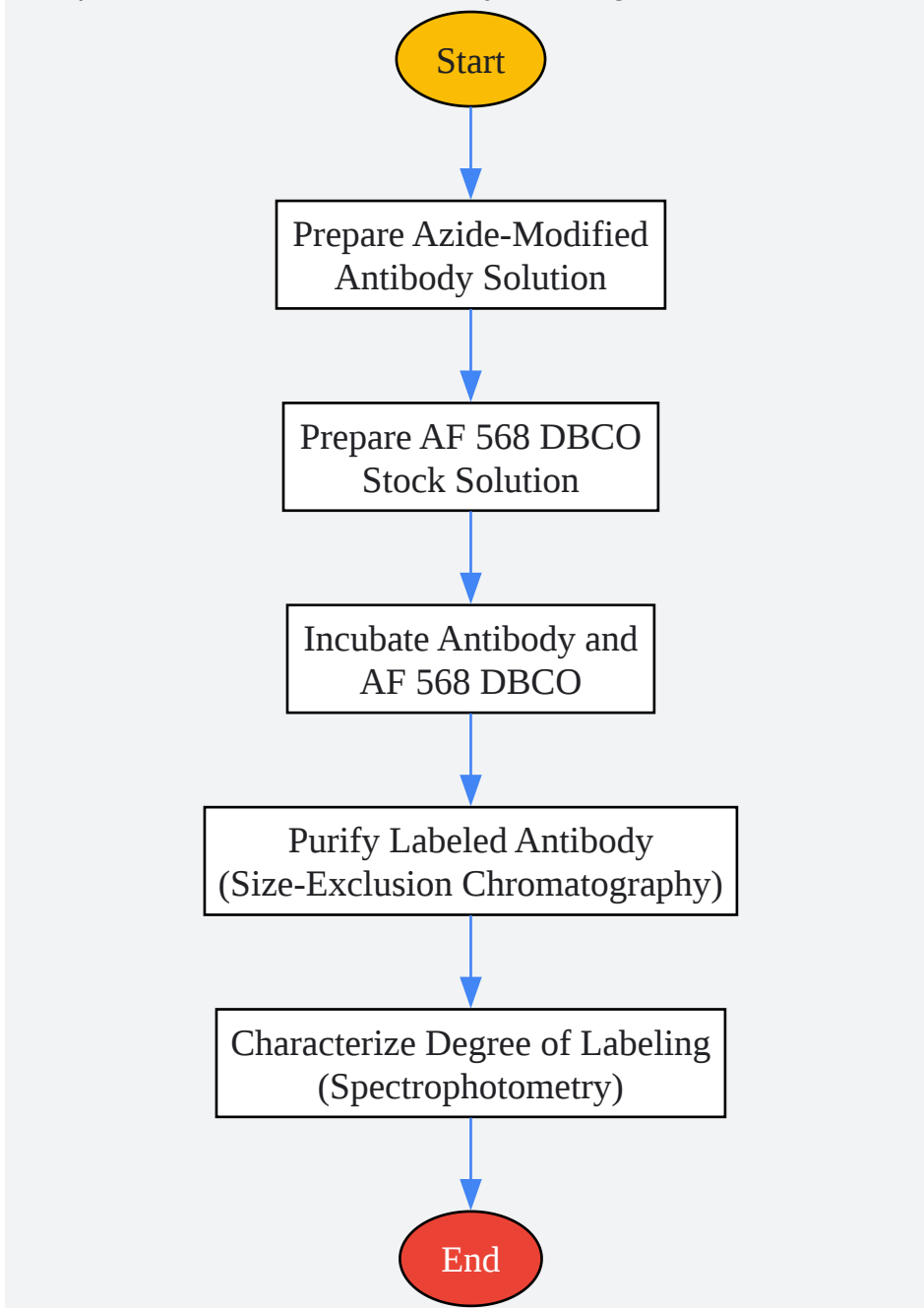

[Click to download full resolution via product page](#)

Need Custom Synthesis?

BenchChem offers custom synthesis for rare earth carbides and specific isotopic labeling.

Email: info@benchchem.com or [Request Quote Online](#).

References

- [1. lumiprobe.com \[lumiprobe.com\]](#)
- [2. dianabiotech.com \[dianabiotech.com\]](#)
- [3. vectorlabs.com \[vectorlabs.com\]](#)
- [4. lumiprobe.com \[lumiprobe.com\]](#)
- [5. docs.aatbio.com \[docs.aatbio.com\]](#)
- [6. lumiprobe.com \[lumiprobe.com\]](#)
- To cite this document: BenchChem. [AF 568 DBCO: A Technical Guide for Advanced Bioconjugation]. BenchChem, [2026]. [Online PDF]. Available at: [\[https://www.benchchem.com/product/b12363973/docs#af-568-dbc0-a-technical-guide-for-advanced-bioconjugation\]](https://www.benchchem.com/product/b12363973/docs#af-568-dbc0-a-technical-guide-for-advanced-bioconjugation)

Disclaimer & Data Validity:

The information provided in this document is for Research Use Only (RUO) and is strictly not intended for diagnostic or therapeutic procedures. While BenchChem strives to provide accurate protocols, we make no warranties, express or implied, regarding the fitness of this product for every specific experimental setup.

Technical Support: The protocols provided are for reference purposes. Unsure if this reagent suits your experiment?

Need Industrial/Bulk Grade? [Request Custom Synthesis Quote](#)

BenchChem

Our mission is to be the trusted global source of essential and advanced chemicals, empowering scientists and researchers to drive progress in science and industry.

Contact

Address: 3281 E Guasti Rd
Ontario, CA 91761, United States
Phone: (601) 213-4426
Email: info@benchchem.com

Contact our Ph.D. Support Team for a compatibility check