

Technical Support Center: Optimizing LSN3353871 for Maximal Lp(a) Inhibition

Author: BenchChem Technical Support Team. **Date:** April 2026

Compound of Interest

Compound Name: LSN3353871

Cat. No.: B12362211

[Get Quote](#)

Welcome to the technical support center for researchers utilizing **LSN3353871** to investigate the inhibition of Lipoprotein(a) [Lp(a)]. This resource provides troubleshooting guides and frequently asked questions (FAQs) to facilitate the effective use of this small molecule inhibitor in your experiments.

Frequently Asked Questions (FAQs)

Q1: What is the mechanism of action of **LSN3353871**?

A1: **LSN3353871** is a small molecule inhibitor that disrupts the formation of Lp(a). It functions by binding to the Kringle IV (KIV) domains 7 and 8 of apolipoprotein(a) [apo(a)], which prevents the initial non-covalent interaction between apo(a) and apolipoprotein B-100 (apoB-100) on low-density lipoprotein (LDL) particles. This inhibition of the first step of Lp(a) assembly ultimately leads to a reduction in circulating Lp(a) levels.^{[1][2][3][4][5]}

Q2: What is the relationship between **LSN3353871** and muvalaplin?

A2: **LSN3353871** is a prototype compound that demonstrated the feasibility of inhibiting Lp(a) formation with a small molecule.^[3] Muvalaplin (formerly LY3473329) is a more potent, multivalent successor to **LSN3353871**.^{[3][5]} While structurally related, muvalaplin has been

further optimized for clinical development. The experimental principles and troubleshooting advice provided here for **LSN3353871** are generally applicable to muvalaplin and other similar small molecule inhibitors of Lp(a) formation.

Q3: What are the recommended storage and handling conditions for **LSN3353871**?

A3: For optimal stability, **LSN3353871** should be stored as a solid at 4°C, sealed, and away from moisture. In solvent, stock solutions should be stored at -80°C for up to 6 months or at -20°C for up to 1 month. It is advisable to aliquot stock solutions to avoid repeated freeze-thaw cycles.

Q4: How do I prepare **LSN3353871** for in vitro and in vivo experiments?

A4: **LSN3353871** is soluble in DMSO. For in vitro experiments, prepare a high-concentration stock solution in DMSO (e.g., 10 mM) and then dilute it to the final working concentration in your cell culture medium. Ensure the final DMSO concentration in your assay is low (typically \leq 0.1%) to avoid solvent-induced toxicity. For in vivo studies in mice, **LSN3353871** can be administered via oral gavage. The compound should be formulated in a suitable vehicle, ensuring a homogenous and stable suspension.

Q5: What are the potential off-target effects of **LSN3353871**, and how can I control for them?

A5: A potential off-target for molecules binding to apo(a) Kringle domains is plasminogen, due to structural homology.^{[1][3][4]} While studies on the more advanced compound, muvalaplin, suggest species-specific differences in plasminogen interaction, with no significant effects observed in humans, it is a crucial parameter to consider.^[3] To control for off-target effects, it is recommended to:

- Include a structurally related but inactive control compound in your experiments, if available.
- Perform a rescue experiment by overexpressing the target protein to see if the phenotype is reversed.
- Use a secondary, structurally distinct inhibitor of the same target to confirm that the observed effects are consistent.
- For in vivo studies, monitor for any unexpected adverse effects.

Troubleshooting Guides

In Vitro Experiments

Issue	Possible Cause(s)	Suggested Solution(s)
Low or no Lp(a) inhibition observed	1. Incorrect compound concentration: Calculation error or degradation of the compound. 2. Suboptimal assay conditions: Incorrect incubation times or reagent concentrations. 3. Cell health issues: Cells are not healthy or are at a high passage number.	1. Verify the concentration of your LSN3353871 stock solution. Prepare fresh dilutions for each experiment. 2. Optimize incubation times and reagent concentrations. Refer to the detailed protocol below. 3. Ensure you are using healthy, low-passage cells. Perform a cell viability assay to confirm the non-toxic concentration range of LSN3353871.
High variability between replicates	1. Inconsistent cell seeding: Uneven cell distribution in the plate. 2. Pipetting errors: Inaccurate dispensing of compound or reagents. 3. Compound precipitation: The compound may be precipitating out of solution at the working concentration.	1. Ensure a homogenous cell suspension before seeding. Use a multichannel pipette for consistency. 2. Calibrate your pipettes regularly. Use fresh tips for each addition. 3. Visually inspect the working solution for any precipitate. If necessary, sonicate briefly or prepare fresh dilutions.
Unexpected changes in cell morphology or viability	1. Cytotoxicity of LSN3353871: The concentration used may be too high. 2. Solvent toxicity: The final concentration of DMSO may be toxic to the cells. 3. Off-target effects: The compound may be interacting with other cellular pathways.	1. Perform a dose-response curve to determine the IC50 and a separate cell viability assay (e.g., MTT) to determine the cytotoxic concentration. 2. Ensure the final DMSO concentration is below the toxic threshold for your cell line (typically $\leq 0.1\%$). Include a vehicle control (media with the same concentration of DMSO without the inhibitor). 3.

Investigate potential off-target effects as described in the FAQs.

Lp(a) Measurement (ELISA)

Issue	Possible Cause(s)	Suggested Solution(s)
High background	<p>1. Insufficient washing: Residual reagents remaining in the wells. 2. Antibody concentration too high: Non-specific binding of the detection antibody. 3. Blocking step ineffective: Incomplete blocking of non-specific binding sites.</p>	<p>1. Increase the number of wash steps and ensure complete aspiration of wash buffer between steps. 2. Titrate the detection antibody to the optimal concentration. 3. Use a different blocking buffer or increase the blocking incubation time.</p>
No or weak signal	<p>1. Reagent degradation: Improper storage of antibodies or substrate. 2. Incorrect reagent preparation: Errors in dilution of antibodies or standards. 3. Insufficient incubation times: Incubation times are too short for optimal binding.</p>	<p>1. Check the expiration dates and storage conditions of all reagents. 2. Double-check all calculations and dilutions. Prepare fresh reagents. 3. Increase the incubation times for antibody and substrate steps.</p>
High coefficient of variation (CV) between replicates	<p>1. Inconsistent pipetting: Variation in the volume of samples, standards, or reagents. 2. Plate not washed uniformly: Inconsistent washing across the plate. 3. Temperature gradients: Uneven temperature across the plate during incubation.</p>	<p>1. Use a calibrated multichannel pipette. Change tips for each sample and standard. 2. Ensure all wells are filled and aspirated completely during washing. 3. Allow all reagents to come to room temperature before use. Incubate the plate in a temperature-controlled environment.</p>
Results affected by apo(a) isoform size	<p>1. Assay design: The ELISA kit may be sensitive to the size of the apo(a) isoform.</p>	<p>1. Use an isoform-insensitive Lp(a) assay. These assays typically use a capture antibody that recognizes a unique epitope on apo(a) that</p>

is not part of the variable
Kringle IV type 2 repeats.[6]

Data Presentation

Table 1: In Vitro Lp(a) Inhibition with **LSN3353871**

Parameter	Value
Binding Affinity (Kd)	
KIV8	756 nM
KIV7-8	605 nM
KIV5-8	423 nM
In Vitro Lp(a) Assembly Inhibition (IC50)	1.69 μ M

Data from in vitro binding and assembly assays.[3]

Table 2: In Vivo Lp(a) Reduction with **LSN3353871**

Animal Model	Dose	Lp(a) Reduction
Human Lp(a) Transgenic Mice	14 mg/kg twice daily (ED50)	Up to 78%
Cynomolgus Monkeys	20 mg/kg twice daily	Up to 40%

Data from preclinical in vivo studies.[3]

Experimental Protocols

In Vitro Lp(a) Formation Inhibition Assay

This protocol is adapted from established methods for assessing the in vitro assembly of Lp(a).
[2][7]

Materials:

- Purified human LDL
- Recombinant human apolipoprotein(a) [apo(a)]
- **LSN3353871** stock solution (10 mM in DMSO)
- Assay buffer (e.g., PBS with calcium and magnesium)
- 96-well microplate
- Lp(a) ELISA kit (isoform-insensitive)

Procedure:

- Prepare serial dilutions of **LSN3353871** in the assay buffer. Include a vehicle control (assay buffer with the same final concentration of DMSO).
- Add a fixed concentration of apo(a) to each well of the 96-well plate.
- Add the serially diluted **LSN3353871** or vehicle control to the respective wells.
- Incubate for 30 minutes at 37°C to allow the inhibitor to bind to apo(a).
- Add a fixed concentration of LDL to each well to initiate the Lp(a) assembly reaction.
- Incubate for 18 hours at 37°C.
- Quantify the amount of newly formed Lp(a) in each well using an isoform-insensitive Lp(a) ELISA kit according to the manufacturer's instructions.
- Calculate the percent inhibition for each concentration of **LSN3353871** relative to the vehicle control.
- Plot the percent inhibition against the log of the inhibitor concentration to determine the IC50 value.

In Vivo Lp(a) Inhibition in Human Lp(a) Transgenic Mice

This protocol provides a general framework for in vivo studies. Specifics may need to be optimized based on the transgenic mouse model used.[8][9]

Materials:

- Human Lp(a) transgenic mice
- **LSN3353871**
- Vehicle for oral gavage (e.g., 0.5% methylcellulose)
- Blood collection supplies (e.g., capillary tubes, microcentrifuge tubes)
- Lp(a) ELISA kit (isoform-insensitive)

Procedure:

- Acclimatize the mice to the housing conditions for at least one week.
- Randomly assign mice to different treatment groups (vehicle control and various doses of **LSN3353871**).
- Collect baseline blood samples from all mice via tail vein or retro-orbital sinus.
- Prepare the dosing solutions of **LSN3353871** in the vehicle. Ensure a homogenous suspension.
- Administer the assigned treatment to each mouse daily via oral gavage for the duration of the study (e.g., 14 days).
- Monitor the health and body weight of the mice regularly.
- At the end of the treatment period, collect final blood samples.
- Separate plasma from the blood samples by centrifugation.
- Measure the Lp(a) concentration in the plasma samples using an isoform-insensitive Lp(a) ELISA kit.

- Calculate the percentage change in Lp(a) levels from baseline for each mouse.
- Compare the Lp(a) reduction in the **LSN3353871**-treated groups to the vehicle control group to determine the in vivo efficacy.

Mandatory Visualizations

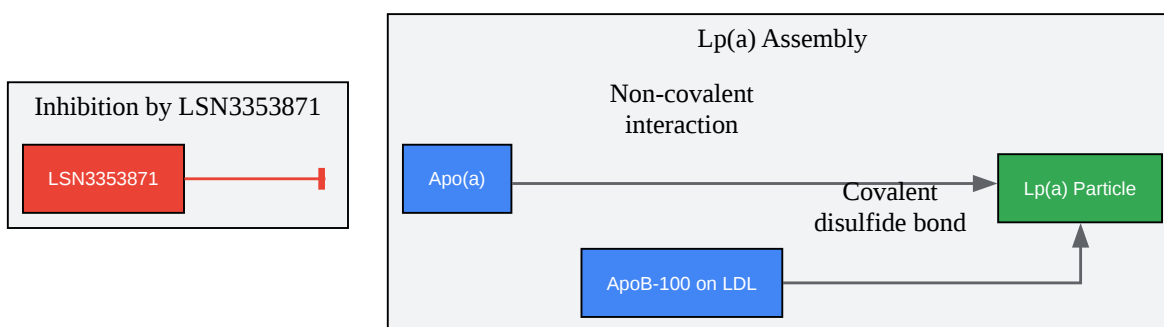

[Click to download full resolution via product page](#)

Caption: Mechanism of Lp(a) formation and inhibition by **LSN3353871**.

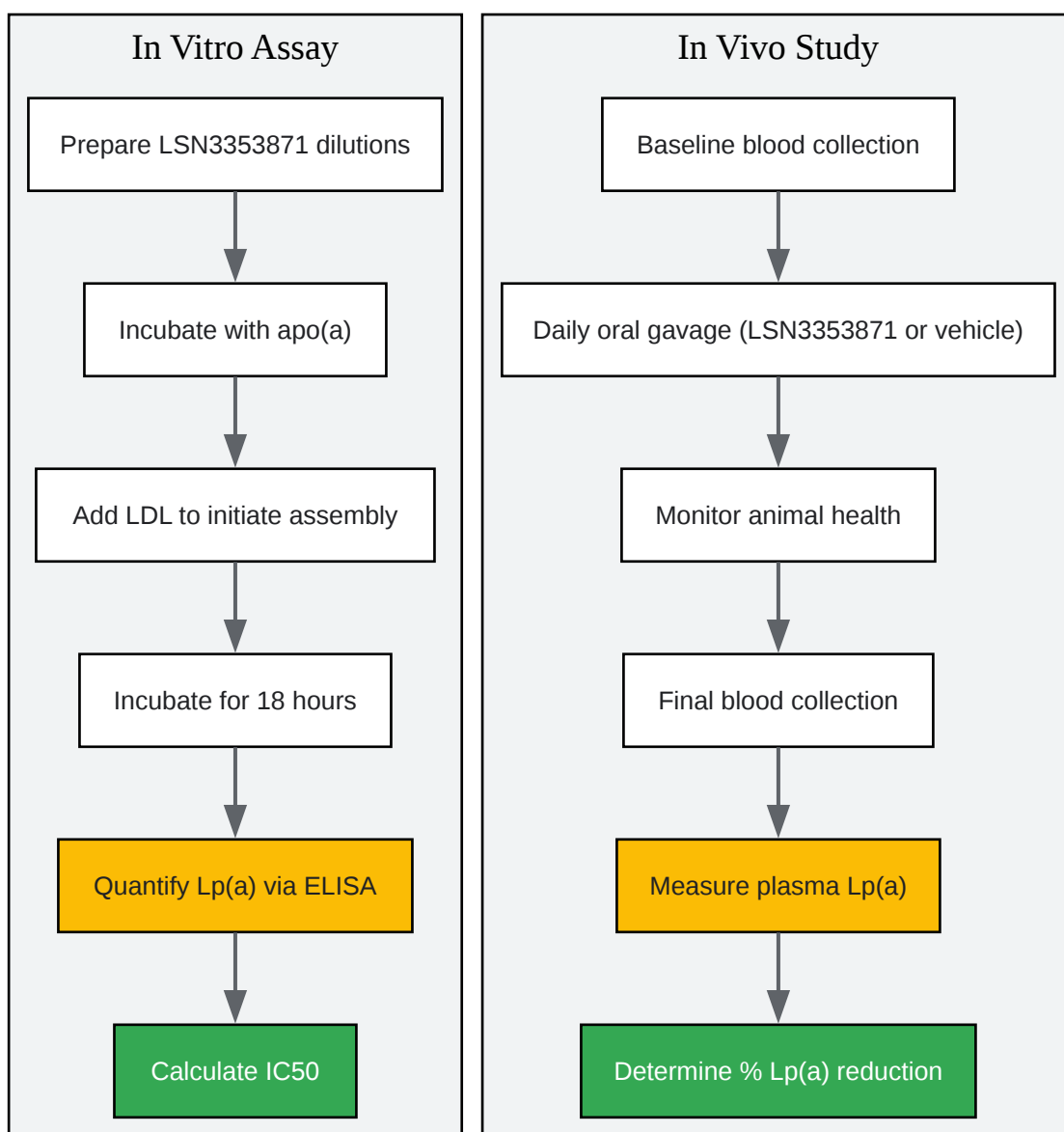

[Click to download full resolution via product page](#)

Caption: General experimental workflows for in vitro and in vivo studies.

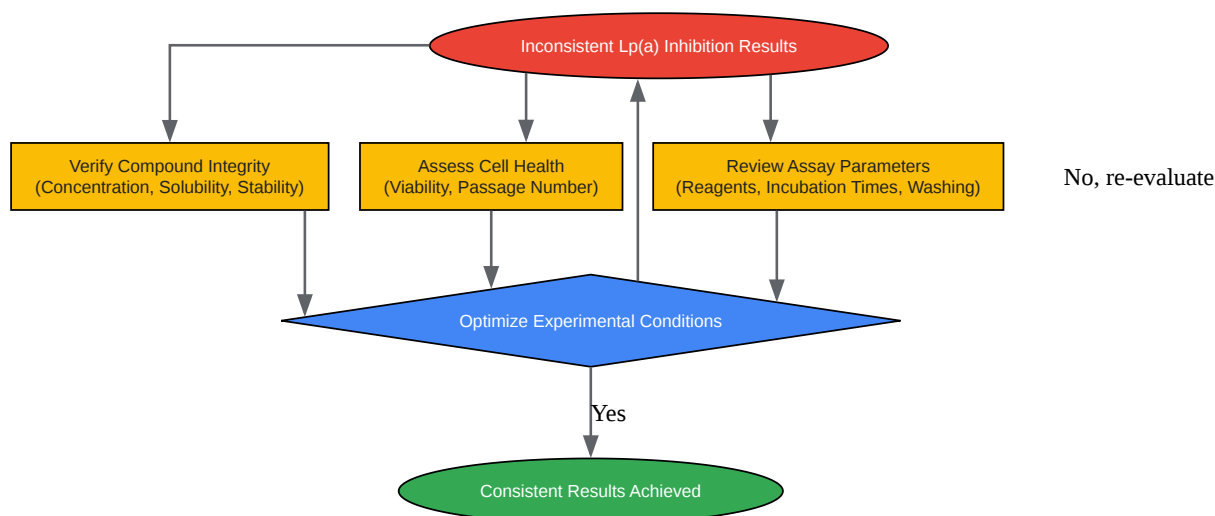

[Click to download full resolution via product page](#)

Need Custom Synthesis?

BenchChem offers custom synthesis for rare earth carbides and specific isotopic labeling.

Email: info@benchchem.com or [Request Quote Online](#).

References

- [1. researchgate.net \[researchgate.net\]](https://www.researchgate.net)
- [2. Inhibitors for the in vitro assembly of Lp\(a\) - PubMed \[pubmed.ncbi.nlm.nih.gov\]](https://pubmed.ncbi.nlm.nih.gov)
- [3. Discovery of potent small-molecule inhibitors of lipoprotein\(a\) formation - PMC \[pmc.ncbi.nlm.nih.gov\]](https://pubmed.ncbi.nlm.nih.gov)
- [4. Discovery of potent small-molecule inhibitors of lipoprotein\(a\) formation - PubMed \[pubmed.ncbi.nlm.nih.gov\]](https://pubmed.ncbi.nlm.nih.gov)
- [5. Oral agents for lowering lipoprotein\(a\) - PubMed \[pubmed.ncbi.nlm.nih.gov\]](https://pubmed.ncbi.nlm.nih.gov)
- [6. The ins and outs of lipoprotein\(a\) assay methods - PMC \[pmc.ncbi.nlm.nih.gov\]](https://pubmed.ncbi.nlm.nih.gov)

- [7. ahajournals.org \[ahajournals.org\]](https://ahajournals.org)
- [8. LPA disruption with AAV-CRISPR potently lowers plasma apo\(a\) in transgenic mouse model: A proof-of-concept study - PMC \[pmc.ncbi.nlm.nih.gov\]](https://pubmed.ncbi.nlm.nih.gov/3353871/)
- [9. High-level lipoprotein \[a\] expression in transgenic mice: evidence for oxidized phospholipids in lipoprotein \[a\] but not in low density lipoproteins - PubMed \[pubmed.ncbi.nlm.nih.gov\]](https://pubmed.ncbi.nlm.nih.gov/3353871/)
- To cite this document: BenchChem. [Technical Support Center: Optimizing LSN3353871 for Maximal Lp(a) Inhibition]. BenchChem, [2026]. [Online PDF]. Available at: [\[https://www.benchchem.com/product/b12362211/docs#technical-support-center-optimizing-lsn3353871-for-maximal-lp-a-inhibition\]](https://www.benchchem.com/product/b12362211/docs#technical-support-center-optimizing-lsn3353871-for-maximal-lp-a-inhibition)

Disclaimer & Data Validity:

The information provided in this document is for Research Use Only (RUO) and is strictly not intended for diagnostic or therapeutic procedures. While BenchChem strives to provide accurate protocols, we make no warranties, express or implied, regarding the fitness of this product for every specific experimental setup.

Technical Support: The protocols provided are for reference purposes. Unsure if this reagent suits your experiment?

Need Industrial/Bulk Grade? [Request Custom Synthesis Quote](#)

BenchChem

Our mission is to be the trusted global source of essential and advanced chemicals, empowering scientists and researchers to drive progress in science and industry.

Contact

Address: 3281 E Guasti Rd
Ontario, CA 91761, United States
Phone: (601) 213-4426
Email: info@benchchem.com

Contact our Ph.D. Support Team for a compatibility check